

APPROVAL SHEET

WLSN104D Series Unshielded SMD Power Inductors

*Contents in this sheet are subject to change without prior notice.

Features

1. Unshielded power inductor.
2. Wide inductance range.

Applications

1. Inductor in DC/DC converter.
2. Use in STB 、 PDA 、 Notebook.

Shape and Dimension

Unit: mm

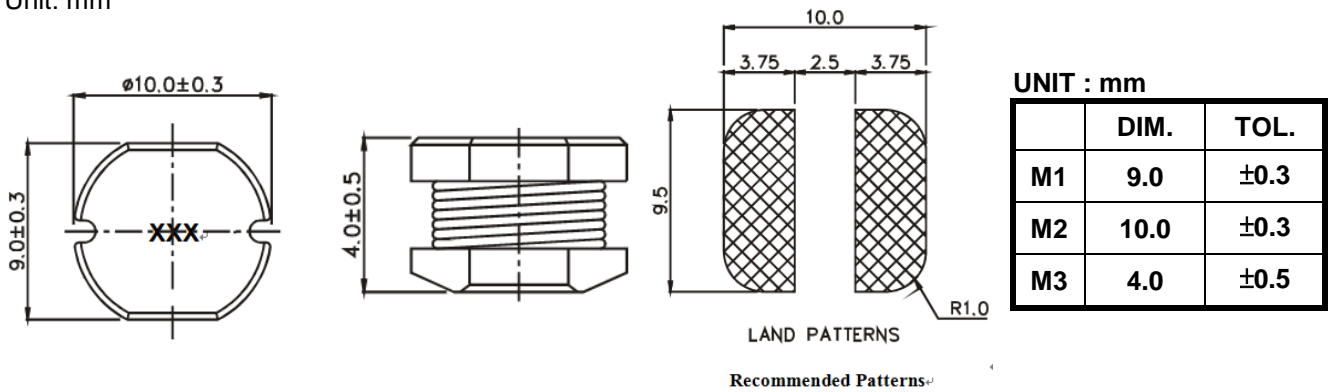

Ordering Information

WL	SN	104D	Z0	M	100	L	B
Product Code WL: Inductor	Series Unshielded SMD Power Inductors	Dimensions 10.0 * 9.0 * 4 mm	Series extension Z0:STD	Tolerance K: ± 10% M: ± 20%	Value 100 = 10.0uH 101 = 100uH 102 = 1000uH	Packing Code P=13" Reeled (Embossed tape)	B:STD

Electrical Characteristics

WLSN104D Series	Marking	Inductance (uH)	Inductance Tolerance	Test Freq (KHz)	DCR MAX. (Ω)	Rated Current (A)
WLSN104DZ0□100LB	100	10	± 10%, ± 20%	100	0.053	2.38
WLSN104DZ0□120LB	120	12	± 10%, ± 20%	100	0.061	2.13
WLSN104DZ0□150LB	150	15	± 10%, ± 20%	100	0.070	1.87
WLSN104DZ0□180LB	180	18	± 10%, ± 20%	100	0.081	1.73
WLSN104DZ0□220LB	220	22	± 10%, ± 20%	100	0.088	1.60
WLSN104DZ0□270LB	270	27	± 10%, ± 20%	100	0.100	1.44
WLSN104DZ0□330LB	330	33	± 10%, ± 20%	100	0.120	1.26
WLSN104DZ0□390LB	390	39	± 10%, ± 20%	100	0.151	1.20
WLSN104DZ0□470LB	470	47	± 10%, ± 20%	100	0.170	1.10
WLSN104DZ0□560LB	560	56	± 10%, ± 20%	100	0.199	1.01
WLSN104DZ0□680LB	680	68	± 10%, ± 20%	100	0.223	0.91
WLSN104DZ0□820LB	820	82	± 10%, ± 20%	100	0.252	0.85
WLSN104DZ0□101LB	101	100	± 10%, ± 20%	10	0.344	0.74
WLSN104DZ0□121LB	121	120	± 10%, ± 20%	10	0.396	0.69
WLSN104DZ0□151LB	151	150	± 10%, ± 20%	10	0.544	0.61
WLSN104DZ0□181LB	181	180	± 10%, ± 20%	10	0.621	0.56
WLSN104DZ0□221LB	221	220	± 10%, ± 20%	10	0.721	0.53
WLSN104DZ0□271LB	271	270	± 10%, ± 20%	10	0.949	0.45
WLSN104DZ0□331LB	331	330	± 10%, ± 20%	10	1.100	0.42
WLSN104DZ0□391LB	391	390	± 10%, ± 20%	10	1.245	0.38
WLSN104DZ0□471LB	471	470	± 10%, ± 20%	10	1.526	0.35
WLSN104DZ0□561LB	561	560	± 10%, ± 20%	10	1.904	0.32
WLSN104DZ0□102LB	102	1000	± 10%, ± 20%	1	3.800	0.16

a. Tolerance : M : ±20%, K : ±10%

b. Operating Temperature Range : -25°C to +105°C (Including self-generated heat).

.Inductance measured using the HP4284A; Chroma 3302+1320

.DCR measured using the 16502 milli-ohm meter.

.Inductance drops no more than 10 % of initial value at rated current , temperature rises $\Delta t < 40^{\circ}\text{C}$

.Storage Temperature Range: -40°C to +85°C

*MSL : LEVEL 1

TYPICAL RoHS REFLOW PROFILE

Typical RoHS Reflow Profile

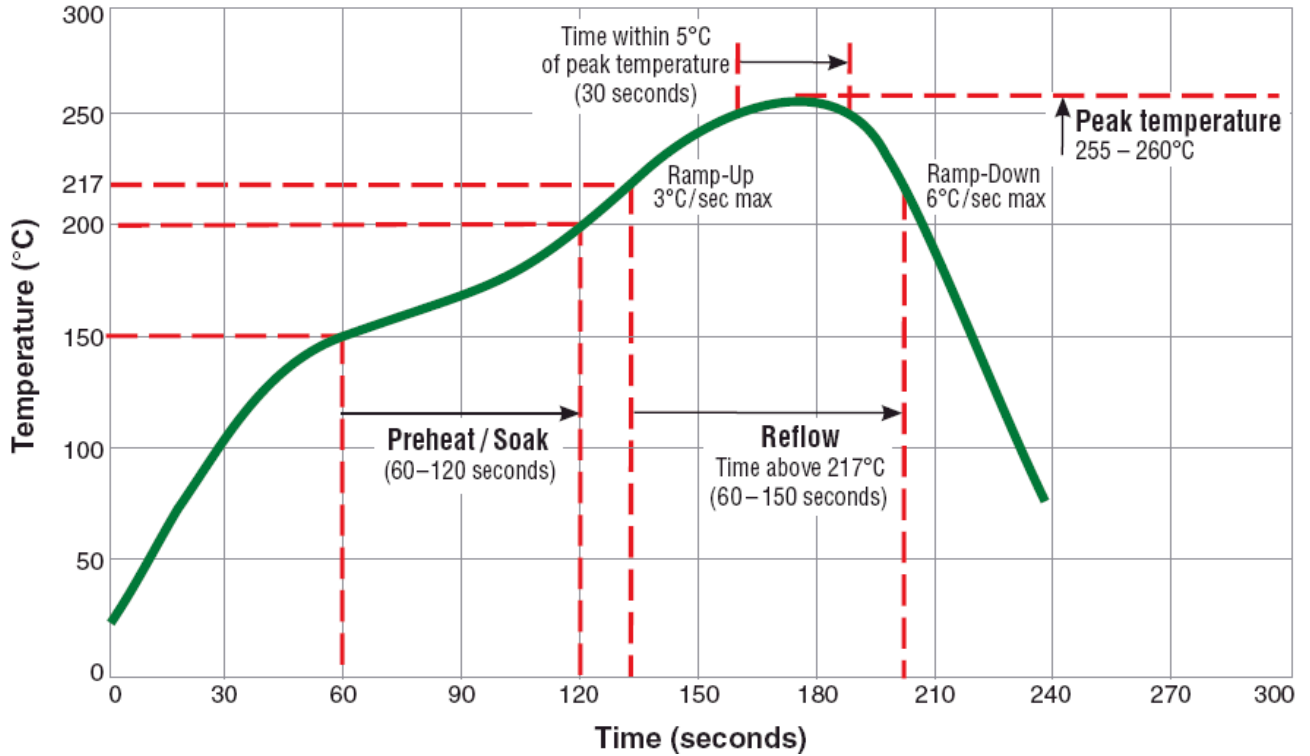

RELIABILITY PERFORMANCE

No.	Item	Test condition	Requirements
1	Humidity Test	+40°C±2°C, humidity of 90% ± 5% (total 96 hours).	MIL-STD-202G Method 103B Test Condition B
2	High Temperature Test	1.Temperature: +125°C±2°C 2.Test time: 48±2hrs	IEC 68-2 Test Condition B
3	Low Temperature Test	1.Temperature: -40°C±2°C 2.Test time: 48±2hrs	IEC 68-2 Test Condition A
4	Thermal Shock	+125°C±5°C (30 minutes) ~ -40 ± 5°C (30 minutes), temperature switch time: 5 minutes (total 50 cycles).	MIL-STD-202G Method 107G Test Condition B-2
5	Life Test	+70°C±5°C (300 Hours)	MIL-STD-202G Method 108A Test Condition D
6	Vibration Test	10-55-10HZ, amplitude: 1.5mm, direction: X, Y, Z axes, each axis 2 hours (total 6 hours).	MIL-STD-202G Method 201A
7	Solder Heat Resistance Test	Reflow: Keep 250 ±5°C, 30 ±5Sec in air, Temperature ramp:+1~4°C/sec; Above 183°C, must keep 90 s - 120 s.	MIL-STD-202G Method 210F Test Condition (Reflow)
8	Solder Ability Test	Soak in 245 °C solder pot of 3Sec, PAD must have 95% above coverage.	J-STD-003B
9	Terminal Push Strength Test	No special requirements: 5N thrust to maintain 10 Sec.	JIS C5321:1997

Tape & Reel Packaging Dimensions:

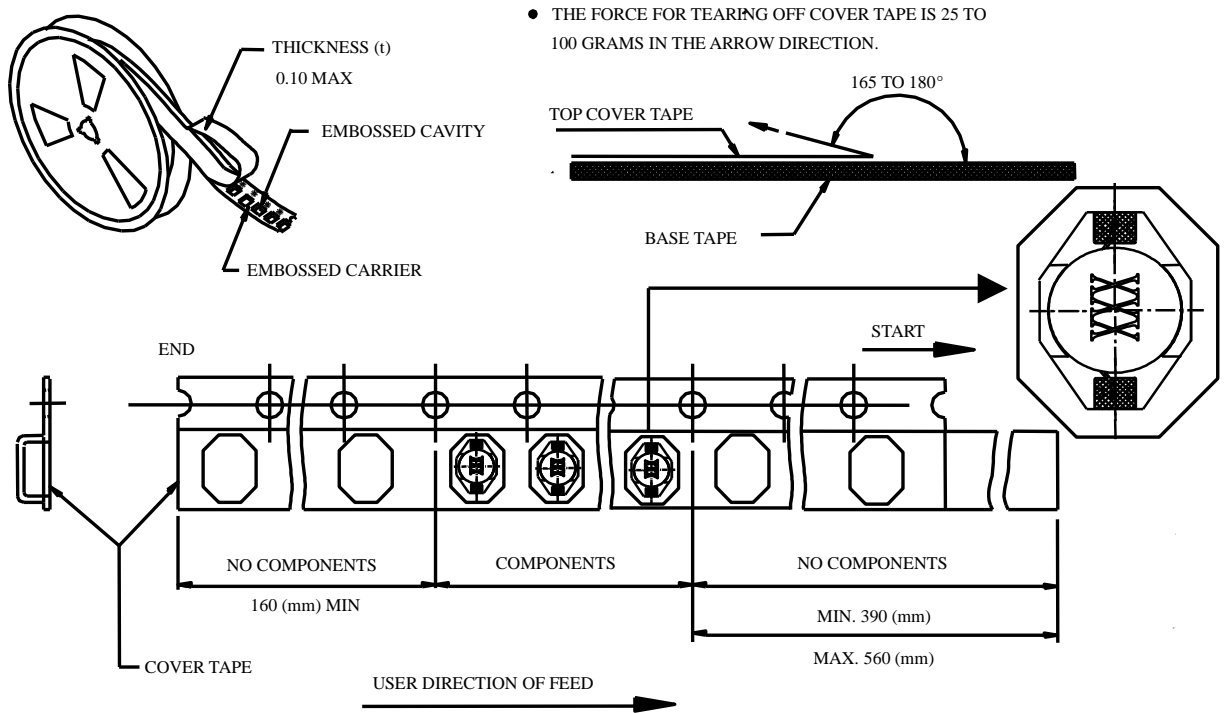

• THE FORCE FOR TEARING OFF COVER TAPE IS 25 TO 100 GRAMS IN THE ARROW DIRECTION.

■ CARRIER TAPE REELS (mm)

MATERIAL: PLASTIC

■ DIMENSIONS OF CARRIER TAPE (mm)

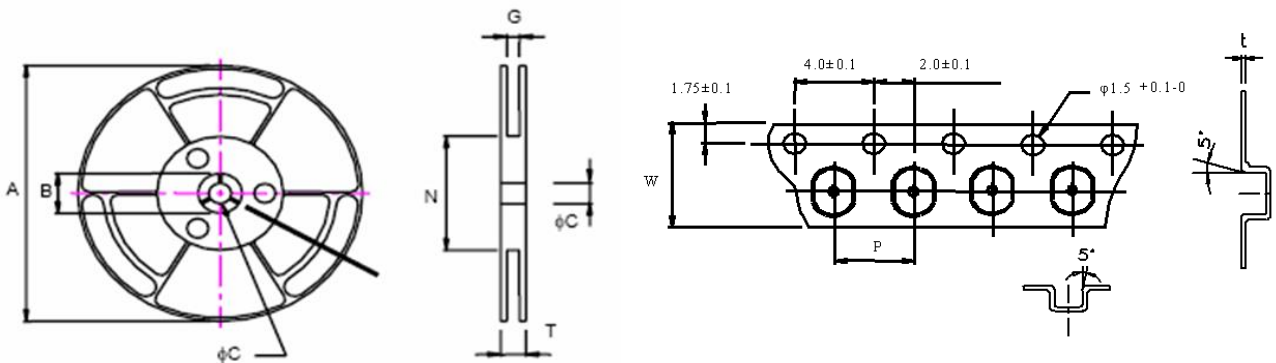

UNIT : mm

	A	B	C	G	N	P	T	W	t
DIM.	360	21.0	13.0	24.4	100.0	16.0	30.4	24.0	0.3
TOL.	MAX.	±0.8	±0.5	±2.0	MIN.	±0.1	MAX.	±0.3	±0.05

Quantity per reel : 1.2K pcs