

APPROVAL SHEET

WLSN054D Series SMD Unshielded Power Inductors

*Contents in this sheet are subject to change without prior notice.

Features

1. Unshielded power inductor.
2. Wide inductance range.

Applications

1. Inductor in DC/DC converter.
2. Use in STB、PDA、Notebook.

Shape and Dimension

Unit: mm

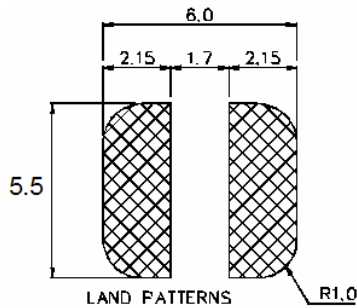
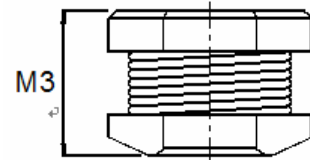
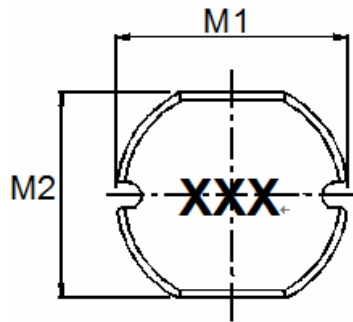

	DIM.	TOL.
M1	5.8	±0.3
M2	5.2	±0.3
M3	4.5	±0.35

Recommended Patterns

Ordering Information

WL	SN	054D	Z0	M	1R0	L	B
Product Code	Series	Dimensions	Series extension	Tolerance	Value	Packing Code	
WL: Inductor	SMD Unshielded Power Inductors	5.8 * 5.2 mm	Z0:STD	M: ± 20% L : ± 15% K : ± 10%	1R0 = 1.0uH 100 = 10.0uH	L=13" Reeled (Embossed tape)	B:STD

Electrical Characteristics

WLSN054D Series	Marking	L (uH)	Inductance Tolerance	Test Freq (KHz)	DCR (Ω) MAX.	Rated Current (A)
WLSN054DZ0M1R0LB	1R0	1.0	± 20%	100	0.015	4.00
WLSN054DZ0M1R9LB	1R9	1.9	± 20%	100	0.039	3.00
WLSN054DZ0M2R2LB	2R2	2.2	± 20%	100	0.020	4.00
WLSN054DZ0M3R3LB	3R3	3.3	± 20%	100	0.021	3.00
WLSN054DZ0M4R7LB	4R7	4.7	± 20%	100	0.028	2.00
WLSN054DZ0M6R8LB	6R8	6.8	± 20%	100	0.042	2.00
WLSN054DZ0M100LB	100	10	± 20%	100	0.10	1.44
WLSN054DZ0M120LB	120	12	± 20%	100	0.12	1.40
WLSN054DZ0M150LB	150	15	± 20%	100	0.14	1.30
WLSN054DZ0M180LB	180	18	± 20%	100	0.15	1.23
WLSN054DZ0M220LB	220	22	± 20%	100	0.18	1.11
WLSN054DZ0M270LB	270	27	± 20%	100	0.20	0.97
WLSN054DZ0L330LB	330	33	± 15%	100	0.23	0.88
WLSN054DZ0L390LB	390	39	± 15%	100	0.32	0.80
WLSN054DZ0L470LB	470	47	±15%	100	0.37	0.72
WLSN054DZ0K560LB	560	56	± 10%	100	0.42	0.68
WLSN054DZ0K680LB	680	68	± 10%	100	0.46	0.61
WLSN054DZ0K820LB	820	82	± 10%	100	0.60	0.58
WLSN054DZ0K101LB	101	100	± 10%	10	0.70	0.52
WLSN054DZ0K121LB	121	120	± 10%	10	0.93	0.48
WLSN054DZ0K151LB	151	150	± 10%	10	1.10	0.40
WLSN054DZ0K181LB	181	180	± 10%	10	1.38	0.38
WLSN054DZ0K221LB	221	220	± 10%	10	1.57	0.35
WLSN054DZ0K271LB	271	270	± 10%	10	1.85	0.30

a. Tolerance : M:±20%, L:±15%, K:±10%

b. Operating Temp : -25°C to +105°C.

c. Inductance measured using the HP4284A LCR meter, CHROMA1320 & 3302 & 16502

d. DCR measured using the 502BC milli-ohm meter.

e. Inductance drops no more than 10% of initial value at rated current, temperature rises $\Delta t < 40^\circ\text{C}$.

※MSL : LEVEL 1

TYPICAL RoHS REFLOW PROFILE

Typical RoHS Reflow Profile

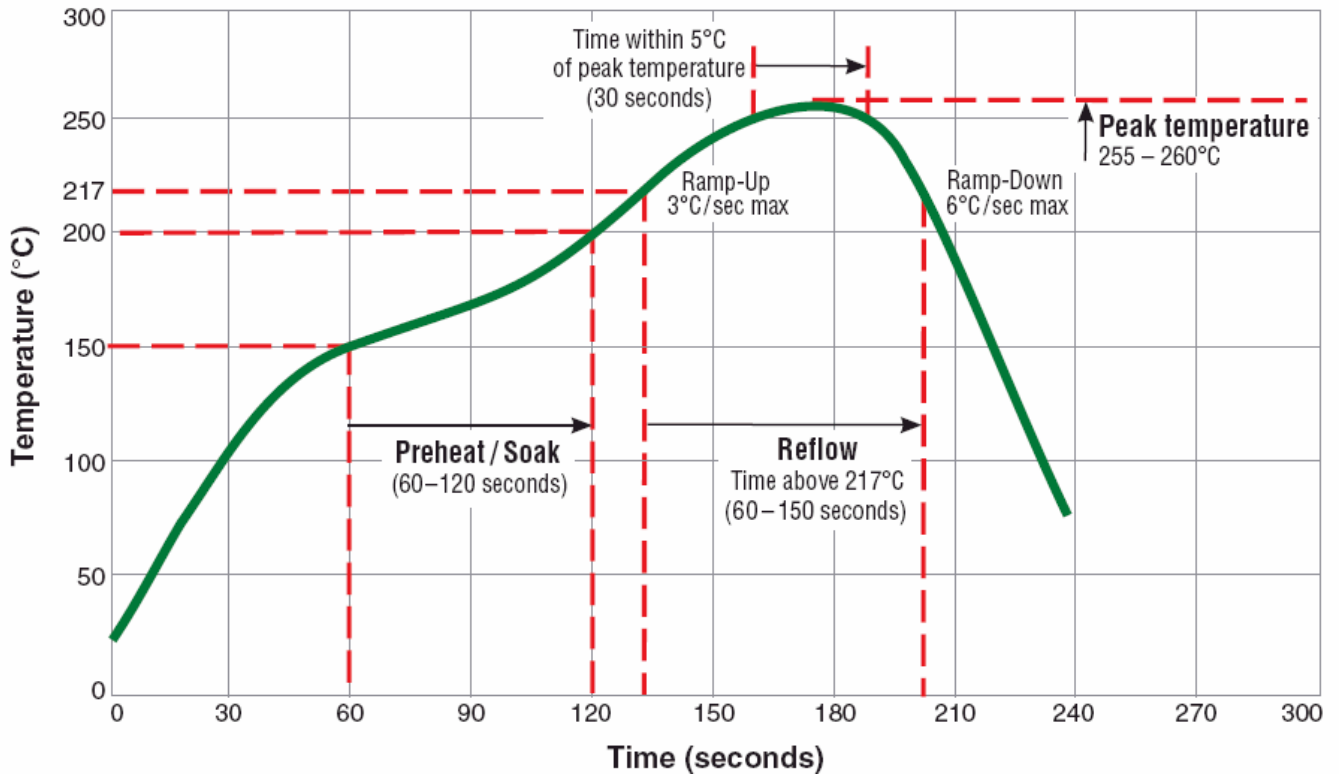

Mechanical Performance /Environmental Test Performance Specifications:

No.	Item	Test condition	Requirements
1	Salt Spray Test	Chamber temperature 35°C, the concentration of salt spray 5% (Total 24 hours).	MIL-STD-202G Method 101E Test Condition C
2	Humidity Test	+40°C ± 2°C, humidity of 90% ± 5% (total 96 hours).	MIL-STD-202G Method 103B Test Condition B
3	High Temperature Storage	1. Temperature: 125, 100, 85, 70, 55, 40, 30°C. 2. Test time: 2, 16, 72, 96 hours.	IEC 68-2 Test Condition B
4	Low Temperature Storage	1. Temperature: -40, -25, -10. 2. Test time: 2, 16, 72, 96 hours.	IEC 68-2 Test Condition A
5	Thermal Shock	+125°C ± 5°C (30 minutes) ~ -40 ± 5°C (30 minutes), temperature switch time: 5 minutes (total 50 cycles).	MIL-STD-202G Method 107G Test Condition B-2
6	Life Test	+100°C ± 2°C (1000Hour)	MIL-STD-202G Method 108A Test Condition D
7	Vibration Test	10-55-10HZ, amplitude: 1.5mm, direction: X, Y, Z axes, each axis 2 hours (total 6 hours).	MIL-STD-202G Method 201A
8	Solder Heat Resistance Test	DIP: Soak in 260°C solder pot, stay 10Sec Reflow: Keep 250 ± 5°C, 30 ± 5Sec in air, Temperature ramp: +1~4°C/sec; Above 183°C, must keep 90 s - 120 s.	MIL-STD-202G Method 210F Test Condition B(DIP) Test Condition (Reflow)
9	Terminal Pull Strength Test	1/2, 1, 2, 3, 5, 10 Pound, as products terminal feature.	MIL-STD-202G Method 211A Test Condition A
10	Solder Ability Test	Soak in 245 °C solder pot of 3Sec, PAD must have 95% above coverage.	J-STD-003B
11	Terminal Push Strength Test	No special requirements: 5N thrust to maintain 10 Sec.	JIS C5321:1997

Tape & Reel Packaging Dimensions:

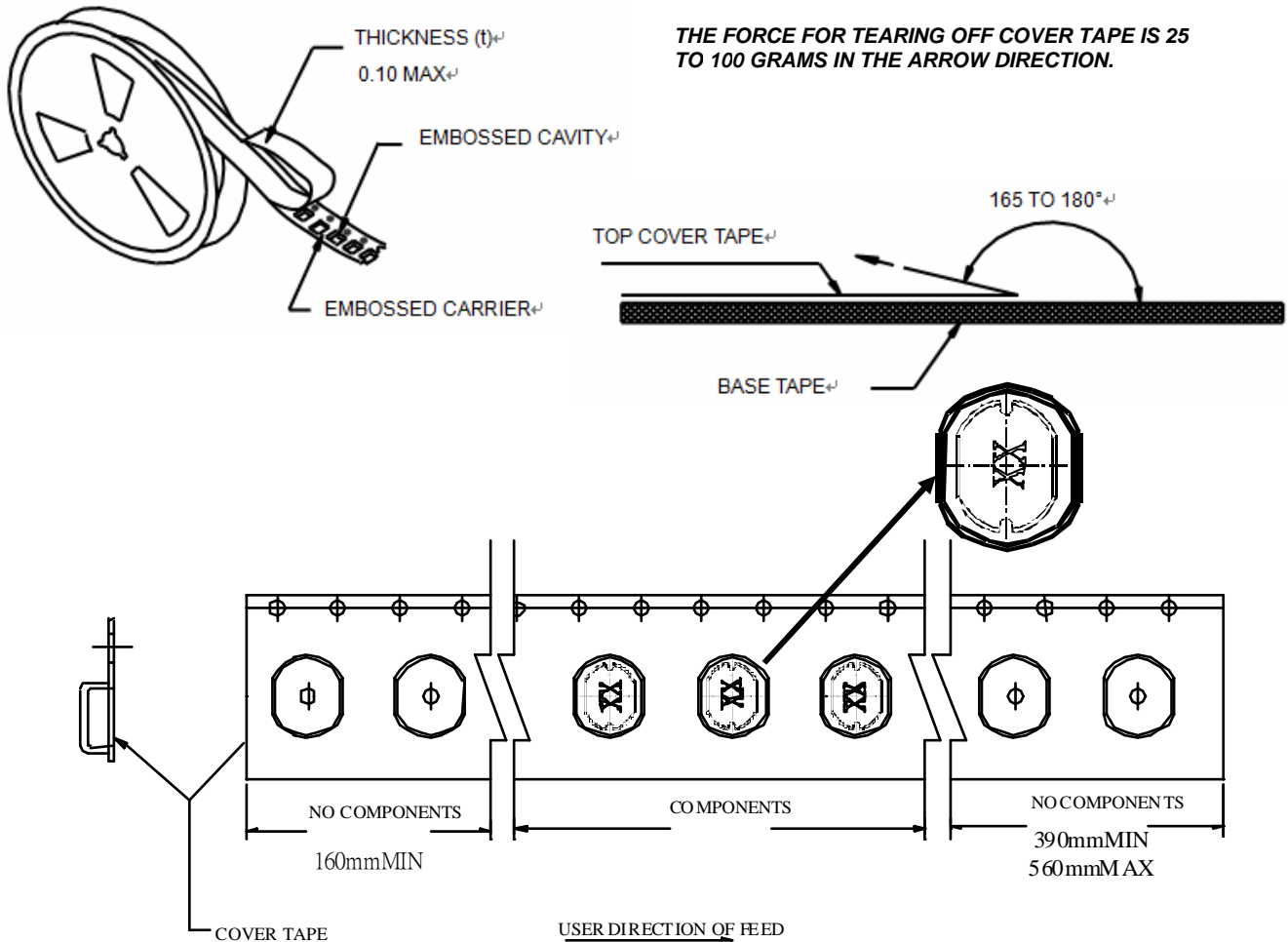

■ CARRIER TAPE

■ DIMENSIONS OF CARRIER

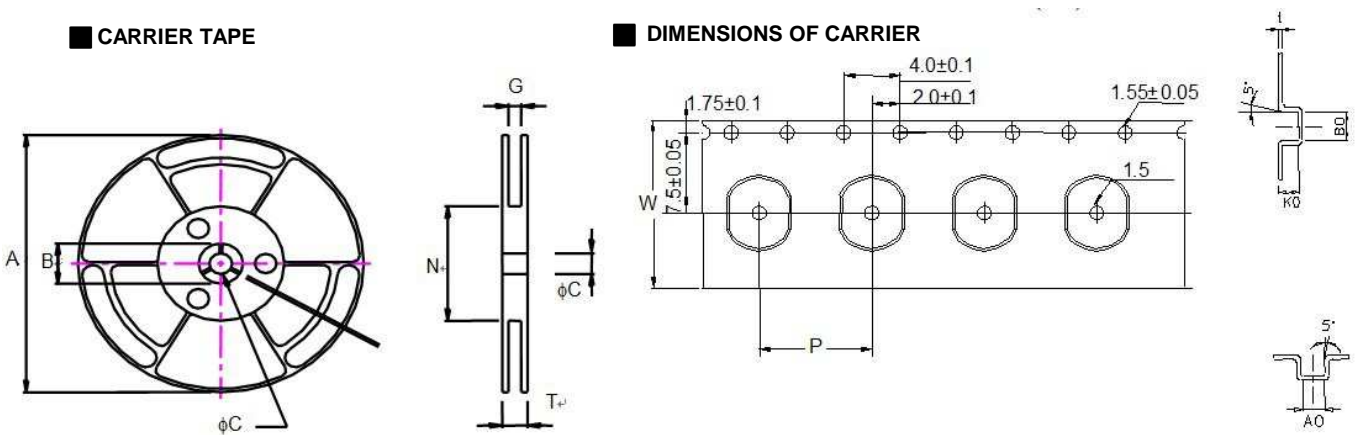

	A	B	C	G	N	P	T	W	t	A0	B0	K0
DIM.	360	21.0	13.0	12.4	80	12	18.4	12.0	0.35	5.4	6.3	5.0
TOL.	MAX	± 0.8	$+0.5-0.2$	$+2.0-0$	MIN.	± 0.1	MAX	± 0.3	± 0.05	± 0.1	± 0.1	± 0.1

Quantity per reel : 1K pcs