

APPROVAL SHEET

WLQC2929 Series SMD Square Air Wound Coil Inductors

*Contents in this sheet are subject to change without prior notice.

FEATURES

1. Excellence Q and SRF characteristics for RF application.
2. Wide range inductance and various tolerance options.
3. RoHS compliant

APPLICATIONS

1. Communication system front-end circuit: GSM/3G/LTE, Wi-Fi, GPS.
2. Cabel/Terrestrial/BS Tuner, Bluetooth, Wireless Audio, Remote control.
3. M2M: ZigBee, Proprietary wireless.
4. EMI solution in high frequency circuits.

Shape and Dimension

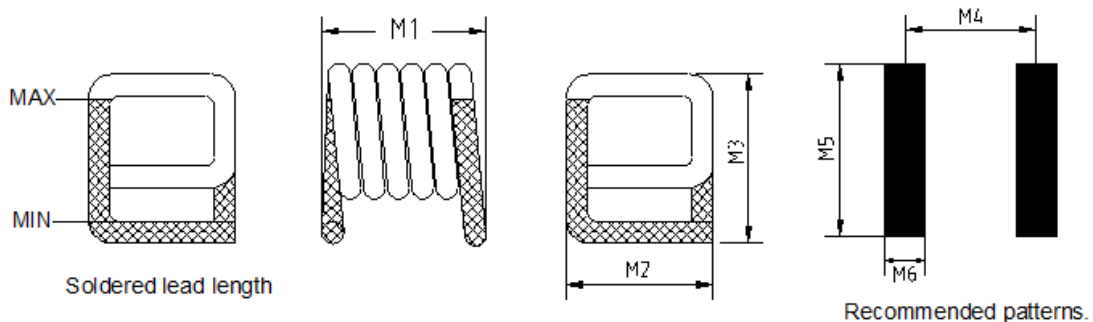

Unit: mm

WLQC2929 Series	M1	M2	M3	M4	M5	M6
WLQC2929H0□R33LB	10.29±0.381	7.49±0.254	7.24±0.254	9.53	8.26	2.29
WLQC2929H0□R36LB	11.30±0.381	7.49±0.254	7.24±0.254	10.541	8.26	2.29
WLQC2929H0□R39LB	12.32±0.381	7.49±0.254	7.24±0.254	11.56	8.26	2.29
WLQC2929H0□R43LB	13.21±0.381	7.49±0.254	7.24±0.254	12.45	8.26	2.29
WLQC2929H0□R50LB	14.00±0.381	7.49±0.254	7.24±0.254	13.21	8.26	2.29

Ordering Information

WL	QC	2929	H0	J	R33	L	B
Product Code	Series	Dimensions	Series extension	Tolerance	Value	Packing Code	
WL: Inductor	Square air wound coil inductor.	2929	H0	G: ± 2% J: ± 5%	R33 = 330nH R50 = 500nH	L=13" Reeled (Embossed Tape)	B:STD

Electrical Characteristics

WLQC2929 Series	Tolerance	L (nH)	Q (Typ)	Test Freq (MHz)	DCR (mΩ)Max	SRF (GHz) Min	Rated Current (A) Max
WLQC2929H0□R33LB	G、J	330	180	50	12.5	0.660	4.7
WLQC2929H0□R36LB	G、J	360	180	50	13.5	0.620	4.5
WLQC2929H0□R39LB	G、J	390	180	50	14.5	0.590	4.4
WLQC2929H0□R43LB	G、J	430	180	50	15.5	0.550	4.2
WLQC2929H0□R50LB	G、J	500	180	50	16.5	0.500	4.3

TEST INSTRUMENT : HP4291B / FIXTURE HP16193A

NOTE :

1. Inductance & Q measured on the HP4291B. With HP16193A test fixture.
2. Ambient temperature: -40°C to +125°C with Irms current, +125°C to +145°C with derated current.
3. Storage temperature Component:-40°C. TO +145°C, Packaging : -40°C. TO +80°C.
4. SRF measured using an Agilent/HP 8753 network analyzer.
5. Current that causes a 20°C temperature rise from 25°C ambient.
6. Tolerance:G=2%,J=5%

Characteristic Curve

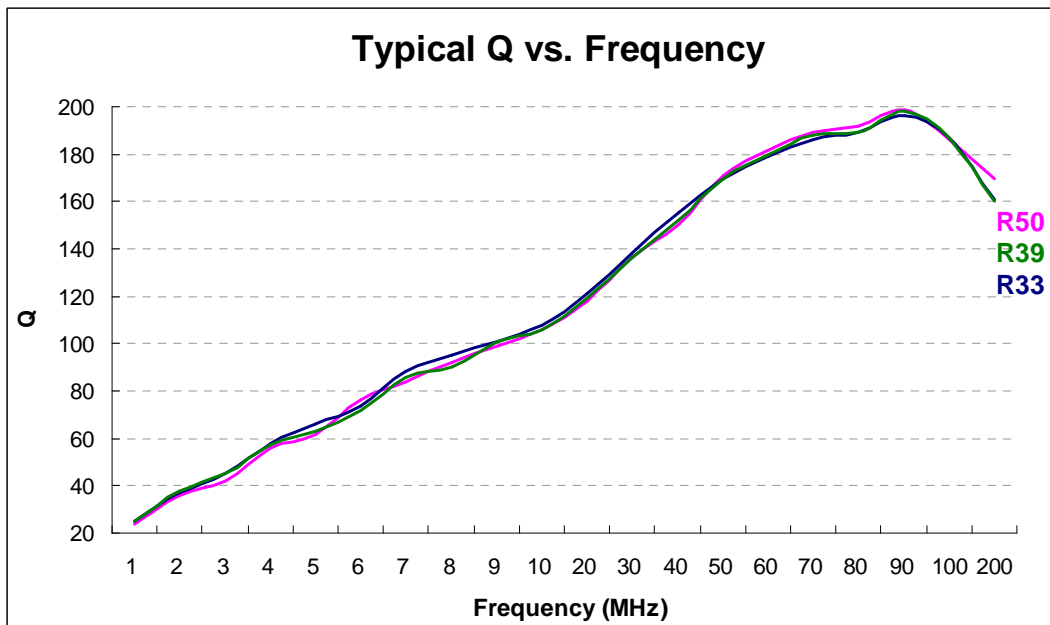
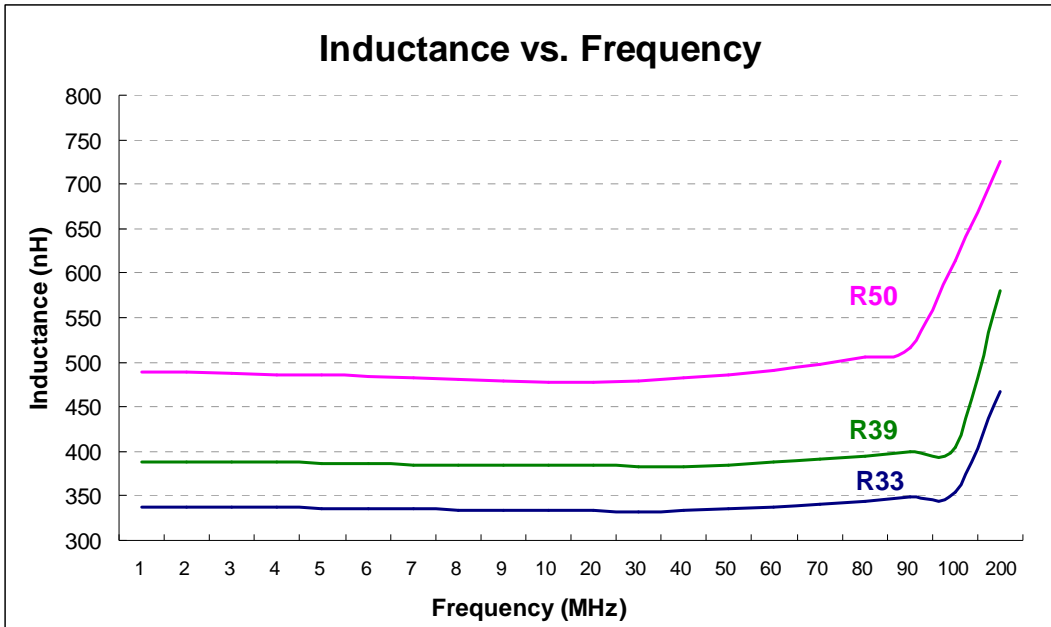

TYPICAL RoHS REFLOW PROFILE

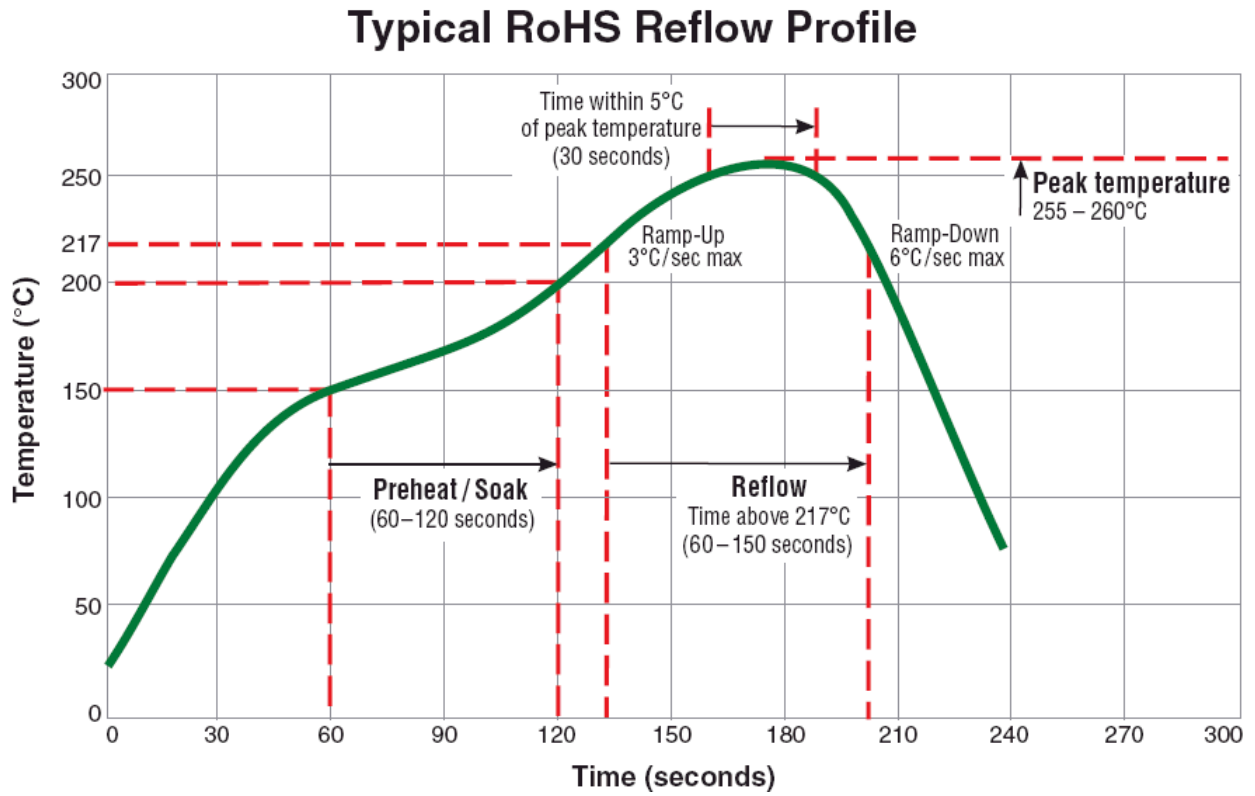

RELIABILITY PERFORMANCE

Reliability Experiment For Electrical

Test Item	Test Condition	Standard Source
Humidity Test	+40°C ± 2°C, humidity of 90% ± 5% (total 96 hours).	MIL-STD-202G Method 103B Test Condition B
High Temperature Test	1. Temperature: +125°C ± 2°C 2. Test time: 48 ± 2hrs	IEC 68-2 Test Condition B
Low Temperature Test	1. Temperature: -40°C ± 2°C 2. Test time: 48 ± 2hrs	IEC 68-2 Test Condition A
Thermal Shock	+125°C ± 5°C (30 minutes) ~ -40 ± 5°C (30 minutes), temperature switch time: 5 minutes (total 50 cycles).	MIL-STD-202G Method 107G Test Condition B-2
Life Test	+70°C ± 5°C (250Hours)	MIL-STD-202G Method 108A Test Condition B

Reliability Experiment For Physical

Test Item	Test Condition	Standard Source
Vibration Test	10-55-10HZ, amplitude: 1.5mm, direction: X, Y, Z axes, each axis 2 hours (total 6 hours).	MIL-STD-202G Method 201A
Solder Heat Resistance Test	IR/convection reflow: Peak Temp 250 ± 5°C for 5Sec in air, Through 2 Cycle. Temperature Ramp: +1~4°C/sec; Above 183°C, must keep 90 s - 120 s	MIL-STD-202G Method 210F Test Condition (Reflow)
Solder Ability Test	Soak in 245 °C solder pot of 3Sec, PAD must have 95% above coverage.	J-STD-003B

Packaging Specification

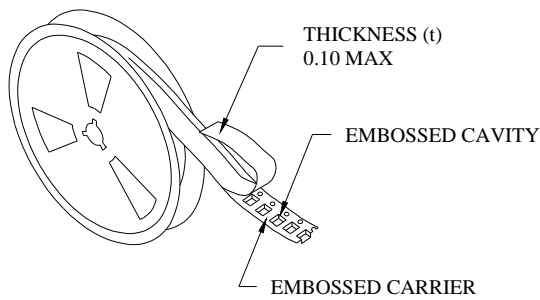

- THE FORCE FOR TEARING OFF COVER TAPE IS 10 TO 130 GRAMS IN THE ARROW DIRECTION.

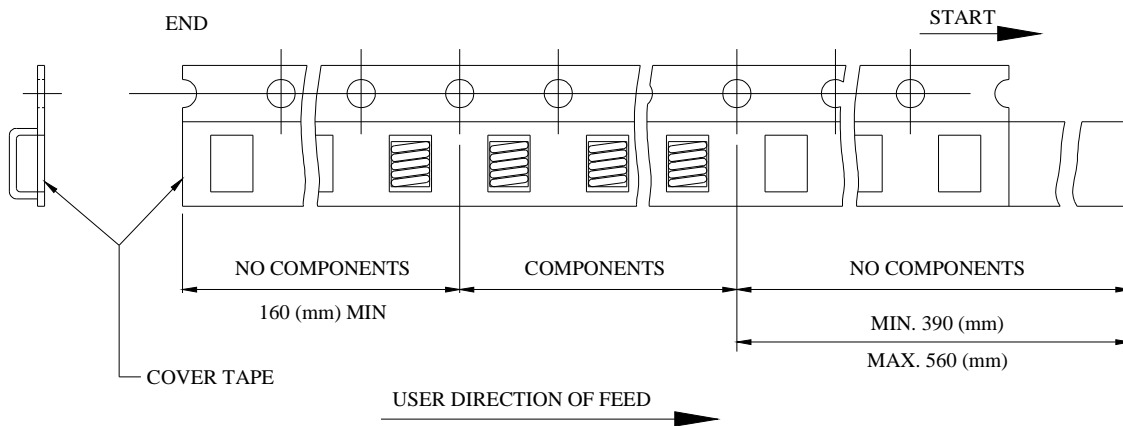
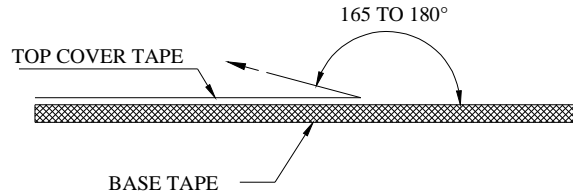

■ CARRIER TAPE REELS (mm)

MATERIAL: PLASTIC

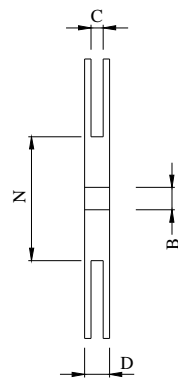
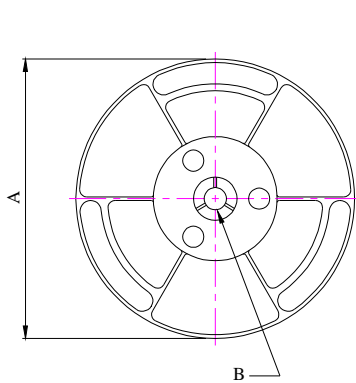

■ DIMENSIONS OF CARRIER TAPE (mm)

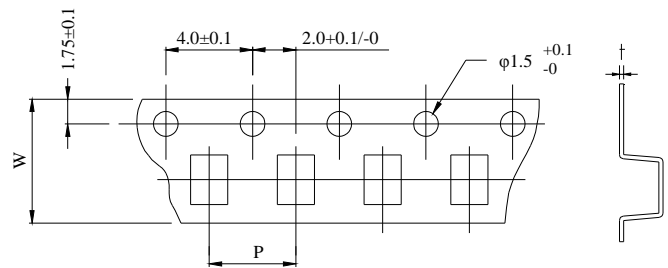

Unit: mm

ITEM	A	B	C	D	N	P	W	t
DIM.	330	13.0	24.5	30.4	100	12.0	24.0	0.4
TOL.	MAX.	±0.2	±0.2	MAX.	±0.5	±0.1	±0.3	±0.05

Quantity per reel : 600 pcs