

APPROVAL SHEET

WLQC1111 Series SMD Square Air Wound Coil Inductors

*Contents in this sheet are subject to change without prior notice.

FEATURES

1. Excellence Q and SRF characteristics for RF application.
2. Wide range inductance and various tolerance options.
3. RoHS compliant

APPLICATIONS

1. Communication system front-end circuit: GSM/3G/LTE, Wi-Fi, GPS.
2. Cabel/Terrestrial/BS Tuner, Bluetooth, Wireless Audio, Remote control.
3. M2M: ZigBee, Proprietary wireless.
4. EMI solution in high frequency circuits.

Shape and Dimension

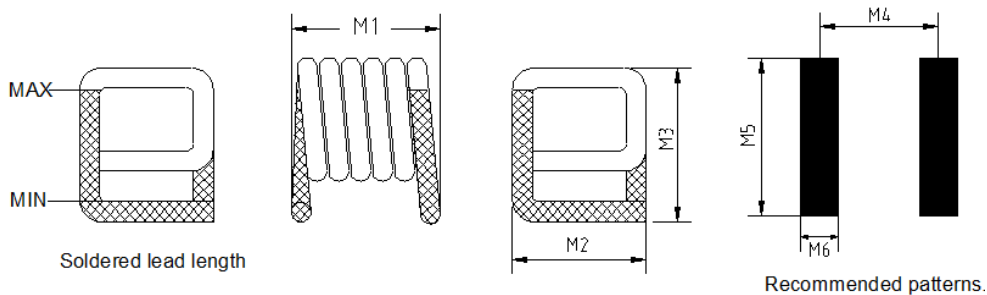

Unit: mm

WLQC1111 Series	M1	M2	M3	M4	M5	M6
WLQC1111H0□27NLB	2.67±0.254	2.67±0.127	2.79±0.127	2.29	3.05	1.02
WLQC1111H0□30NLB	2.67±0.254	2.67±0.127	2.79±0.127	2.29	3.05	1.02
WLQC1111H0□33NLB	2.92±0.254	2.67±0.127	2.79±0.127	2.54	3.05	1.02
WLQC1111H0□36NLB	2.92±0.254	2.67±0.127	2.79±0.127	2.54	3.05	1.02
WLQC1111H0□39NLB	2.92±0.254	2.67±0.127	2.79±0.127	2.54	3.05	1.02
WLQC1111H0□43NLB	3.30±0.254	2.67±0.127	2.79±0.127	2.79	3.05	1.02
WLQC1111H0□47NLB	3.30±0.254	2.67±0.127	2.79±0.127	2.79	3.05	1.02

Ordering Information

WL	QC	1111	H0	J	27N	L	B
Product Code	Series	Dimensions	Series extension	Tolerance	Value	Packing Code	
WL: Inductor	Square air wound coil inductor.	1111	H0	G: ± 2% J: ± 5%	27N = 27nH	L=13" Reeled (Embossed Tape)	B:STD

Electrical Characteristics

WLQC1111 Series	Tolerance	L (nH)	Q (min)	Test Freq (MHz)	DCR (mΩ)Max	SRF (GHz) Typ	Rated Current (A) Max
WLQC1111H0□27NLB	G、J	27	200	400	8.1	2.6	5.5
WLQC1111H0□30NLB	G、J	30	200	400	8.3	2.4	5.5
WLQC1111H0□33NLB	G、J	33	200	400	9.5	2.3	4.8
WLQC1111H0□36NLB	G、J	36	200	400	9.8	2.3	4.8
WLQC1111H0□39NLB	G、J	39	200	400	10.0	2.2	4.8
WLQC1111H0□43NLB	G、J	43	200	400	10.8	2.2	4.4
WLQC1111H0□47NLB	G、J	47	200	400	11.3	2.2	4.4

TEST INSTRUMENT : HP4291B / FIXTURE HP16193A

NOTE :

1. Inductance & Q measured on the HP4291B. With HP16193A test fixture.
2. Ambient temperature: -40°C to +125°C with Irms current, +125°C to +145°C with derated current.
3. Storage temperature Component: -40°C. TO +145°C, Packaging : -40°C. TO +80°C.
4. SRF measured using an Agilent/HP 8753 network analyzer.
5. Current that causes a 20°C temperature rise from 25°C ambient.
6. Tolerance: G=2%,J=5%
7. MSL:LEVEL 1

ELECTRICAL Curve

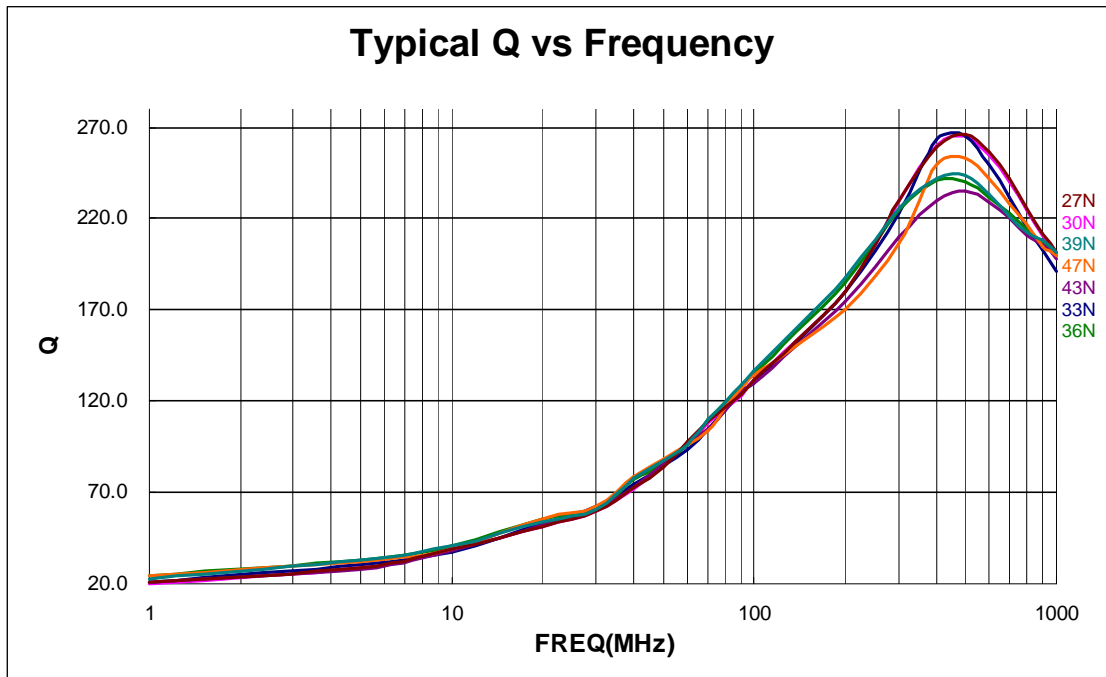
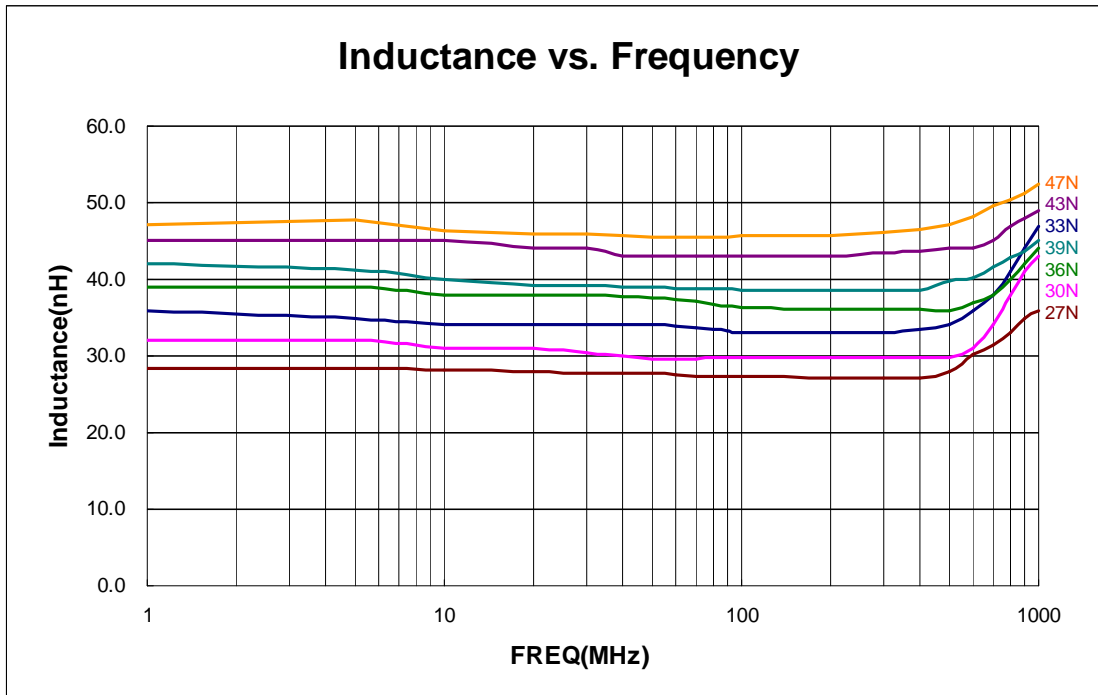

TYPICAL RoHS REFLOW PROFILE

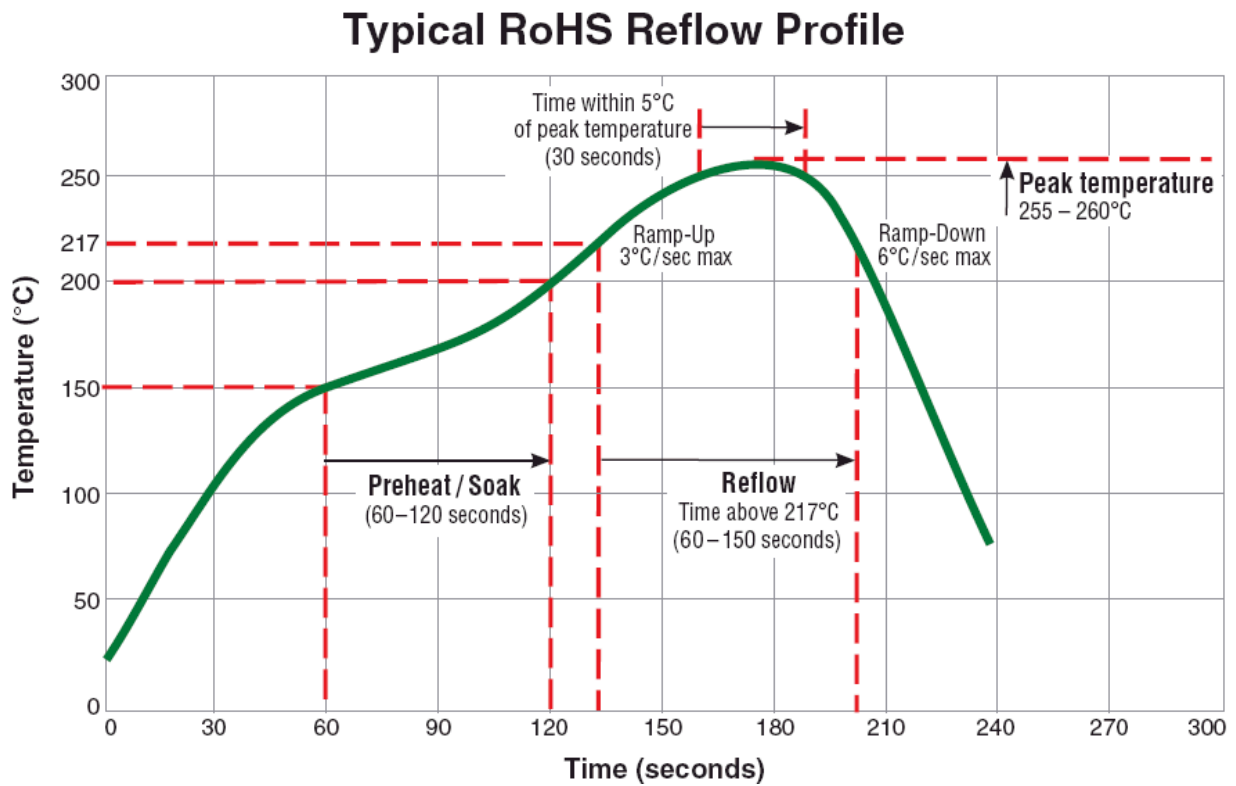

RELIABILITY PERFORMANCE

Reliability Experiment For Electrical

Test Item	Test Condition	Standard Source
Humidity Test	+40°C ± 2°C, humidity of 90% ± 5% (total 96 hours).	MIL-STD-202G Method 103B Test Condition B
High Temperature Test	1. Temperature: +125°C ± 2°C 2. Test time: 48 ± 2hrs	IEC 68-2 Test Condition B
Low Temperature Test	1. Temperature: -40°C ± 2°C 2. Test time: 48 ± 2hrs	IEC 68-2 Test Condition A
Thermal Shock	+125°C ± 5°C (30 minutes) ~ -40 ± 5°C (30 minutes), temperature switch time: 5 minutes (total 50 cycles).	MIL-STD-202G Method 107G Test Condition B-2
Life Test	+70°C ± 5°C (250Hours)	MIL-STD-202G Method 108A Test Condition B

Reliability Experiment For Physical

Test Item	Test Condition	Standard Source
Vibration Test	10-55-10HZ, amplitude: 1.5mm, direction: X, Y, Z axes, each axis 2 hours (total 6 hours).	MIL-STD-202G Method 201A
Solder Heat Resistance Test	IR/convection reflow: Peak Temp 250 ± 5°C for 5Sec in air, Through 2 Cycle. Temperature Ramp: +1 ~ 4°C/sec; Above 183°C, must keep 90 s - 120 s	MIL-STD-202G Method 210F Test Condition (Reflow)
Solder Ability Test	Soak in 245 °C solder pot of 3Sec, PAD must have 95% above coverage.	J-STD-003B

Packaging Specification

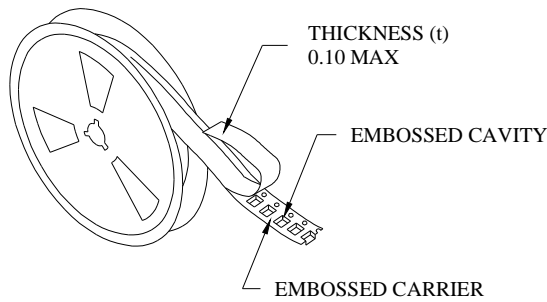

- THE FORCE FOR TEARING OFF COVER TAPE IS 10 TO 130 GRAMS IN THE ARROW DIRECTION.

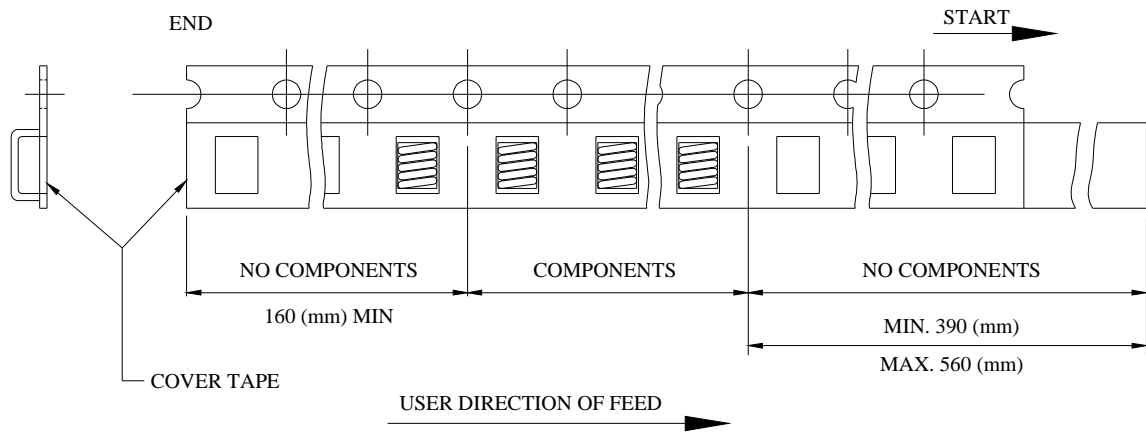
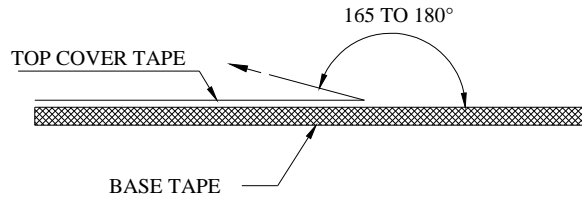

■ CARRIER TAPE REELS (mm)

MATERIAL: PLASTIC

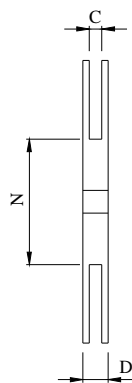
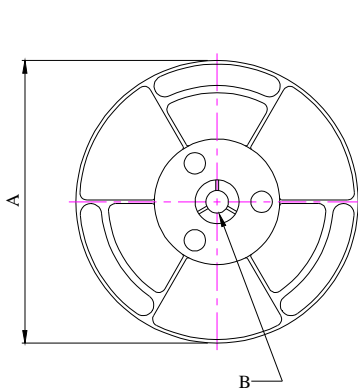

■ DIMENSIONS OF CARRIER TAPE (mm)

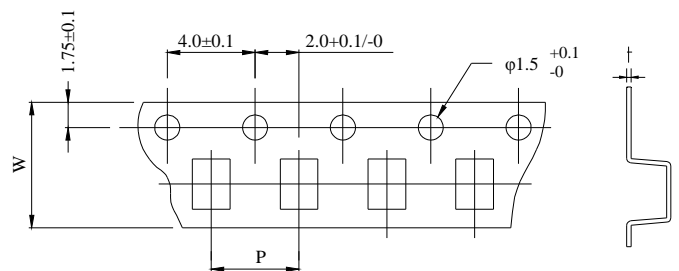

Unit: mm

ITEM	A	B	C	D	N	P	W	t
DIM.	330	13.0	12.4	18.4	100	8.0	12.0	0.35
TOL.	MAX.	±0.2	±0.2	MAX.	±0.5	±0.1	±0.3	±0.05

Quantity per reel : 2500 pcs