

APPROVAL SHEET

WLPMA0A040*LC Series SMD Molded Power Inductors

*Contents in this sheet are subject to change without prior notice.

Features

1. Shielded construction.
2. Ultra low buzz noise.
3. Low DCR/ μ H.
4. Handles high transient current spikes without saturation.
5. Encapsulated body offers improved environmental protection and moisture resistance.
6. Higher dielectric withstanding voltage.
7. Corrosion resistant package.
8. RoHS Compliance.

Applications

1. PDA/Notebook/Desktop/Server applications high current and low profile power supplier.
2. High current POL converters.
3. Battery powered devices.

Shape and Dimension

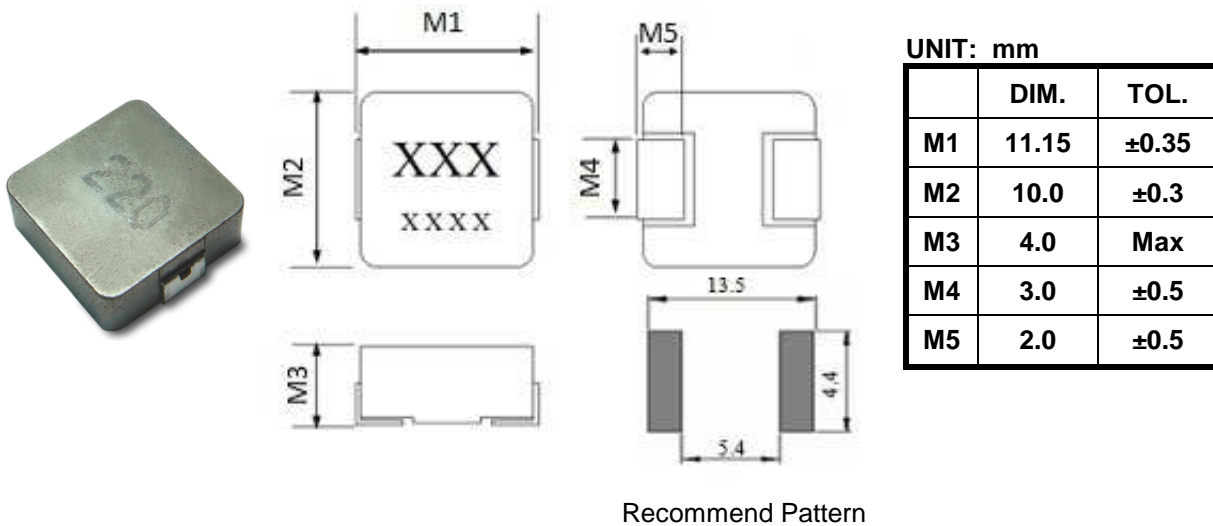

MARKING AND DATE CODE

Marking ex:1.0uH \rightarrow 1R0

Date code

XX XX \rightarrow year and weekly ex:1033

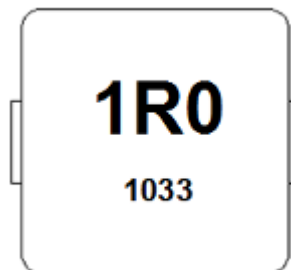

Ordering Information

WL	PM	A0A0	40	M	R22	L	C
Product Code WL: Inductor	Series SMD Molded power inductor.	Dimensions 11.15 * 10mm	Thickness 3.8mm	Tolerance M: ± 20%	Value R22=0.22uH 2R2=2.2uH 220=22.0uH	Packing Code L=13" Reeled (Embossed tape)	C:

Electrical Characteristics

WLPMA0A040*LC series

Walsin Part Number	L(uH)	Tolerance	Measuring Frequency (kHz),1V	RDC Maximum (mΩ)		Rated Current Typical (A)	I sat Typical (A)
				TYP.	MAX.		
WLPMA0A040MR22LC	0.22	M	100	0.8	1	30	50
WLPMA0A040MR36LC	0.36	M	100	1.1	1.2	34	40
WLPMA0A040MR47LC	0.47	M	100	1.3	1.55	25	35
WLPMA0A040MR56LC	0.56	M	100	1.6	1.8	25	32
WLPMA0A040MR68LC	0.68	M	100	2.4	2.7	22	30
WLPMA0A040M1R0LC	1.0	M	100	3	3.3	18	28
WLPMA0A040M1R5LC	1.5	M	100	3.8	4.2	16	21
WLPMA0A040M2R2LC	2.2	M	100	6.7	7	12	18
WLPMA0A040M3R3LC	3.3	M	100	10.8	11.8	10	16
WLPMA0A040M4R7LC	4.7	M	100	17	20	8.5	15
WLPMA0A040M6R8LC	6.8	M	100	22.5	25	6.5	9
WLPMA0A040M8R2LC	8.2	M	100	26.0	29.0	7.0	9.0
WLPMA0A040M100LC	10.0	M	100	27.0	30.0	7.5	8.5
WLPMA0A040M150LC	15.0	M	100	40.0	45.0	6.25	7.0
WLPMA0A040M220LC	22.0	M	100	60.0	66.0	5.0	5.5
WLPMA0A040M330LC	33.0	M	100	85.0	92.0	4.4	5.0
WLPMA0A040M470LC	47.0	M	100	130.0	145.0	3.3	3.5
WLPMA0A040M560LC	56.0	M	100	150.0	170.0	3.8	2.8
WLPMA0A040M680LC	68.0	M	100	175.0	200.0	3.5	2.6

TEST INSTRUMENT: CHROMA 16502 、Zentech1320+Zentech3305

- (1). Test Freq : 100KHz , 1V
- (2). All test data is referenced to 25°C ambient.
- (3). Operating Temperature Range -55°C to +125°C.
- (4). Rated Current: DC current(A)that will cause an approximate ΔT of 40°C.
- (5). I sat: DC current(A)that will cause Lo to drop approximately 30%.
- (6). The part temperature(ambient +temp rise)should not exceed 125°C under worst case operating conditions. Circuit design, component placement, PWB trace size and thickness, airflow and other cooling provisions all affect the part temperature Part temperature should be verified

RELIABILITY PERFORMANCE

Reliability Experiment For Electrical

Test Item	Test Condition	Standard Source
Humidity Test	+40°C ± 2°C, humidity of 90% ± 5% (total 96 hours).	MIL-STD-202G Method 103B Test Condition B
High Temperature Test	1.Temperature: +125°C ± 2°C 2.Test time: 48 ± 2hrs	IEC 68-2 Test Condition B
Low Temperature Test	1.Temperature: -40°C ± 2°C 2.Test time: 48 ± 2hrs	IEC 68-2 Test Condition A
Thermal Shock	+125°C ± 5°C (30 minutes) ~ -40 ± 5°C (30 minutes), temperature switch time: 5 minutes (total 50 cycles).	MIL-STD-202G Method 107G Test Condition B-2
Life Test	+70°C ± 5°C (250Hours)	MIL-STD-202G Method 108A Test Condition B

Reliability Experiment For Physical

Test Item	Test Condition	Standard Source
Vibration Test	10-55-10HZ, amplitude: 1.5mm, direction: X, Y, Z axes, each axis 2 hours (total 6 hours).	MIL-STD-202G Method 201A
Solder Heat Resistance Test	IR/convection reflow: Peak Temp 250 ± 5°C for 5Sec in air, Through 2 Cycle. Temperature Ramp: +1 ~ 4°C/sec; Above 183°C, must keep 90 s - 120 s	MIL-STD-202G Method 210F Test Condition (Reflow)
Solder Ability Test	Soak in 245 °C solder pot of 3Sec, PAD must have 95% above coverage.	J-STD-003B

TYPICAL RoHS REFLOW PROFILE

Typical RoHS Reflow Profile

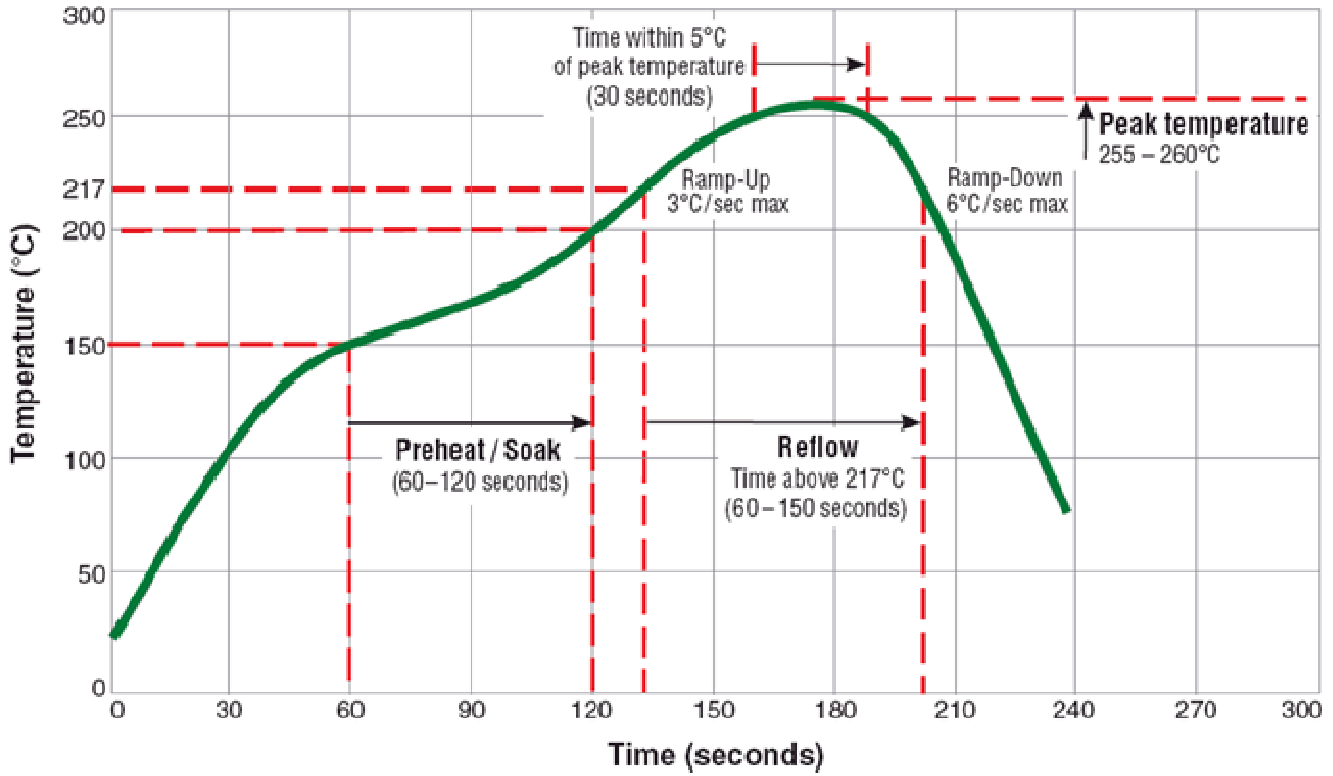

Packaging

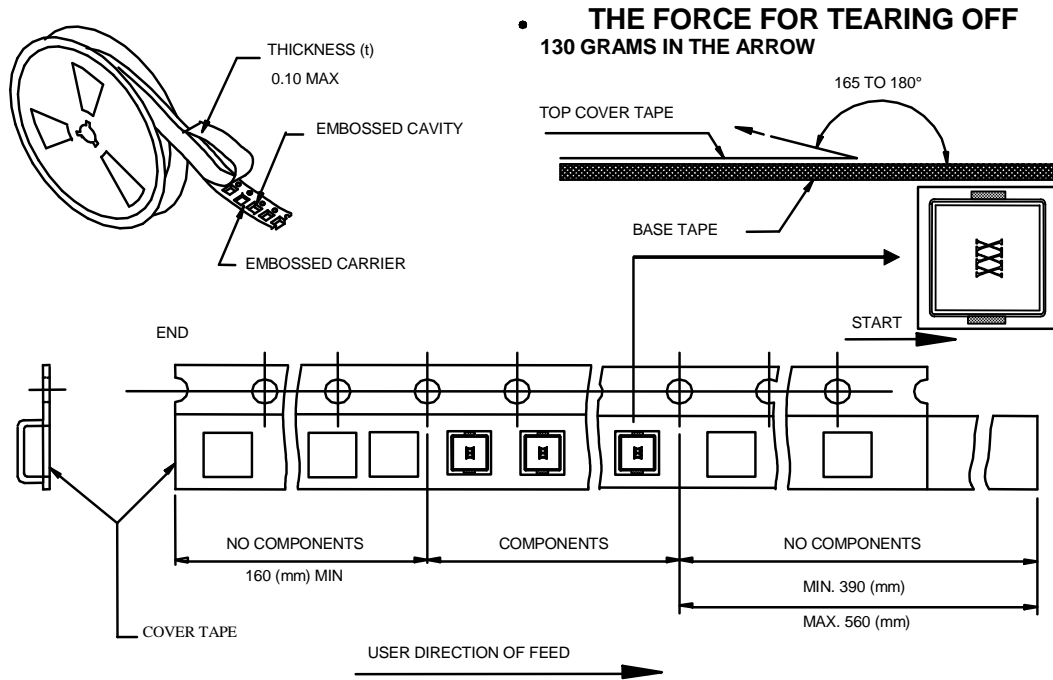

CARRIER TAPE REELS (mm)

MATERIAL: PLASTIC

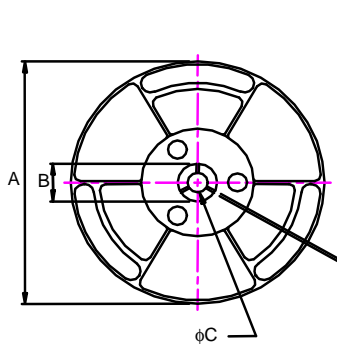

DIMENSIONS OF CARRIER TAPE (mm)

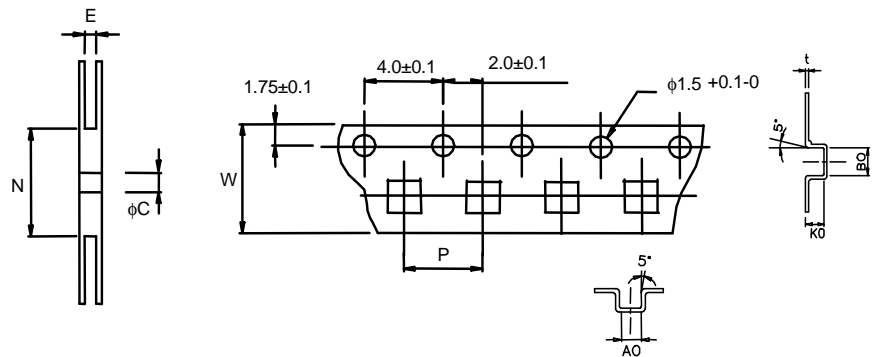

※ 10 sprocket hole pitch cumulative tolerance ±0.20

UNIT : mm

	A	B	C	E	N	P	W	t	A0	B0	K0
DIM.	330	25.0	13.0	24.6	100	16.0	24.0	0.4	10.6	11.7	4.25
TOL.	±0.2	±0.5	±0.5	±0.5	MIN	±0.1	±0.3	±0.05	±0.1	±0.1	±0.1

Quantity per reel : 500 pcs