

APPROVAL SHEET

WLCW2520HQ SMD Wire Wound Ceramic Chip Inductors (High Q)

*Contents in this sheet are subject to change without prior notice.

Features

1. Standard chip size bobbin with wire wound coil provides high reliability, productivity and performance.
2. WLCW2520HQ Series offers higher Q factors. In addition, current handling has been improved with significantly lower DCR values. Like all wire wound ceramic chip inductors, the WLCW2520HQ Series provides exceptional SRFs, tight inductance tolerance and batch consistency.
3. Wide range inductance and various tolerance options.
4. RoHS compliant.

Applications

1. Communication: GSM/3G/LTE, Wi-Fi, GPS.
2. Consumer: Cabel/Terrestrial/BS Tuner, Bluetooth, Wireless Audio, Remote control.
3. M2M: ZigBee, Proprietary wireless.

Shape and Dimension

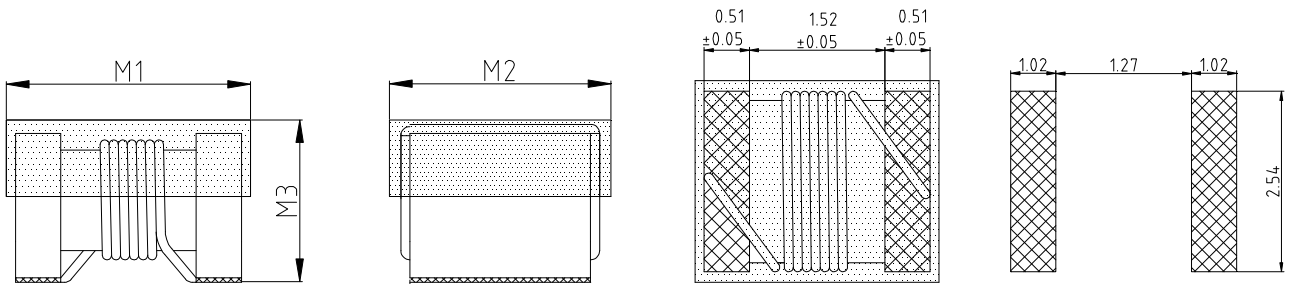

Unit: mm

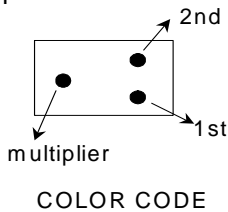

Example : WLCW2520HQ□3N0PB
MARKING : Dots 1 and 2 indicate the inductance in nano Henries.
 (DOTS 1 : ORANGE , DOTS 2 : BLACK)
 Dots 3 indicates number of zeroes to be added.
 (DOTS 3 : BLACK)

WLCW Series	M1	M2	M3
2520HQ	2.92(MAX)	2.79(MAX)	2.03(MAX)

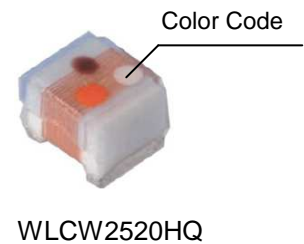

Ordering Information

WL	CW	2520	HQ	J	3N0	P	B
Product Code	Series	Dimensions	Series extension	Tolerance	Value	Packing Code	
WL: Inductor	SMD Wire Wound Ceramic Chip inductor.	2520 :EIA 1008	HQ: Higher Q & Lower DCR	G: ± 2% J: ± 5%	3n0 =3.0nH 10N =10.0nH R10=100nH	P=7" Reeled (Embossed tape)	B:STD

Electrical Characteristics

WLCW2520HQ series

Walsin Part Number	L (nH)	Tolerance	Measuring Frequency (MHz)	Q (Min)	Test Freq (MHz)	SRF (GHz) Min	RDC Max (Ω)	I _{rms} (mA)	Color Code		
									1st	2nd	multiplier
WLCW2520HQ□3N0PB	3.0	J	50	70	1500	8.10	0.04	1.6	ORANGE	BLACK	BLACK
WLCW2520HQ□4N1PB	4.1	J	50	75	1500	6.20	0.05	1.6	YELLOW	BROWN	BLACK
WLCW2520HQ□7N8PB	7.8	J	50	75	500	3.80	0.05	1.6	VIOLET	GRAY	BLACK
WLCW2520HQ□10NPB	10	J	50	60	500	3.60	0.06	1.6	BROWN	BLACK	BROWN
WLCW2520HQ□12NPB	12	J、G	50	70	500	2.80	0.06	1.5	BROWN	RED	BROWN
WLCW2520HQ□18NPB	18	J、G	50	62	350	2.70	0.07	1.4	BROWN	GRAY	BROWN
WLCW2520HQ□22NPB	22	J、G	50	62	350	2.05	0.07	1.4	RED	RED	BROWN
WLCW2520HQ□33NPB	33	J、G	50	75	350	1.70	0.09	1.3	ORANGE	ORANGE	BROWN
WLCW2520HQ□36NPB	36	J、G	50	65	350	1.40	0.09	1.3	ORANGE	BLUE	BROWN
WLCW2520HQ□39NPB	39	J、G	50	75	350	1.30	0.09	1.3	ORANGE	WHITE	BROWN
WLCW2520HQ□47NPB	47	J、G	50	75	350	1.45	0.12	1.2	YELLOW	VIOLET	BROWN
WLCW2520HQ□56NPB	56	J、G	50	75	350	1.23	0.12	1.2	GREEN	BLUE	BROWN
WLCW2520HQ□68NPB	68	J、G	50	80	350	1.15	0.13	1.1	BROWN	GRAY	BROWN
WLCW2520HQ□82NPB	82	J、G	50	80	350	1.06	0.16	1.1	GRAY	RED	BROWN
WLCW2520HQ□R10PB	100	J、G	25	62	350	0.82	0.16	1.0	BROWN	BLACK	RED

Tolerance : J : $\pm 5\%$ 、G : $\pm 2\%$

OPERATING TEMPERATURE : $-40^{\circ}\text{C} \sim 125^{\circ}\text{C}$

※MSL : LEVEL 1

L、Q : TESTED BY AGILENT 4287A with 16197A or its equivalent

SRF : TESTED BY HP 8753E or HP4291B with 16193A or its equivalent

DCR: TESTED BY AGILENT 4338B or its equivalent

RELIABILITY PERFORMANCE

Reliability Experiment For Electrical

Test Item	Test Condition	Standard Source
Humidity Test	+40°C ± 2°C, humidity of 90% ± 5% (total 96 hours).	MIL-STD-202G Method 103B Test Condition B
High Temperature Test	1. Temperature: +125°C ± 2°C 2. Test time: 48 ± 2hrs	IEC 68-2 Test Condition B
Low Temperature Test	1. Temperature: -40°C ± 2°C 2. Test time: 48 ± 2hrs	IEC 68-2 Test Condition A
Thermal Shock	+125°C ± 5°C (30 minutes) ~ -40 ± 5°C (30 minutes), temperature switch time: 5 minutes (total 50 cycles).	MIL-STD-202G Method 107G Test Condition B-2
Life Test	+70°C ± 5°C (250Hours)	MIL-STD-202G Method 108A Test Condition B

Reliability Experiment For Physical

Test Item	Test Condition	Standard Source
Vibration Test	10-55-10HZ, amplitude: 1.5mm, direction: X, Y, Z axes, each axis 2 hours (total 6 hours).	MIL-STD-202G Method 201A
Solder Heat Resistance Test	IR/convection reflow: Peak Temp 250 ± 5°C for 5Sec in air, Through 2 Cycle. Temperature Ramp: +1~4°C/sec; Above 183°C, must keep 90 s - 120 s	MIL-STD-202G Method 210F Test Condition (Reflow)
Solder Ability Test	Soak in 245 °C solder pot of 3Sec, PAD must have 95% above coverage.	J-STD-003B

Typical RoHS Reflow Profile

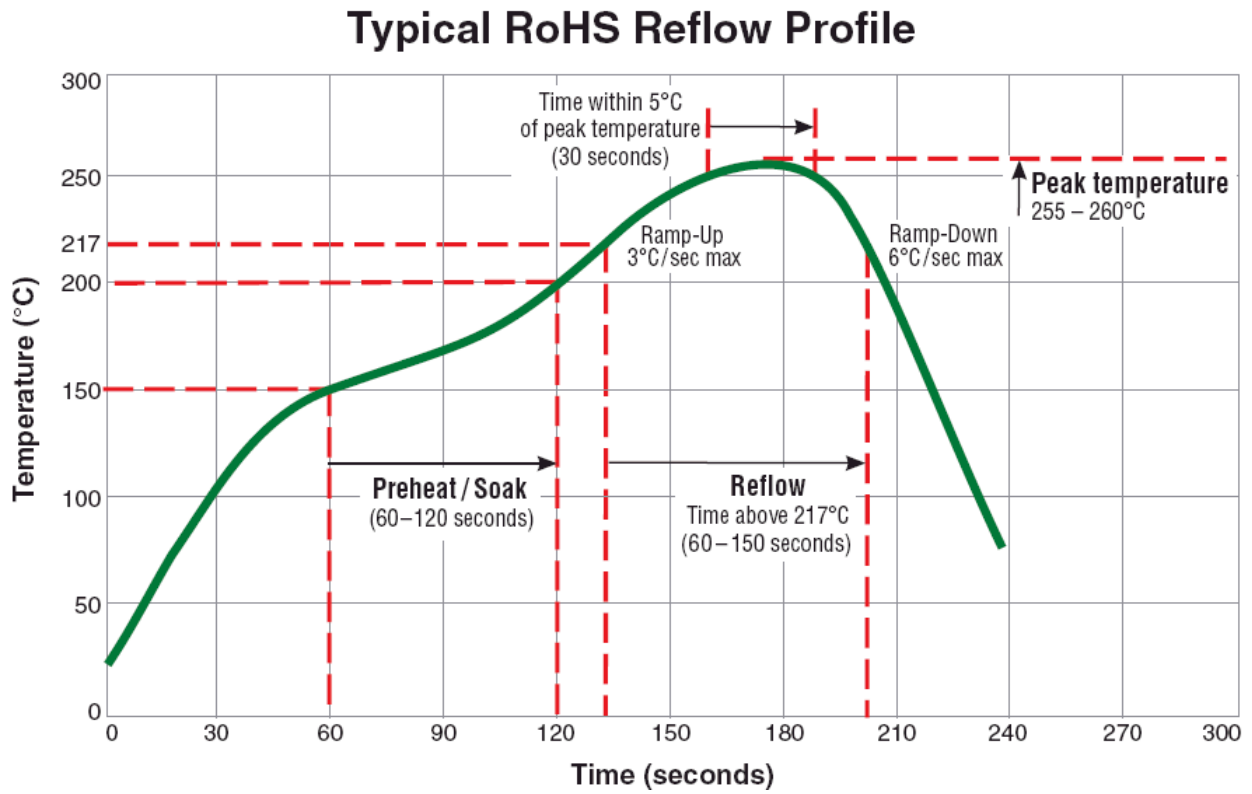

Packaging Specification

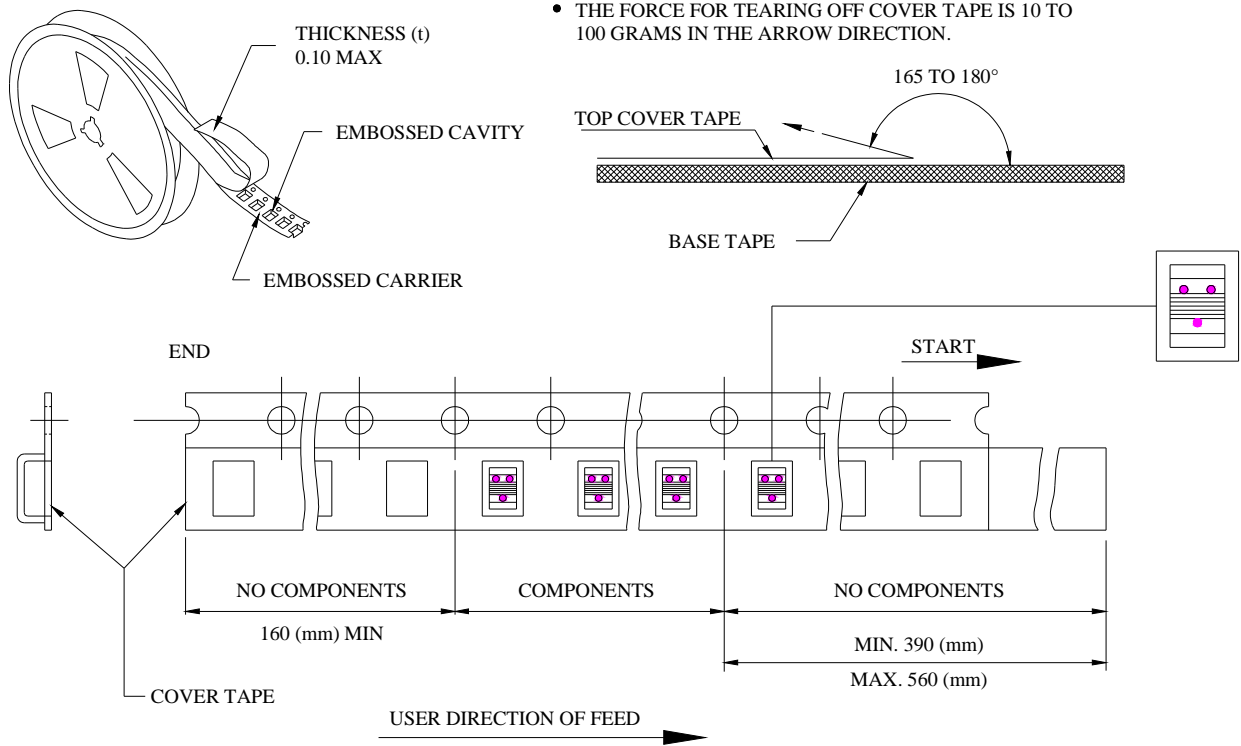

■ CARRIER TAPE REELS (mm)

MATERIAL: PLASTIC

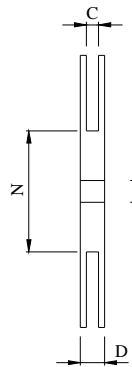
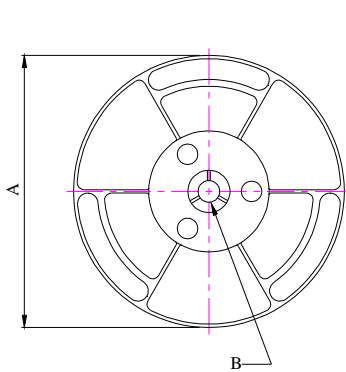

■ DIMENSIONS OF CARRIER TAPE (mm)

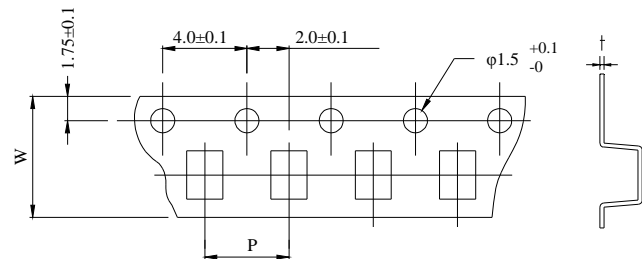

	A	B	C	D	N	P	W	t
DIM.	178	13.0	8.4	12.5	50	4.0	8.0	0.26
TOL.	±2.0	±0.8	-	-	MIN	±0.1	±0.2	±0.05

Quantity per reel : 2K pcs