

APPROVAL SHEET

WLAC291A Series
WLAC291B Series
SMD Air Wound Coil Inductors

*Contents in this sheet are subject to change without prior notice.

Features

Acrylic jacket(WLAC291) provides a flat top for pick and place

1. Acrylic cap provides a flat top for pick and place machine for high productive manufacture.
2. Excellent Q and SRF characteristics for RF application, escipally in subGHz band.
3. Narrow tolerance available for precise design requirements.

Applications

1. Communication system front-end circuit: GSM/3G/LTE, Wi-Fi, GPS.
2. Cabel/Terrestrial/BS Tuner, Bluetooth, Wireless Audio, Remote control.
3. M2M: ZigBee, Proprietary wilreless.
4. EMI solution in high frequency circuits.

Shape and Dimension

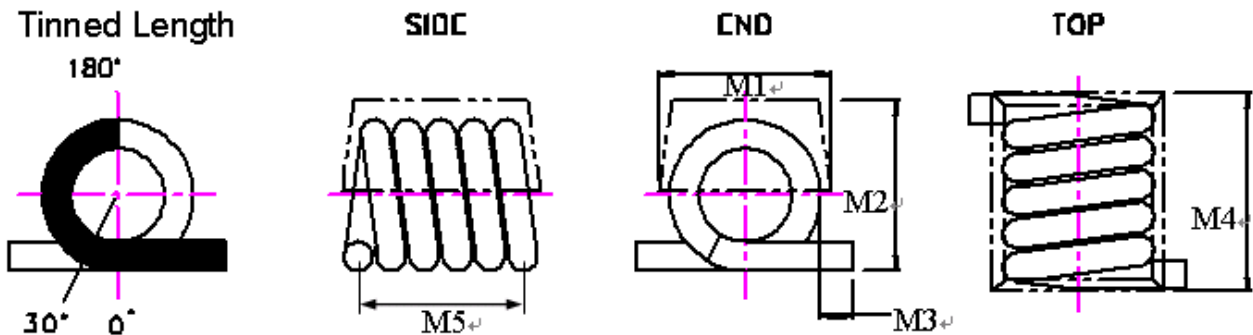

TINNED LENGTH BETWEEN 30° AND 180°

Recommend Patterns

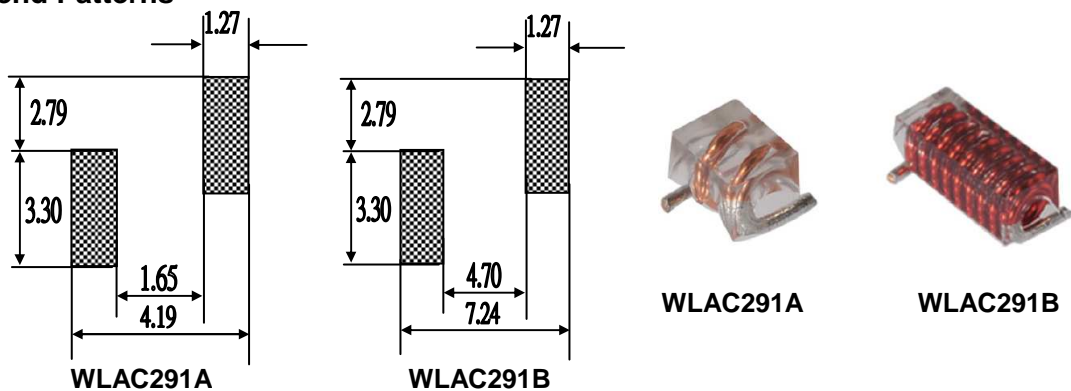

Unit: mm

WLAC Series	M1	M2	M3	M4	M5
291A	3.05 (Max)	3.18 (Max)	0.58±0.38	3.68 (Max)	2.92±0.25
291B	3.05 (Max)	3.18 (Max)	0.58±0.38	6.86 (Max)	5.84±0.25

Ordering Information

WL	AC	291A	Z0	K	T01	P	B
Product Code	Series	Dimensions	Series Extension	Tolerance	Turns	Packing Code	
WL: Inductor	Air wound coil inductor.	291A 291B	Z0:STD	G: $\pm 2\%$ J: $\pm 5\%$ K: $\pm 10\%$	T01=1 Turns T03=3 Turns T10=10 Turns	P=7" Reeled (Embossed reel)	B:STD

Electrical Characteristics

● WLAC291A series

Walsin Part Number	L(nH)	Tolerance	Turns	Q Min	Typical Q @ Frequency (MHz)	SRF Typical (GHz)	RDC Maximum (m Ω)	Rated Current (A)
WLAC291AZ0□T01PB	2.5	K	1	145	150	12.5	1.1	4.0
WLAC291AZ0□T02PB	5.0	G,J	2	140	150	6.5	1.8	4.0
WLAC291AZ0□T03PB	8.0	G,J	3	140	150	5.0	2.6	4.0
WLAC291AZ0□T04PB	12.5	G,J	4	137	150	3.3	3.4	4.0
WLAC291AZ0□T05PB	18.5	G,J	5	132	150	2.5	3.9	4.0

● WLAC291B series

Walsin Part Number	L(nH)	Tolerance	Turns	Q Min	Typical Q @ Frequency (MHz)	SRF Typical (GHz)	RDC Maximum (m Ω)	Rated Current (A)
WLAC291BZ0□T06PB	17.5	G,J	6	100	150	2.2	4.5	4.0
WLAC291BZ0□T07PB	22.0	G,J	7	102	150	2.1	5.2	4.0
WLAC291BZ0□T08PB	28.0	G,J	8	105	150	1.8	6.0	4.0
WLAC291BZ0□T09PB	35.5	G,J	9	112	150	1.5	6.8	4.0
WLAC291BZ0□T10PB	43.0	G,J	10	106	150	1.2	7.9	4.0

TOLERANCE : K: $\pm 10\%$, J: $\pm 5\%$, G: $\pm 2\%$

※TEST INSTRUMENT: HP4291B、FIXTURE HP16193A、HP8753E、CHROMA16502

NOTE :

1. Inductance & Q measured on the HP4291B. With HP16193 test fixture.
2. Operating temp. : -40°C to $+125^{\circ}\text{C}$
3. For temperature rise : 15°C
4. SRF measured using the HP8753E

RELIABILITY PERFORMANCE

Reliability Experiment For Electrical

Test Item	Test Condition	Standard Source
Humidity Test	+40°C ± 2°C, humidity of 90% ± 5% (total 96 hours).	MIL-STD-202G Method 103B Test Condition B
High Temperature Test	1.Temperature: +125°C ± 2°C 2.Test time: 48 ± 2hrs	IEC 68-2 Test Condition B
Low Temperature Test	1.Temperature: -40°C ± 2°C 2.Test time: 48 ± 2hrs	IEC 68-2 Test Condition A
Thermal Shock	+125°C ± 5°C (30 minutes) ~ -40 ± 5°C (30 minutes), temperature switch time: 5 minutes (total 50 cycles).	MIL-STD-202G Method 107G Test Condition B-2
Life Test	+70°C ± 5°C (250Hours)	MIL-STD-202G Method 108A Test Condition B

Reliability Experiment For Physical

Test Item	Test Condition	Standard Source
Vibration Test	10-55-10HZ, amplitude: 1.5mm, direction: X, Y, Z axes, each axis 2 hours (total 6 hours).	MIL-STD-202G Method 201A
Solder Heat Resistance Test	IR/convection reflow: Peak Temp 250 ± 5°C for 5Sec in air, Through 2 Cycle. Temperature Ramp: +1~4°C/sec; Above 183°C, must keep 90 s - 120 s	MIL-STD-202G Method 210F Test Condition (Reflow)
Solder Ability Test	Soak in 245 °C solder pot of 3Sec, PAD must have 95% above coverage.	J-STD-003B

Typical RoHS Reflow Profile

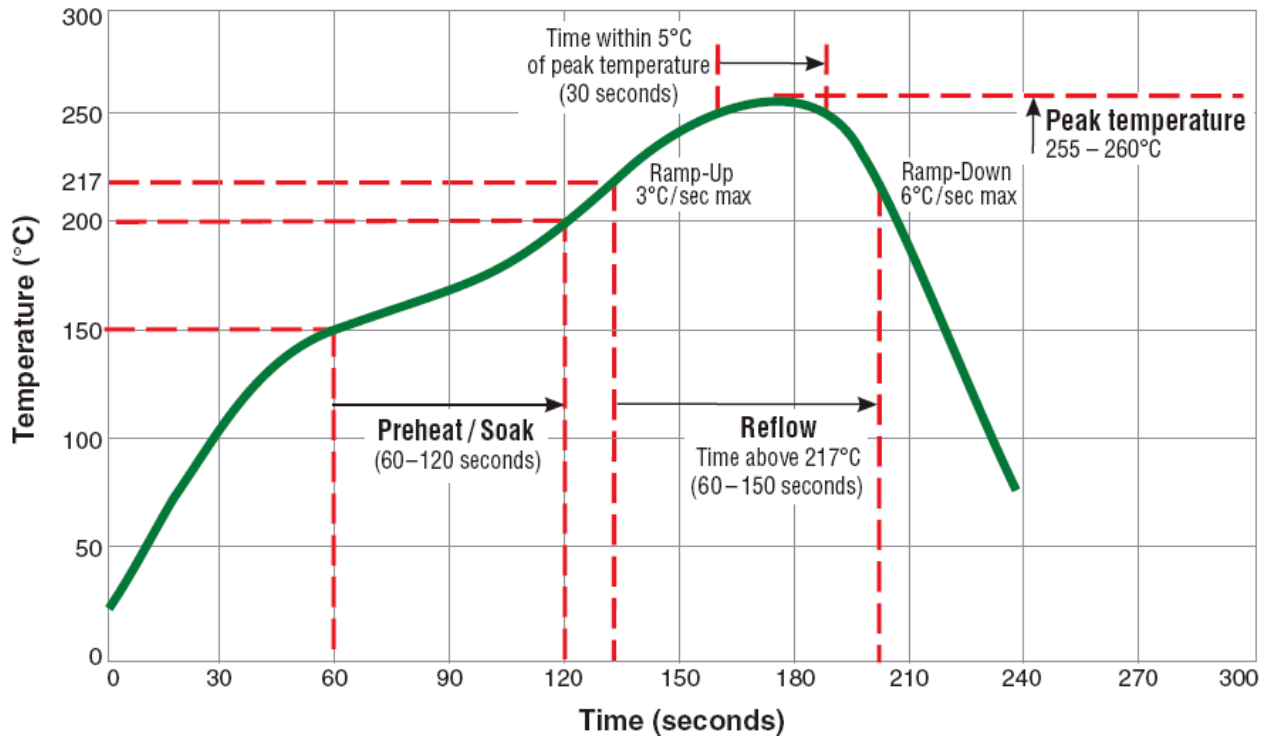

Packaging Specification

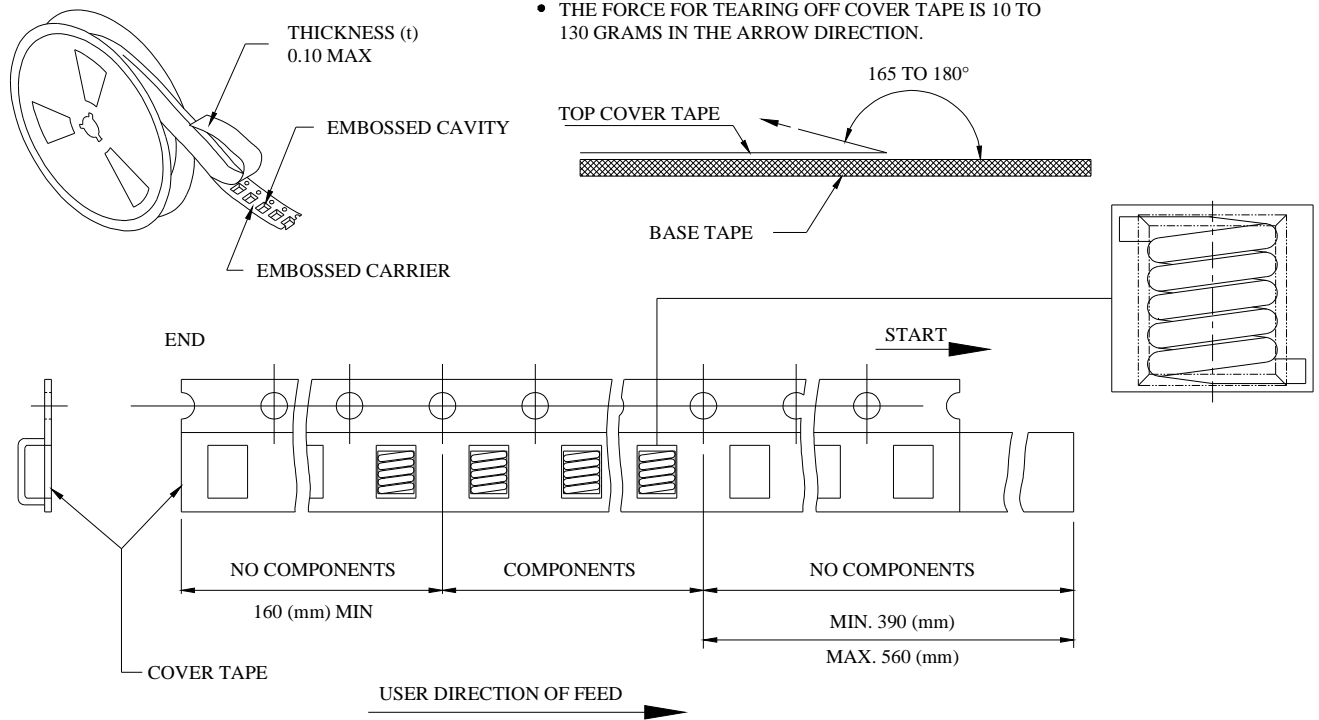

■ CARRIER TAPE REELS (mm)

■ DIMENSIONS OF CARRIER TAPE (mm)

MATERIAL: PLASTIC

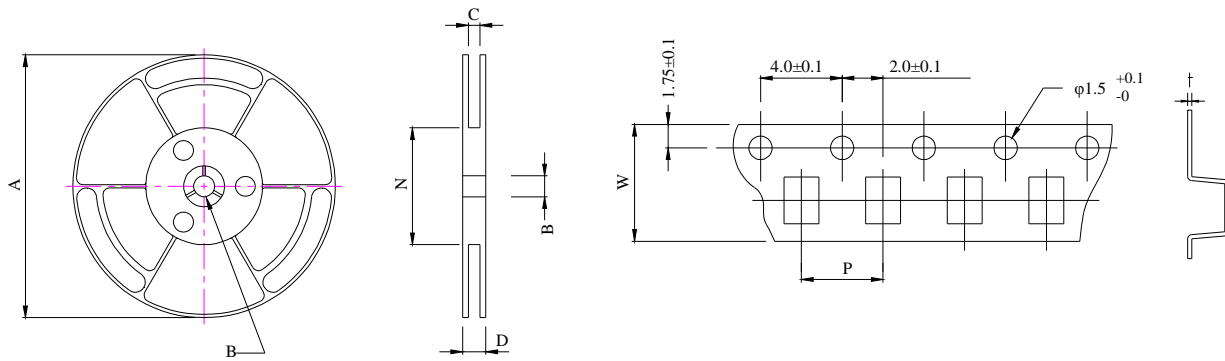

UNIT:mm

291A	A	B	C	D	N	P	W	t
DIM.	178	15	12.5	16.4	75	8	12	0.25
TOL.	±2.0	±0.5	+1.5/-0	+1.5/-0	±2.0	±0.1	±0.2	±0.05

291B	A	B	C	D	N	P	W	t
DIM.	178	15	16.5	20.4	75	8	16	0.25
TOL.	±2.0	±0.5	+1.5/-0	+1.5/-0	±2.0	±0.1	±0.2	±0.05

Quantity per reel : 500 pcs