



# PC33H01 V0

## Product Specification

## Approval Sheet

PC33H01 V0  
Product Specification

RoHS

<b>Product</b>	White SMD LED
<b>Part Number</b>	PC33H01 V0
<b>Issue Date</b>	2014/08/01

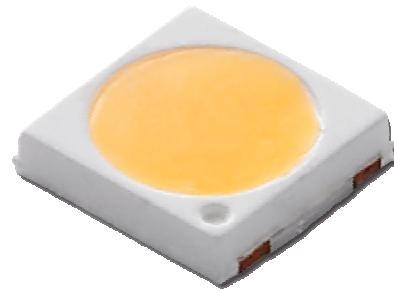

### ■ Feature

- ✓ White SMD LED (L x W x H) of 3.2 x 3.0 x 0.6 mm
- ✓ ANSI binning
- ✓ Dice Technology : InGaN
- ✓ Qualified according to JEDEC moisture sensitivity Level 3
- ✓ Environmental friendly ; RoHS compliance
- ✓ Packing : 3,000 or 1,000 pcs/reel

### ■ Applications

- ✓ Reading lights
- ✓ Security / garden lighting
- ✓ General lighting
- ✓ Indoor and outdoor commercial lighting

## Outline Dimension

PC33H01 V0

Product Specification

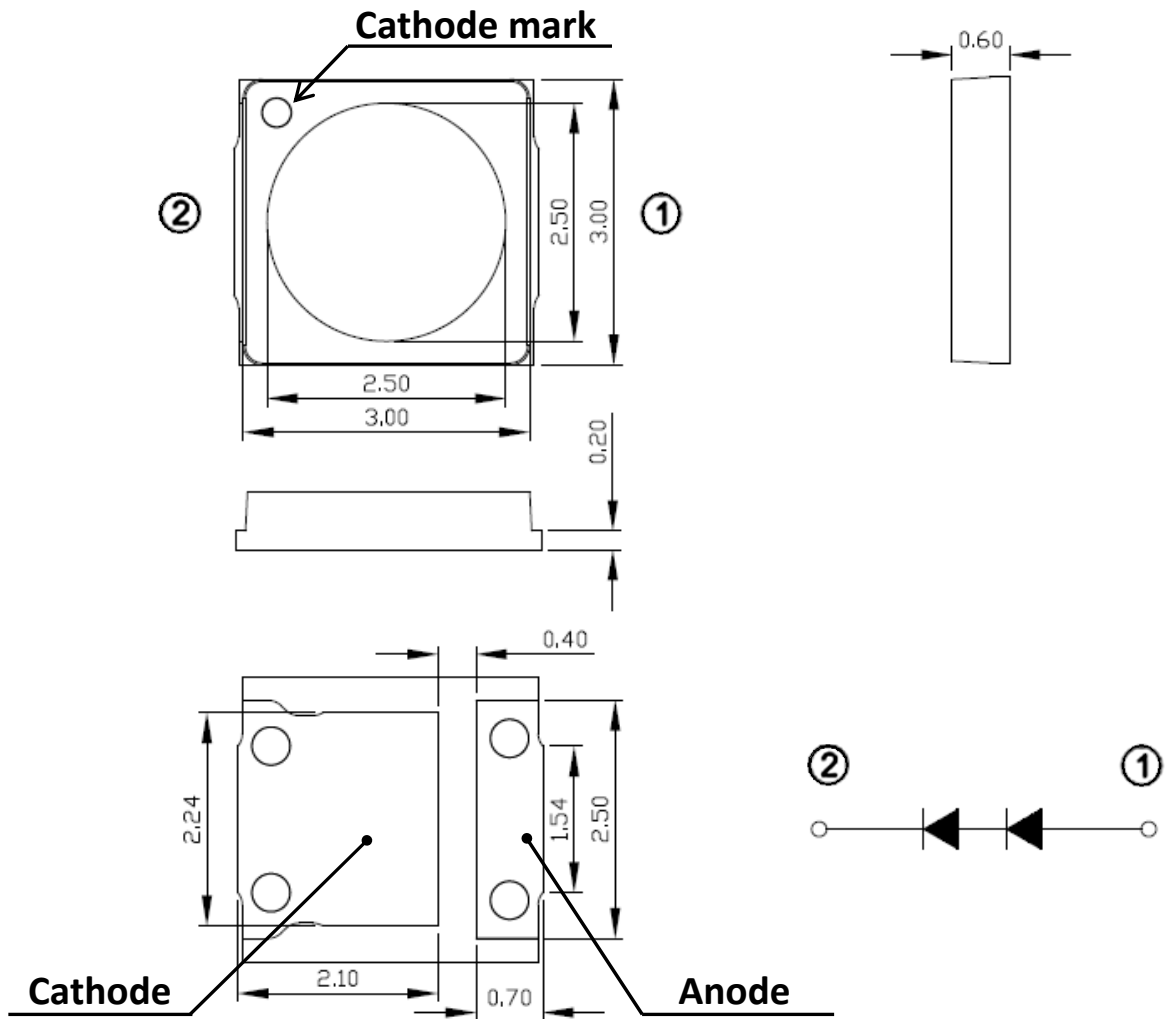

Unit: mm, Tolerance:  $\pm 0.1\text{mm}$

### Recommended Soldering Pad

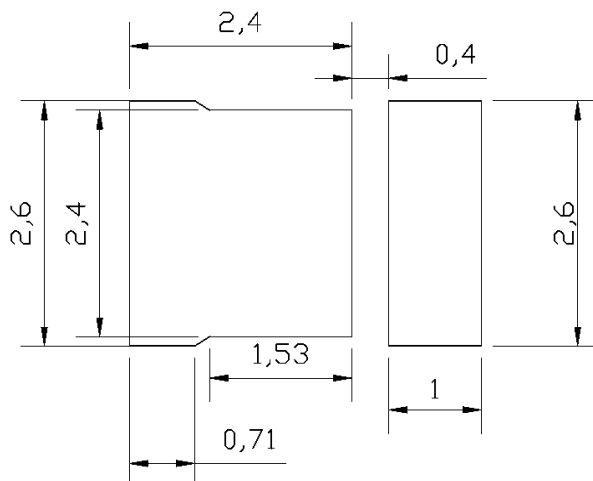

## Performance

PC33H01 V0  
 Product Specification

### ■ Electro-Optical Characteristics (Ta=25°C)

Parameter	Symbol	Condition	Min.	Typ.	Max.	Unit
Forward Voltage <sup>(1)</sup>	$V_F$	$I_F = 150 \text{ mA}$	5.8	6.35	6.8	V
Color Rendering Index <sup>(2)</sup>	Ra		80	-	-	-
View Angle	$\theta$		-	120	-	deg
Thermal Resistance <sup>(3)</sup>	$R_{th}$		-	12	-	°C/W

(1) The Forward Voltage tolerance is  $\pm 0.1V$

(2) The Color Rendering Index tolerance is  $\pm 2$

(3) Thermal resistance is calculated from junction to solder

### ■ Luminous Flux (Ta=25°C)

CCT	Condition	Rank	Typ.	Unit
2600K~3700K	$I_F = 150 \text{ mA}$	VR, VS, VT	110	lm
3700K~7000K		VS, VT, VU	118	

\* The luminous flux tolerance is  $\pm 7\%$

### ■ Absolute Maximum Ratings

Parameter	Symbol	value	Unit
DC Forward Current <sup>(1)</sup>	$I_F$	240	mA
Power Dissipation	$P_D$	1.65	W
Pulse Forward Current <sup>(2)</sup>	$I_{FP}$	480	mA
Storage Temperature	$T_{stg}$	-40 ~ 100	°C
Operating Temperature	$T_{opr}$	-40 ~ 100	°C
Junction Temperature	$T_J$	125	°C
Assembly Temperature	-	260 (max. 10sec)	°C

(1) Proper current rating must be observed to maintain junction temperature below maximum at all time

(2) IFP Condition: Duty 1/10, Pulse within 10msec

**Binning**

PC33H01 V0  
 Product Specification

**Chromaticity Coordinates**

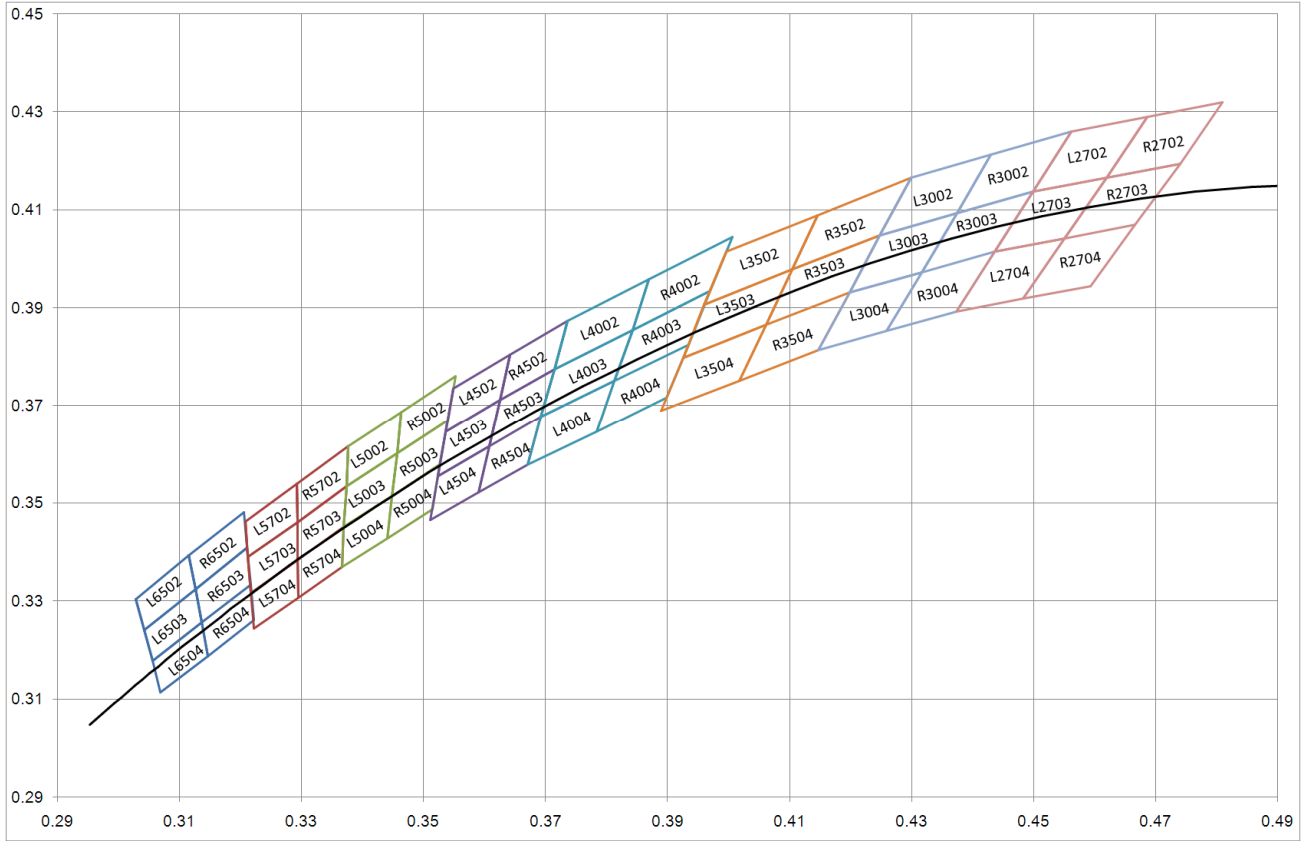

**Bin code definition**

V <sub>F</sub> Rank	Luminous Flux Rank	CIE Rank
Z	VR	R2702

V <sub>F</sub> Rank	Condition	Min.	Max.
Z	I <sub>F</sub> = 150 mA	5.8	6.0
A		6.0	6.2
B		6.2	6.4
C		6.4	6.6
D		6.6	6.8

Luminous Flux Rank	Condition	Min.	Max.
VR	I <sub>F</sub> = 150 mA	87.8	96.6
VS		96.6	106.3
VT		106.3	116.9
VU		116.9	128.6

CCT	CIE Rank	CIE X	CIE Y		CIE X	CIE Y
2700	L2702	0.4562	0.426	R2702	0.4687	0.4289
		0.4499	0.4138		0.462	0.4166
		0.462	0.4166		0.474	0.4194
		0.4687	0.4289		0.481	0.4319
	L2703	0.4499	0.4138	R2703	0.462	0.4166
		0.4436	0.4015		0.4551	0.4042
		0.4551	0.4042		0.4666	0.4069
		0.462	0.4166		0.474	0.4194
	L2704	0.4436	0.4015	R2704	0.4551	0.4042
		0.4373	0.3893		0.4483	0.3919
		0.4483	0.3919		0.4593	0.3944
		0.4551	0.4042		0.4666	0.4069
3000	L3002	0.4299	0.4165	R3002	0.443	0.4212
		0.4248	0.4048		0.4374	0.4093
		0.4374	0.4093		0.4499	0.4138
		0.443	0.4212		0.4562	0.426
	L3003	0.4248	0.4048	R3003	0.4374	0.4093
		0.4198	0.3931		0.4317	0.3973
		0.4317	0.3973		0.4436	0.4015
		0.4374	0.4093		0.4374	0.4093
	L3004	0.4198	0.3931	R3004	0.4317	0.3973
		0.4147	0.3814		0.4259	0.3853
		0.4259	0.3853		0.4373	0.3893
		0.4317	0.3973		0.4436	0.4015
3500	L3502	0.3996	0.4015	R3502	0.4146	0.4089
		0.396	0.3907		0.4104	0.3978

		0.4104	0.3978		0.4248	0.4048		
		0.4146	0.4089		0.4299	0.4165		
	L3503		0.396	0.3907	R3503	0.4104	0.3978	
			0.3925	0.3798		0.4062	0.3865	
			0.4062	0.3865		0.4198	0.3931	
			0.4104	0.3978		0.4248	0.4048	
	L3504		0.3925	0.3798	R3504	0.4062	0.3865	
			0.3889	0.369		0.4017	0.3751	
			0.4017	0.3751		0.4147	0.3814	
			0.4062	0.3865		0.4198	0.3931	
	4000	L4002		0.3736	0.3874	R4002	0.3869	0.3958
				0.3714	0.3775		0.3842	0.3855
0.3842				0.3855	0.397		0.3935	
0.3869				0.3958	0.4006		0.4044	
L4003				0.3714	0.3775	R4003	0.3842	0.3855
				0.3692	0.3677		0.3813	0.3751
				0.3813	0.3751		0.3934	0.3825
				0.3842	0.3855		0.397	0.3935
L4004				0.3692	0.3677	R4004	0.3813	0.3751
				0.367	0.3578		0.3783	0.3646
				0.3783	0.3646		0.3898	0.3716
				0.3813	0.3751		0.3934	0.3825
4500	L4502		0.3548	0.3736	R4502	0.3641	0.3804	
			0.3536	0.3646		0.3625	0.3711	
			0.3625	0.3711		0.3714	0.3775	
			0.3641	0.3804		0.3736	0.3874	
	L4503			0.3536	0.3646	R4503	0.3625	0.3711
				0.3523	0.3555		0.3608	0.3616
				0.3608	0.3616		0.3692	0.3677
				0.3625	0.3711		0.3714	0.3775
	L4504			0.3523	0.3555	R4504	0.3608	0.3616
				0.3511	0.3465		0.359	0.3521

		0.359	0.3521		0.367	0.3578
		0.3608	0.3616		0.3692	0.3677
5000	L5002	0.3376	0.3616	R5002	0.3463	0.3687
		0.3373	0.3534		0.3456	0.3601
		0.3456	0.3601		0.3539	0.3669
		0.3463	0.3687		0.3552	0.376
	L5003	0.3373	0.3534	R5003	0.3456	0.3601
		0.3369	0.3451		0.3448	0.3514
		0.3448	0.3514		0.3526	0.3578
		0.3456	0.3601		0.3539	0.3669
	L5004	0.3369	0.3451	R5004	0.3448	0.3514
		0.3366	0.3369		0.344	0.3428
		0.344	0.3428		0.3514	0.3487
		0.3448	0.3514		0.3526	0.3578
5700	L5702	0.3207	0.3462	R5702	0.3292	0.3539
		0.3212	0.3389		0.3293	0.3461
		0.3293	0.3461		0.3373	0.3534
		0.3292	0.3539		0.3376	0.3616
	L5703	0.3212	0.3389	R5703	0.3293	0.3461
		0.3217	0.3316		0.3293	0.3384
		0.3293	0.3384		0.3369	0.3451
		0.3293	0.3461		0.3373	0.3534
	L5704	0.3217	0.3316	R5704	0.3293	0.3384
		0.3222	0.3243		0.3294	0.3306
		0.3294	0.3306		0.3366	0.3369
		0.3293	0.3384		0.3369	0.3451
6500	L6502	0.3028	0.3304	R6502	0.3115	0.3393
		0.3041	0.324		0.3126	0.3324
		0.3126	0.3324		0.321	0.3408
		0.3115	0.3393		0.3205	0.3481
	L6503	0.3041	0.324	R6503	0.3126	0.3324
		0.3055	0.3177		0.3136	0.3256
		0.3136	0.3256		0.3216	0.3334
		0.3126	0.3324		0.321	0.3408
	L6504	0.3055	0.3177	R6504	0.3136	0.3256
		0.3068	0.3113		0.3146	0.3187



		0.3146	0.3187		0.3221	0.3261
		0.3136	0.3256		0.3216	0.3334

Note:

- (1) Correlated color temperature is derived from the CIE 1931 chromaticity diagram
- (2) CIE measurement tolerance is  $\pm 0.005$
- (3) The luminous flux tolerance is  $\pm 7\%$
- (4) The forward voltage tolerance is  $\pm 0.1V$
- (5) The Color Rendering Index tolerance is  $\pm 2$

## Characteristics

PC33H01 V0  
Product Specification

### Spectrum

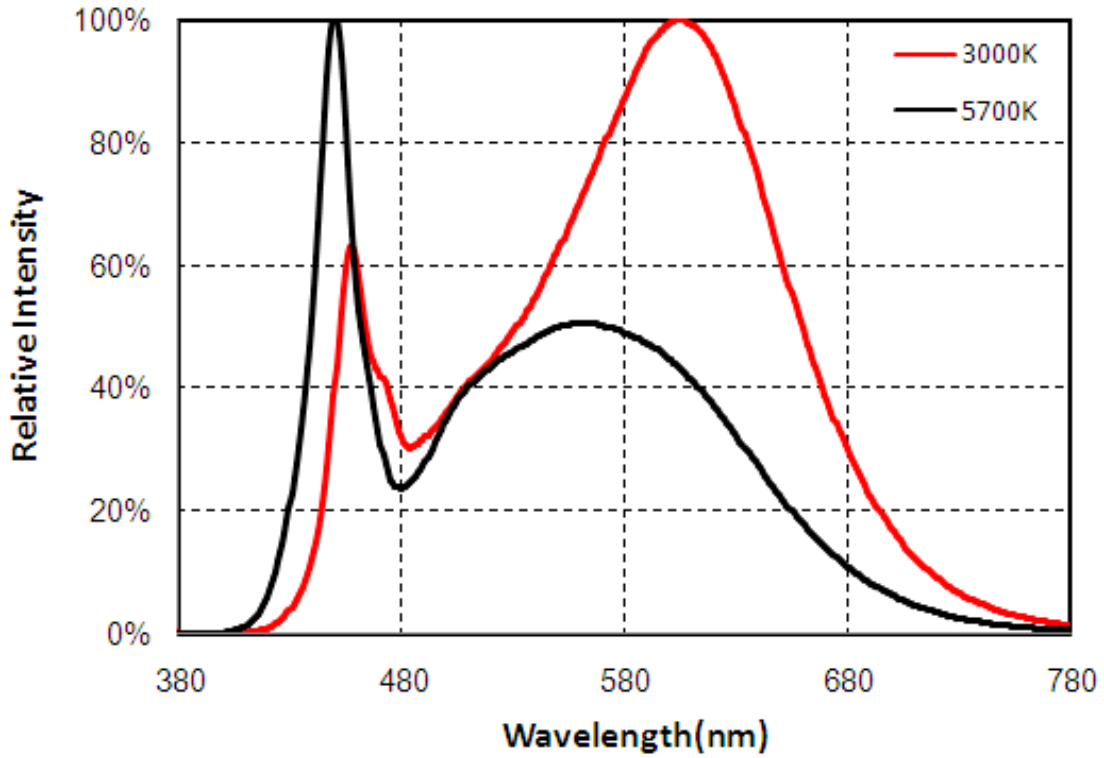

### Radiation Pattern

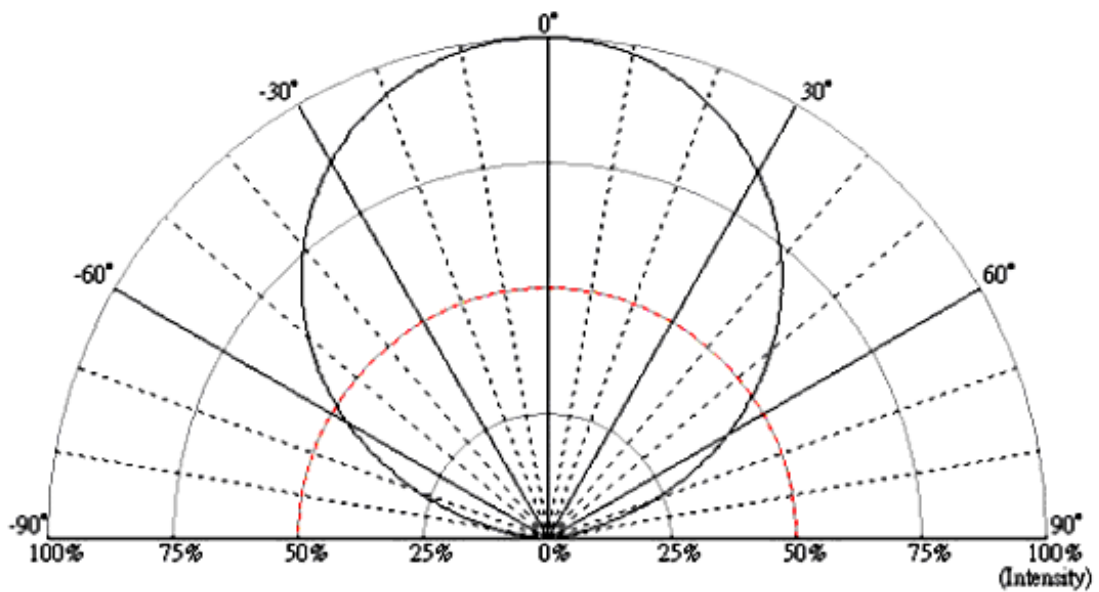

■ **Forward Voltage vs. Forward Current**

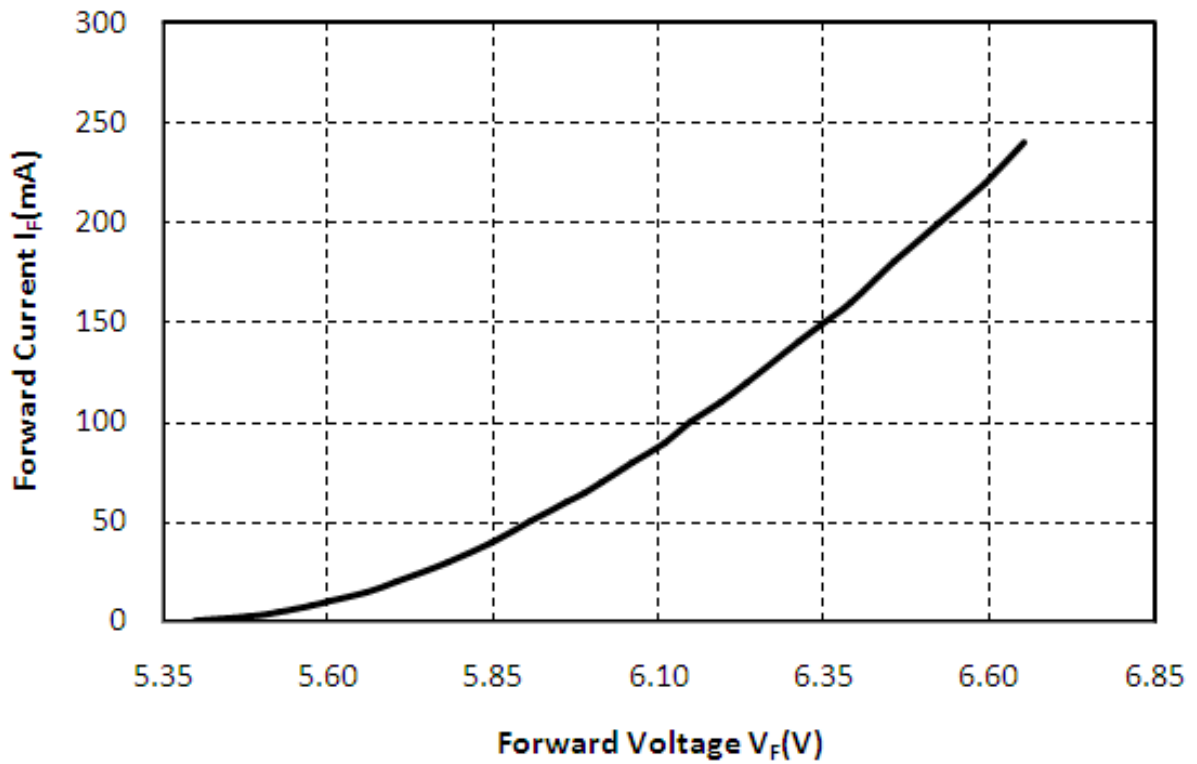

■ **Forward Current vs. Relative Luminosity**

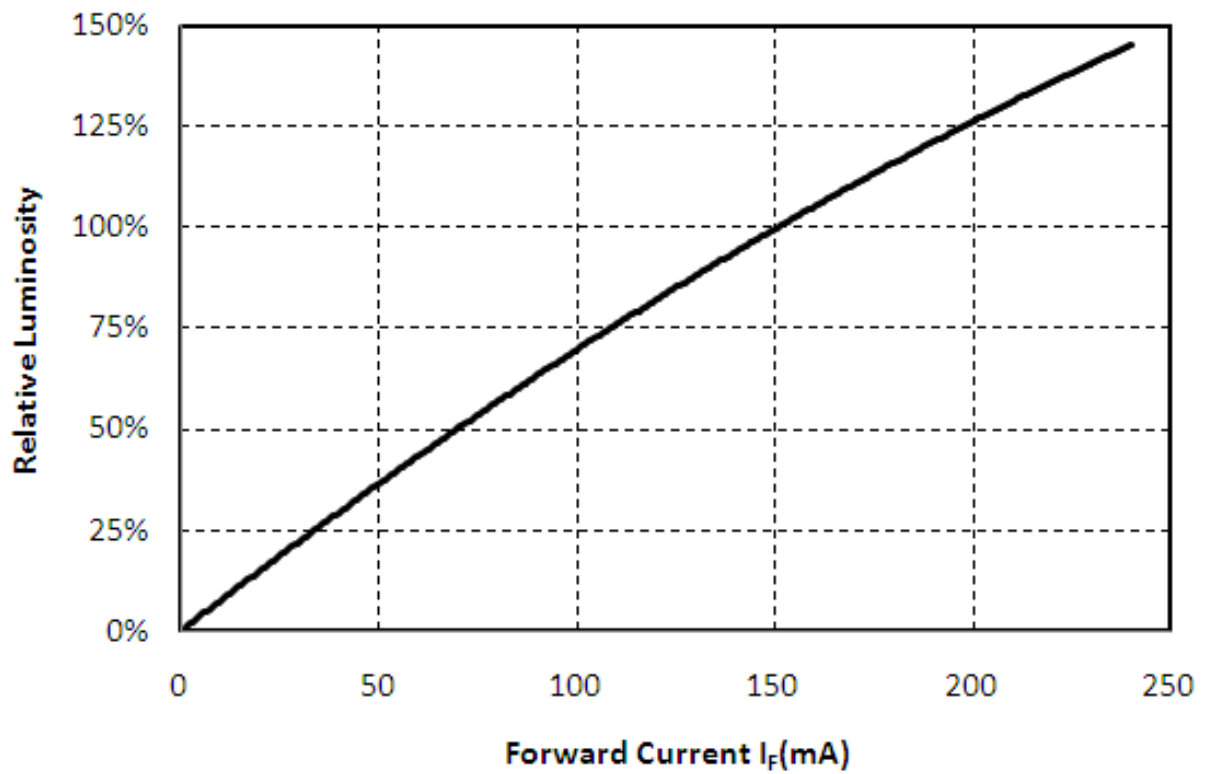

### ■ Forward Current vs. Chromaticity Coordinate

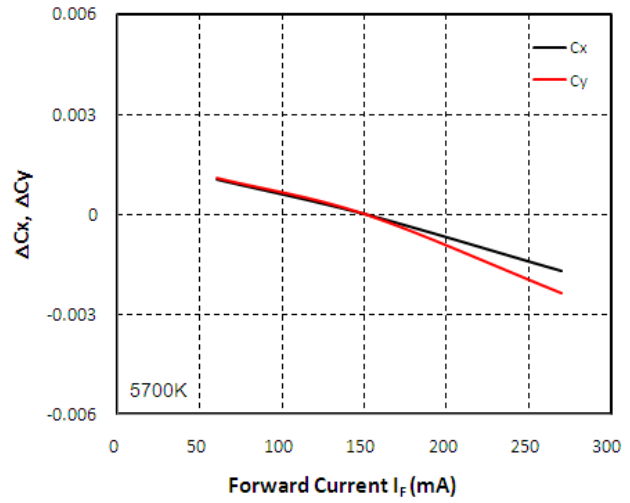
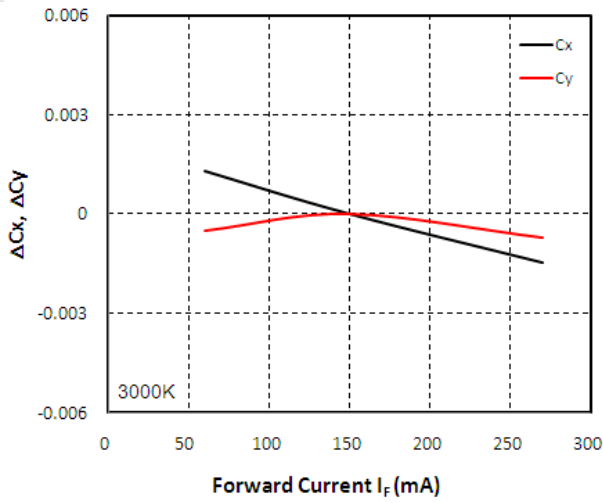

### ■ Relative Forward Voltage vs. Ambient Temperature

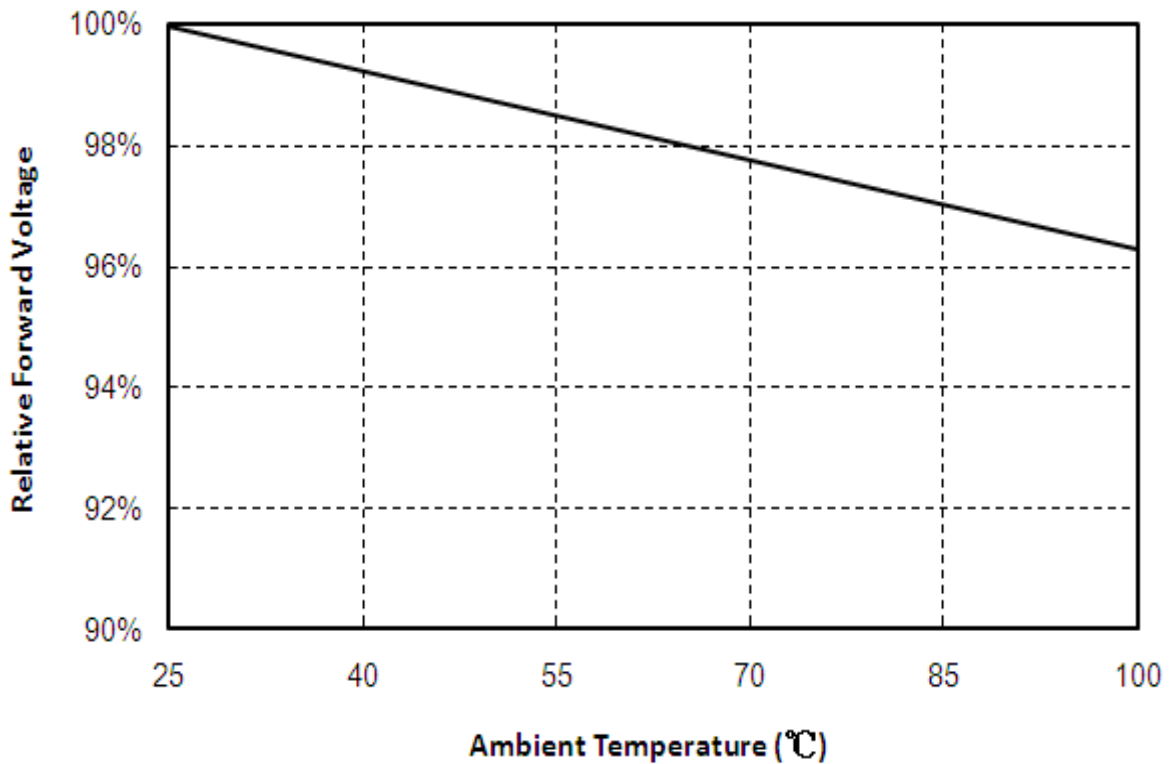

■ **Relative Luminous Intensity vs. Ambient Temperature**

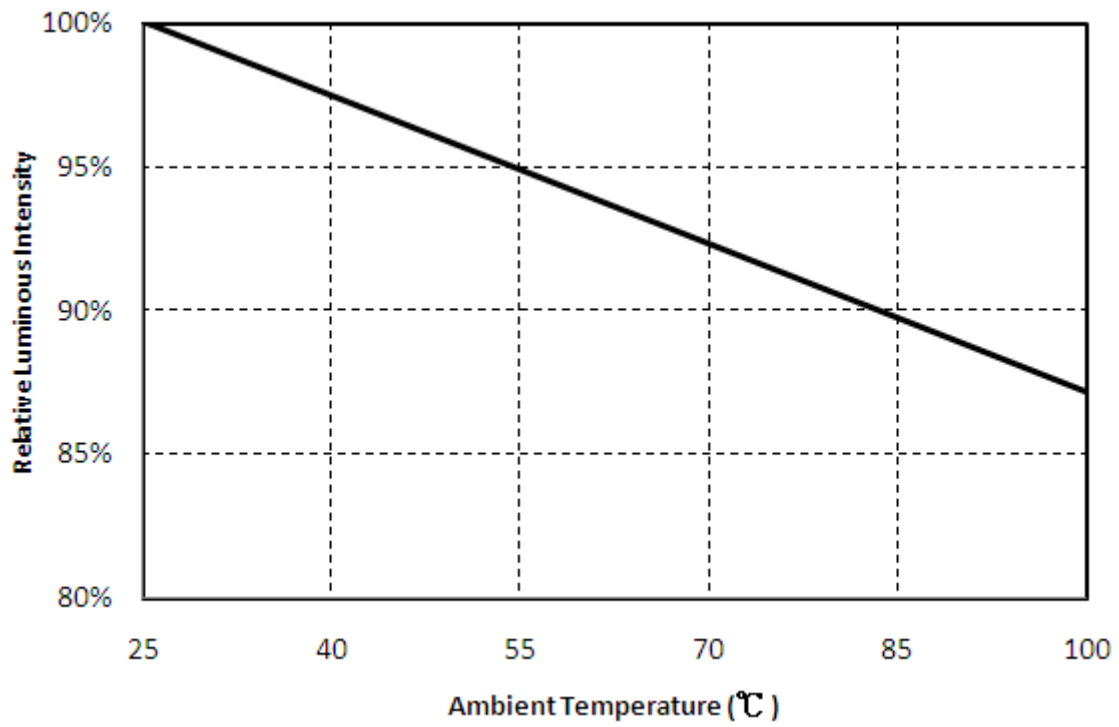

■ **Chromaticity vs. Ambient Temperature**

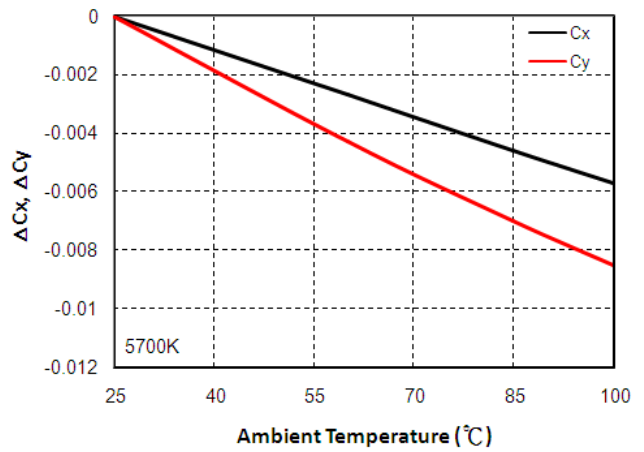
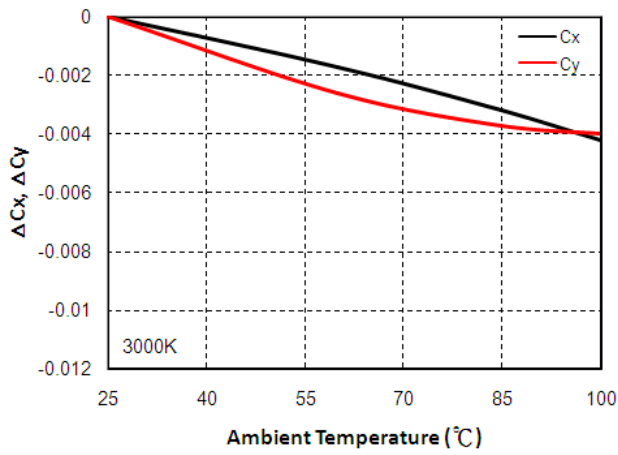

**Reliability**

PC33H01 V0  
 Product Specification

**Reliability test**

Item	Condition	Current	Time/Cycle
Steady State Operating Life of Low Temperature -40°C	-40°C Operating	240mA	1000 Hrs
Steady State Operating Life of High Temperature 60°C	60°C Operating	240Ma	1000 Hrs
Steady State Operating Life of High Temperature 85°C	85°C Operating	240Ma	1000 Hrs
Steady State Operating Life of High Temperature 100°C	100°C Operating	240Ma	1000 Hrs
Low temperature storage -40°C	-40°C Storage	NA	1000 Hrs
High temperature storage 100°C	100°C Storage	NA	1000 Hrs
Steady State Operating Life of High Humidity Heat 60°C 90%	60°C/90% Operating	240Ma	1000 Hrs
Resistance to soldering heat on PCB (JEDEC MSL3)	pre-store@60°C, 60%RH for 52hrs Tsltd max.=260°C 10sec	NA	3 Times
Thermal shock	-40°C/20minr ~5minr ~ 100°C/20min	NA	300 Cycles

**Judgment Criteria**

Item	Symbol	Test Condition	Judgment Criteria
Forward Voltage	Vf	150Ma	$\Delta Vf < 10 \%$
Luminous Flux	Iv	150Ma	$\Delta iv < 30 \%$

## Packing

PC33H01 V0

Product Specification

### Label

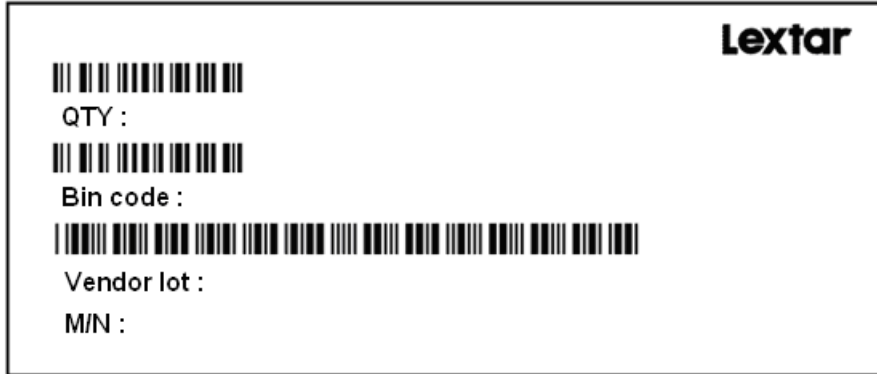

### Carrier Taping

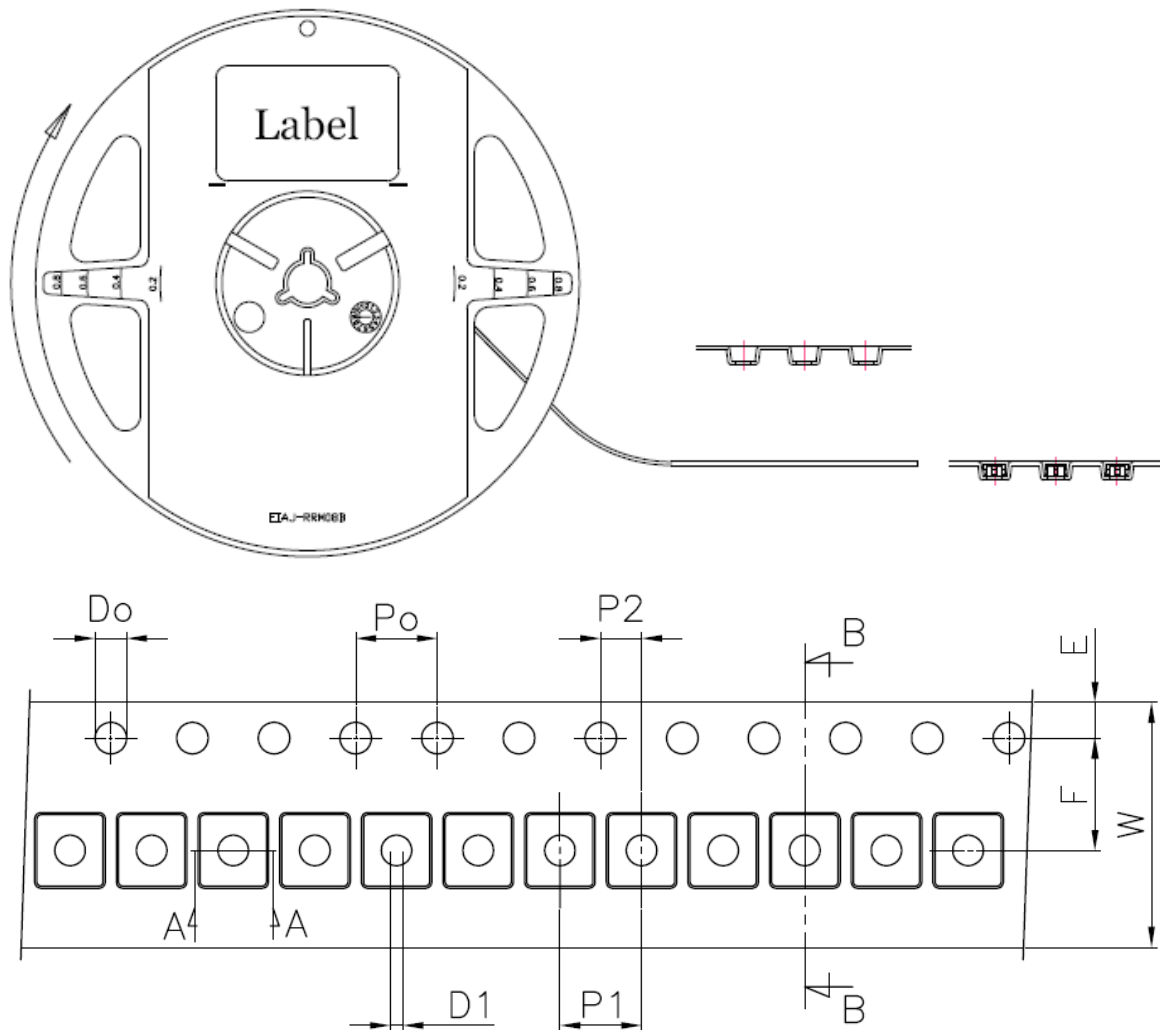

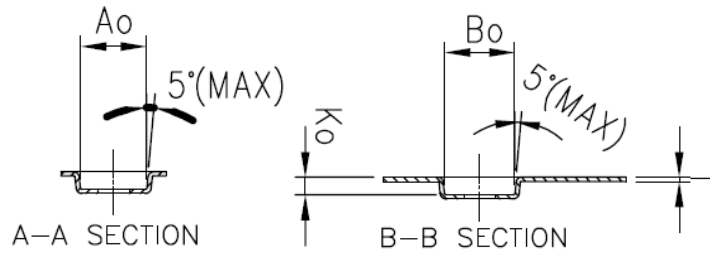

Unit:mm

symbol	Ao	Bo	Ko	Po	P1	P2	T
spec	3.25±0.10	3.50±0.10	0.78±0.10	4.00±0.10	4.00±0.10	2.00±0.05	0.20±0.05
symbol	E	F	Do	D1	W	10Po	
spec	1.75±0.10	5.50±0.05	1.50 <sup>+0.10</sup> <sub>0</sub>	1.50±0.10	12.0±0.30	40.00±0.20	

Notice:

1. 10 Sprocket hole pitch cumulative tolerance is ±0.20mm.
2. Carrier camber shall be not more than 1mm per 100mm through a length of 250mm.
3. Ao & Bo measured on a place in the middle of the corner radii.
4. Ko measured from a place on the inside bottom of the pocket to top surface of carrier.
5. Pocket position relative to sprocket hole measured as true position of pocket, not pocket hole.
6. Surface resistivity  $10^4 \sim 10^8$  ohm/sq.

Shield Bag Taping

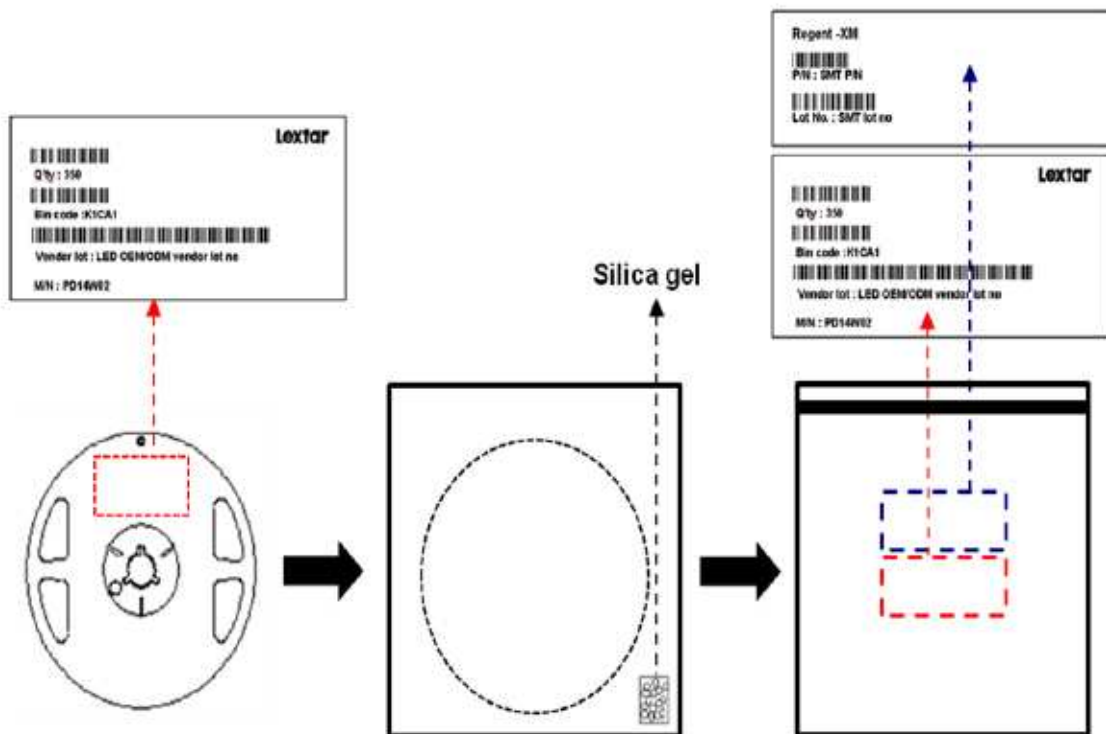



■ **Packing Box**

Type	Large Box		Medium Box		Small Box	
Dimension	541X511X276mm		385X303X260mm		283X235x70mm	
Maximum Reels	7"X12mm Reel	64/R	7"X12mm Reel	21/R	7"X12mm Reel	4/R
Minimum Reels	7"X12mm Reel	32/R	7"X12mm Reel	9/R	7"X12mm Reel	1/R

■ **Small Box**

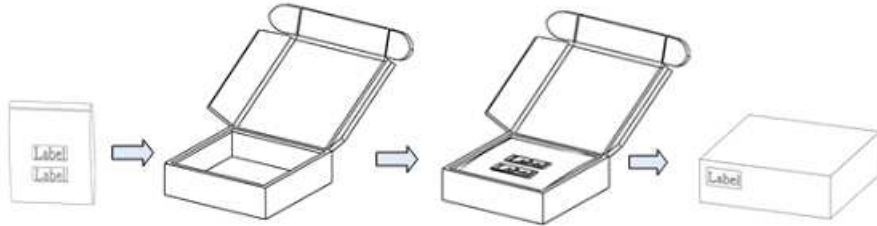

■ **Medium Box**

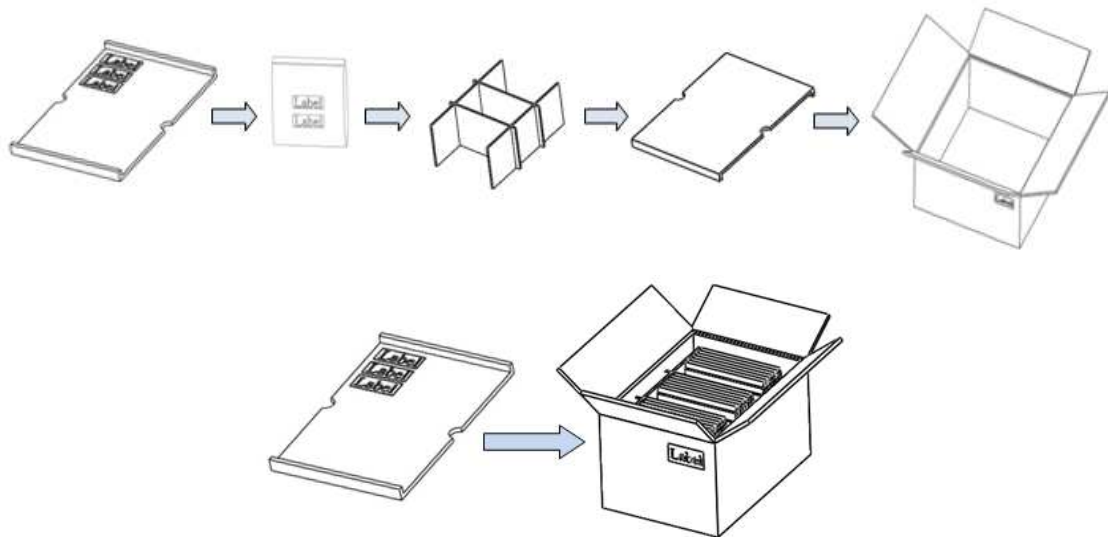

■ **Large Box**

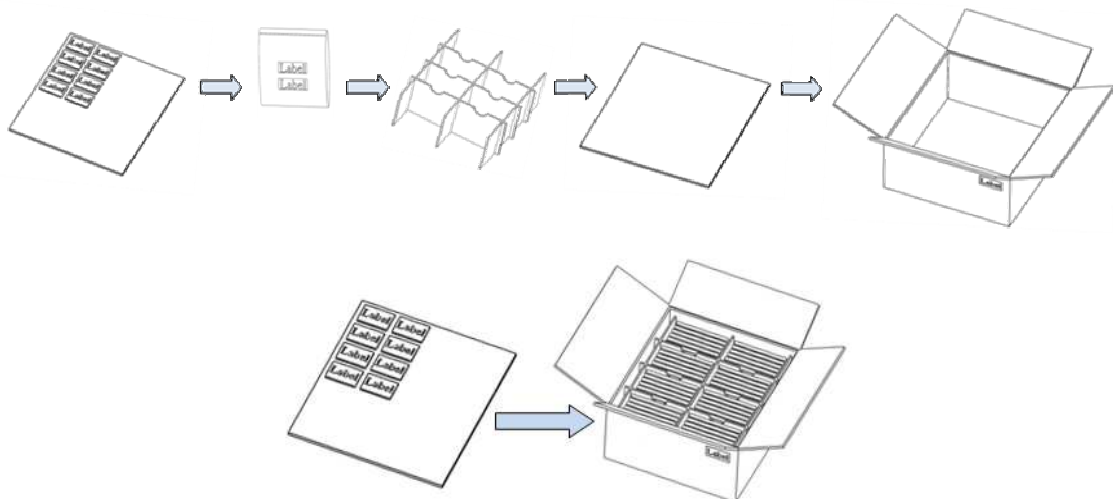

## Precautions

PC33H01 V0

Product Specification

### ■ Safety Precautions

- The LED light output is too strong for human eyes without shield. Prevent eye contact directly more than seconds.
- Ensure operating under maximum rating.

### ■ Storage

- Before opening the package, the LEDs should storage under 30°C, 60% RH.
- After opening the package bag, the LEDs should be keep under 30°C, 60% RH. Recommend to use within 168 hrs. If unused LEDs remain, suggest to store into moisture proof bag or original package bag with moisture absorbent material such as silica gel. Reseal well is necessary.
- If the product exceeded the storage period or the moisture absorbent material faded away, baking treatment should be done by following conditions.  
Bake condition: 60°C, 12hours (One time only).

### ■ Soldering Notice and Conditions

- When soldering LEDs,
- Do not solder/reflow the same LED over two times.
- Recommend soldering conditions:  
Hand soldering: 350 °C max, 3 sec. max.  
Reflow soldering: Pre-heat 150 °C max, 180 sec. max.  
Peak 260 °C max, 10 sec. max.
- Reflow temperature profile as below: (lead-free solder)

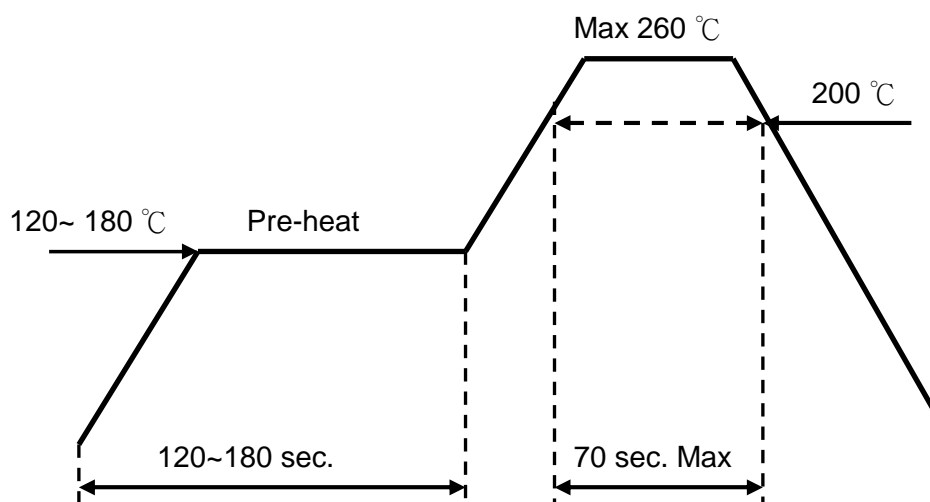

- When soldering, don't put stress on the LEDs
- After LEDs have been soldered, strongly recommend not to repair to keep the LEDs performance.

### ■ **Static Electricity**

- LED package is extremely sensitive to static electricity. It's recommended that anti-electrostatic glove and wrist band is necessary when handling the LEDs. All devices are also be grounded properly as well.
- Protection devices design should be considered in the LED driving circuit.

### ■ **Cleaning**

- If washing is required, recommend to use alcohol as a solvent.
- Recommend to avoid cleaning the LEDs by ultrasonic. If necessary, pre-test the LED is necessary to confirm whether any damage occur after the process.

## Revision History

PC33H01 V0  
Product Specification

Date	Contents	Writer	Approved
2013.11.01	New version	Abigale Wu	Berris Huang
2014.04.01	Update Tolerance	Abigale Wu	Berris Huang
2014.08.01	Create Vf bin "Z" & Update Characteristics	Abigale Wu	Berris Huang

## *Smart Lighting Amazing Life*

Lextar Electronics Corp. is the leading LED (Light Emitting Diode) maker integrating upper stream epitaxial, middle stream chip, and downstream package, SMT and LED lighting applications. Founded in May, 2008, Lextar is a subsidiary of AU Optronics, the leading TFT-LCD and solar PV manufacturer. Lextar's product applications include lighting and LCD backlight. Lextar's manufacturing sites include Hsinchu and Chunan in Taiwan, and Suzhou in China. The company turnover in 2010 is 266 million USD.