



WINSTAR Display Co.,Ltd.
華凌光電股份有限公司



Winstar Display Co., LTD

華凌光電股份有限公司



WEB: <https://www.winstar.com.tw> E-mail: sales@winstar.com.tw

SPECIFICATION

CUSTOMER : _____

MODULE NO.: WF1560ATWFA5LENO#

<p>APPROVED BY:</p> <p>(FOR CUSTOMER USE ONLY)</p>	<p>PCB VERSION: _____</p> <p>DATA: _____</p>
---	--

SALES BY	APPROVED BY	CHECKED BY	PREPARED BY
			葉虹蘭
ISSUED DATE: 2025/01/14			

Precaution in use of TFT module: <https://www.winstar.com.tw/technology/download/declaration.html>

MODLE NO :

RECORDS OF REVISION	DOC. FIRST ISSUE
----------------------------	-------------------------

VERSION	DATE	REVISED PAGE NO.	SUMMARY
0	2023/11/08		First issue
A	2024/02/15		Add Inspection Specification Modify Summary and Interface
B	2025/01/14		Modify Reliability

WINSTAR DISPLAY CO., LTD.

Contents

1.Module Classification Information

2.Summary

3.General Specifications

4.Absolute Maximum Ratings

5.Electrical Characteristics

6.Pixel Format Image

7.Interface Timings

8.Power ON/OFF Sequence

9.Optical Characteristics

10.Interface

11.Block Diagram

12.Reliability

13.Contour Drawing

14.Inspection Specification

15.Other

1.Module Classification Information

W F 1560 A T W F A5 L E N 0 #
 ① ② ③ ④ ⑤ ⑥ ⑦ ⑧ ⑨ ⑩ ⑪ ⑫ ⑬

①	Brand : WINSTAR DISPLAY CORPORATION												
②	Display Type : F→TFT Type, J→Custom TFT												
③	Display Size : 15.6" TFT												
④	Model serials no.												
⑤	Backlight Type :	F→CCFL, White S→LED, High Light White					T→LED, White Z→Nichia LED, White						
⑥	LCD Polarize Type/ Temperature range/ Gray Scale Inversion Direction	A→Transmissive, N.T, IPS TFT C→Transmissive, N. T, 6:00 ; F→Transmissive, N.T,12:00 ; I→Transmissive, W. T, 6:00 K→Transflective, W.T,12:00 L→Transmissive, W.T,12:00 N→Transmissive, Super W.T, 6:00					Q→Transmissive, Super W.T, 12:00 R→Transmissive, Super W.T, O-TFT V→Transmissive, Super W.T, VA TFT W→Transmissive, Super W.T, IPS TFT X→Transmissive, W.T, VA TFT Y→Transmissive, W.T, IPS TFT Z→Transmissive, W.T, O-TFT						
⑦	A : TFT LCD B : TFT+SCREW HOLES+CONTROL BOARD C : TFT+ SCREW HOLES +A/D BOARD D : TFT+ SCREW HOLES +A/D BOARD+CONTROL BOARD E : TFT+ SCREW HOLES +POWER BOARD					F : TFT+CONTROL BOARD G : TFT+ SCREW HOLES H : TFT+D/V BOARD I : TFT+ SCREW HOLES +D/V BOARD J : TFT+POWER BD							
⑧	Resolution:												
	M	1024768	N	128128	P	1280800	Q	480800	R	640320	S	480128	
	T	800320	U	8001280	V	176220	W	1280398	X	1024250	Y	1920720	
	A5	19201080	A6	480480	A7	10801920	A8	135240	A9	480640	B2	122250	
	B3	340800	B4	2801424	B5	12001920	B6	4801280	B7	800800	B8	40160	
⑨	D: Digital		L:LVDS			M:MIPI			E:eDP				
⑩	Interface:												
	N	Without control board			A	8Bit	B	16Bit		E	eDP	H	HDMI
	I	I2C Interface			R	RS232	S	SPI Interface		U	USB		
⑪	TS:												
	N	Without TS			T	Resistive touch panel			C	Capacitive touch panel (G-F-F)			
	G	Capacitive touch panel (G-G)					C1	Capacitive touch panel (G-F-F)+OCA					
	C2	Capacitive touch panel (G-F-F)+OCR					G1	Capacitive touch panel (G-G)+OCA					
	G2	Capacitive touch panel (G-G)+OCR					B	CTP+GG+USB					
⑫	Version:	X:Raspberry pi				V: Raspberry pi 3B+							
⑬	Special Code	#:Fit in with ROHS directive regulations											

WINSTAR DISPLAY Co., Ltd.

2.Summary

WF1560A is a 15.6" TFT Liquid Crystal Display module with WLED Backlight unit and 30 pins eDP interface (The original TFT panel is 2ch-LVDS). This module supports 1920 x 1080 FHD AAS mode and can display 16,777,216 colors (16.7M).

WINSTAR DISPLAY Co., Ltd.

3. General Specifications

Item	Dimension	Unit
Size	15.6	inch
Dot Matrix	1920 x RGB x 1080	dots
Module dimension	363.8(W) x 215.9(H)x 20.8 (D)	mm
Active area	344.16 x 193.59	mm
Pixel pitch	0.17925 (H) x 0.17925 (V)	mm
LCD type	TFT, Normally Black, Transmissive	
Viewing Angle	89/89/89/89	
Backlight Type	LED, Normally White	
Controller IC	CH7513A-BFI	
TFT Interface	eDP	
With /Without TP	Without TP	
Surface	Anti-Glare	

*Color tone slight changed by temperature and driving voltage.

4. Absolute Maximum Ratings

Item	Symbol	Min	Typ	Max	Unit
Operating Temperature	TOP	-30	—	+85	°C
Storage Temperature	TST	-40	—	+90	°C

Note: Device is subject to be damaged permanently if stresses beyond those absolute maximum ratings listed above

1. Temp. $\leq 60^{\circ}\text{C}$, 90% RH MAX. Temp. $> 60^{\circ}\text{C}$, Absolute humidity shall be less than 90% RH at 60°C

WINSTAR DISPLAY Co., Ltd.

5. Electrical Characteristics

5.1. Operating conditions:

Item	Symbol	Min	Typ	Max	Unit	Remark
Supply Voltage For LCM	P1 VDD	4.7	5	5.3	V	-
Supply Current For LCM	P1 IDD	—	900	1350	mA	Note 1,2

5.2. Backlight conditions:

Item	Symbol	Min	Typ	Max	Unit	Remark
Supply Voltage For Back Light	P2 VDD	11.5	12	12.5	V	-
Supply Current For Back Light	P2 IDD	—	1000	1500	mA	Note 1,2
LED life time	—	—	50,000	—	Hr	Note 3

Note 1 : This value is test for P1 VDD=5.0V , P2 VDD =12.0V , Ta=25°C only

Note 2 : Please make sure to support enough current.

Note 3: The "LED life time" is defined as the module brightness decrease to 50% original brightness at Ta=25°C

5.3. Signal Electrical Characteristics

Input signals shall be low or High-impedance state when P1 VDD is off.

It is recommended to refer the specifications of VESA Display Port Standard V1.2 in detail.

Table 1 Display Port Main Link

Parameter	Description	Min.	Typ.	Max.	Unit
V_{CM}	Differentia Common Mode Voltage	0	-	2.0	V
$V_{DIFF P-P}$ Level 1	Differential Peak to Peak Voltage Level 1	0.34	0.40	0.46	V
$V_{DIFF P-P}$ Level 2	Differential Peak to Peak Voltage Level 2	0.51	0.60	0.68	V
$V_{DIFF P-P}$ Level 3	Differential Peak to Peak Voltage Level 3	0.69	0.80	0.92	V
$V_{DIFF P-P}$ Level 4	Differential Peak to Peak Voltage Level 4	1.02	1.20	1.38	V

Note: Follow as VESA display port standard V1.2 at both 1.62 and 2.7Gbps link rates.

Figure 2 Display Port Main Link Signal

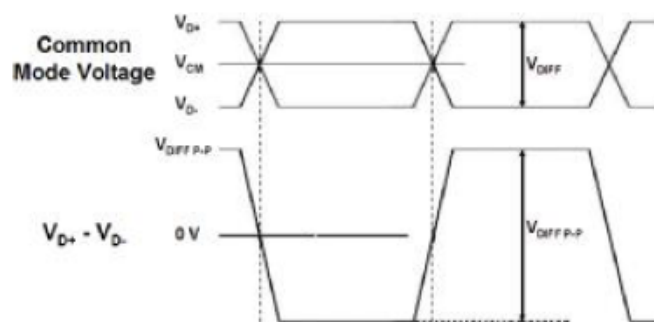

Figure 3 Display Port AUX_CH Signal

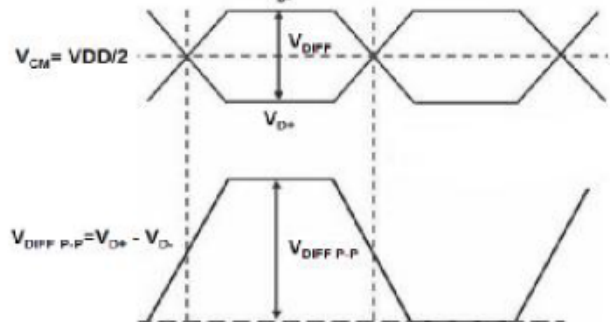

Table 2 Display Port AUX_CH

Parameter	Description	Min.	Typ.	Max.	Unit
V_{CM}	Differentia Common Mode Voltage	0	VDD/2	2	V
$V_{DIFF P-P}$	Differential Peak to Peak Voltage	0.39	-	1.38	V

Note: Follow as VESA display port standard V1.2.

Table 3 Display Port VHPD

Parameter	Description	Min.	Typ.	Max.	Unit
V _{HPD}	HPD Voltage	2.25		3.60	V

Note: Follow as VESA display port standard V1.2

Figure 4 Display Port Interface Power Up/Down Sequence, Normal System Operation

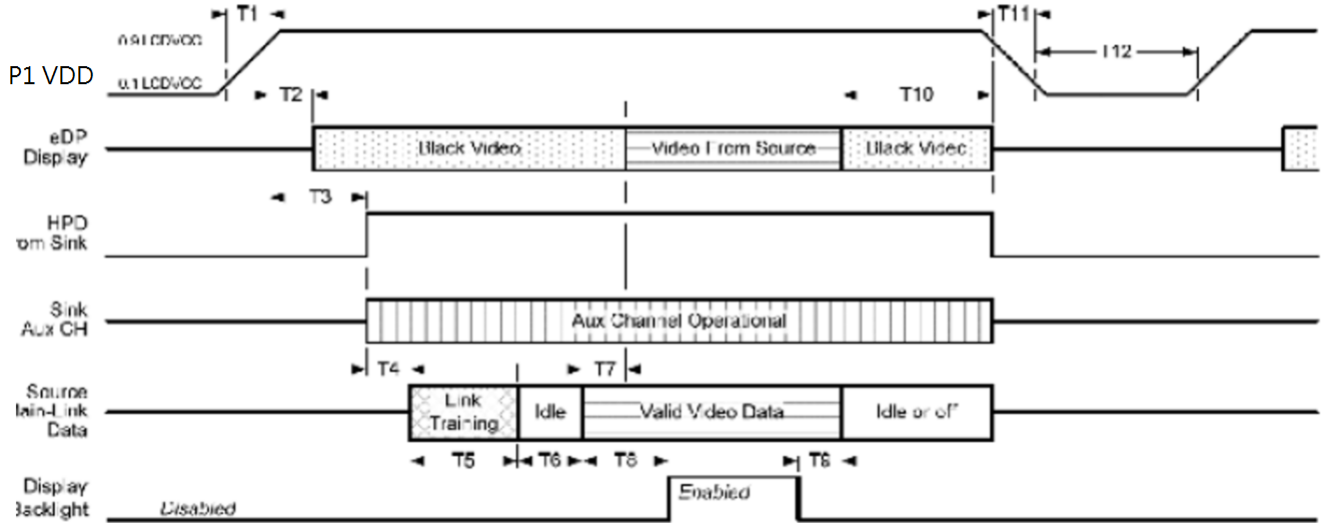

Figure 5 Display Port Interface Power Up/Down Sequence, Aux Channel Transaction Only

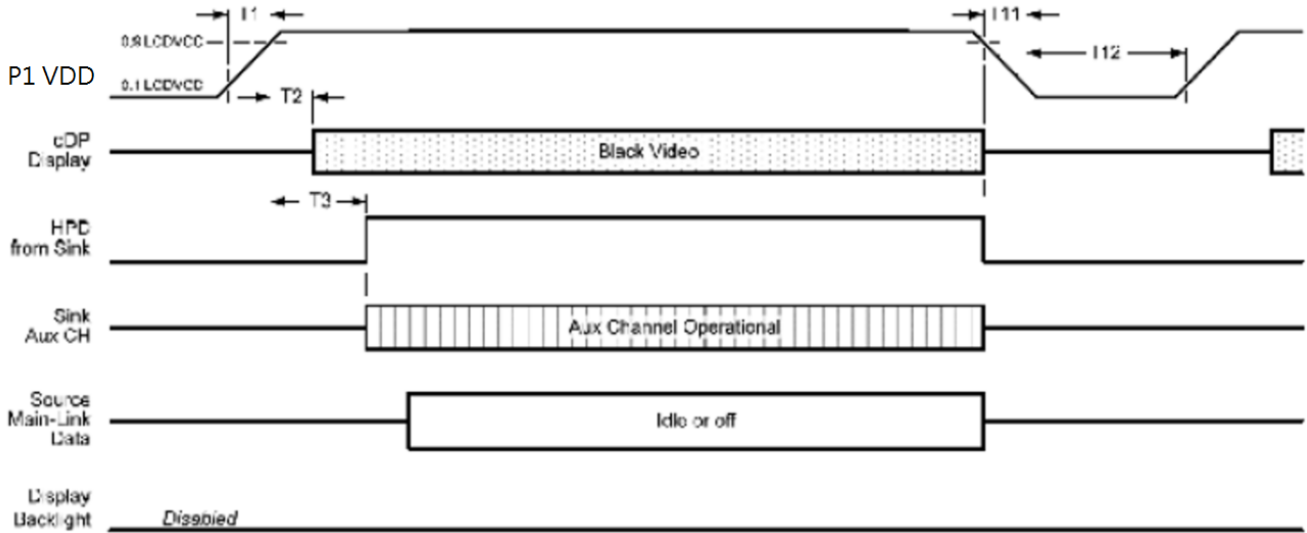

Table 4 eDP Panel Power Sequence Timing Parameters

Timing Parameter	Description	Reqd. By	Limits		Notes
			Min.	Max.	
T1	Power rail rise time, 10% to 90%	Source	0.5ms	10ms	-
T2	Delay from LCD VCC to black video generation	Sink	0ms	200ms	Prevents display noise until valid video data is received from the Source.(see note 1 below)
T3	Delay from LCD VCC to HPD high	Sink	0ms	200ms	Sink Aux Channel must be operational upon HPD high.
T4	Delay from HPD high to link training initialization	Source	-	-	Allows for Source to read Link capability and initialize.
T5	Link training duration	Source	-	-	Dependant on Source link training protocol.
T6	Link idle	Source	-	-	Min accounts for required BS-Idle pattern. Max allows for Source frame synchronization.
T7	Delay from valid video data from Source to video on display	Sink	0ms	50ms	Max allows Sink validate video data and timing.
T8	Delay from valid video from Source to backlight enable	Source	-	-	Source must assure display video is stable.
T9	Delay from backlight disable to end of valid video data	Source	-	-	Source must assure backlight is no longer illuminated.(see note 1 below)
T10	Delay from end of valid video data from Source to power off	Source	0ms	500ms	-
T11	Power rail fall time, 90% to 10%	Source	-	10ms	-
T12	Power off time	Source	500ms	-	-

Note 1: The Sink must include the ability to generate black video autonomously. The Sink must automatically enable black video under the following conditions:

- Upon P1 VDD power-on (within T2 max)
- When the “NoVideoStream_Flag” (VB-ID Bit 3) is received from the Source (at the end of T9)
- When no Main Link data, or invalid video data, is received from the Source. Black video must be displayed within 50ms (max) from the start of either condition. Video data can be deemed invalid based on MSA and timing information, for example.

Note 2: The Sink may implement the ability to disable the black video function, as described in Notes 1, above, for system development and debugging purposes.

Note 3: The Sink must support Aux Channel polling by the Source immediately following P1 VDD power-on without causing damage to the Sink device (the Source can re-try if the Sink is not ready).

The Sink must be able to respond to an Aux Channel transaction with the time specified within T3max.

WINSTAR DISPLAY CO., LTD.

6.Pixel Format Image

Figure 6 shows the relationship of the input signals and LCD pixels format image.

Figure 6 Pixel Format

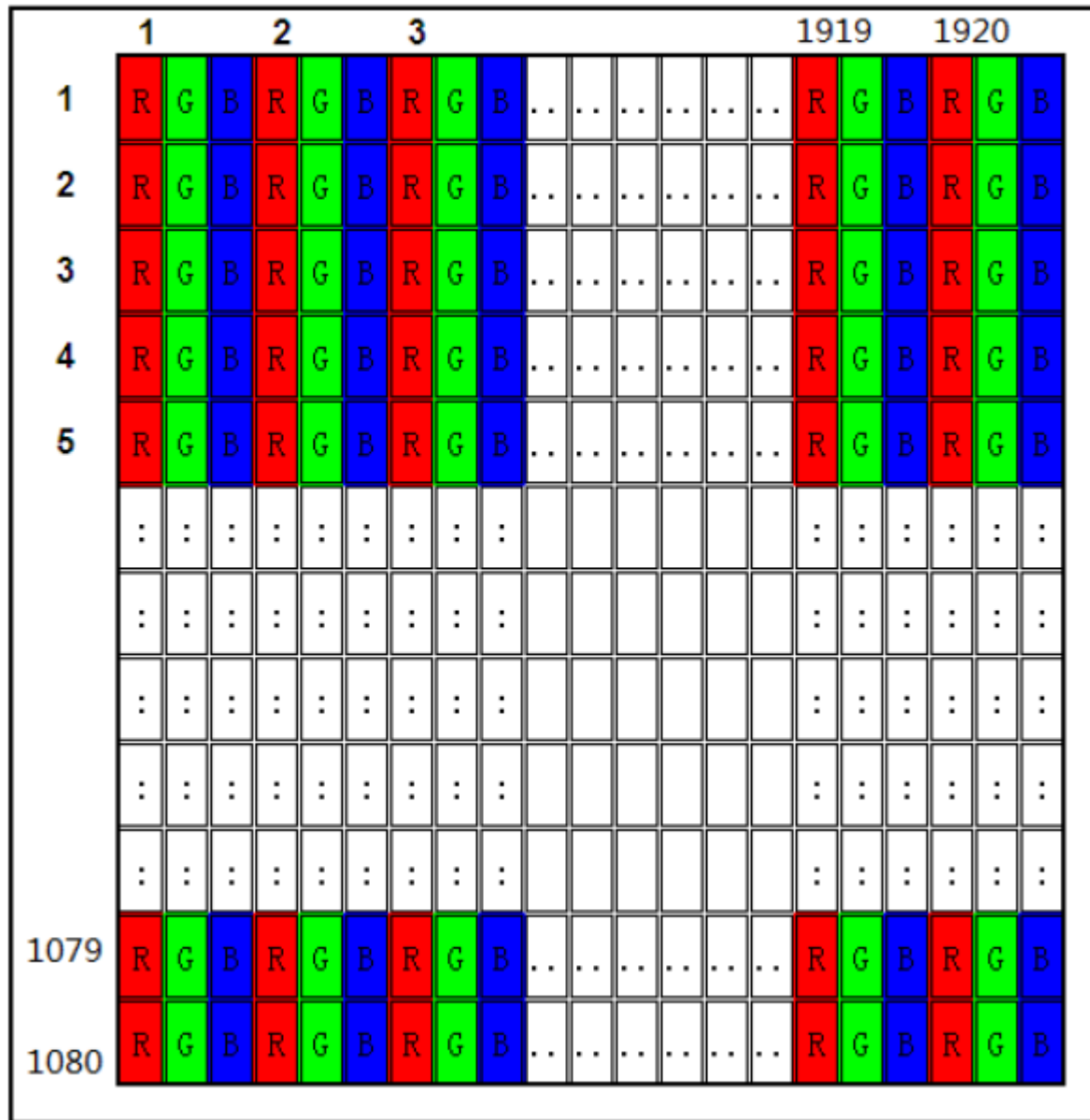

7. Interface Timings

7.1. Timing Characteristics

Basically, interface timings should match the 1920 x 1080 /60Hz manufacturing guide line timing.

Table Interface Timings

The input signal timing (2ch-LVDS) specifications are shown as the following table and timing diagram.

Signal	Item	Symbol	Min.	Typ.	Max.	Unit	Note
2ch-LVDS Clock	Frequency	F _c	60	70.93	75	MHz	-
	Period	T _c		14.1		ns	-
	Input cycle to cycle jitter	T _{rd}	-0.02*T _c		0.02*T _c	ns	-
	Input clock to data skew	TLVCCS	-0.02*T _c		0.02*T _c	ns	-
	Spread spectrum modulation range	F _{ckin_mod}	FC*98%		FC*102%	MHz	-
	Spread spectrum modulation frequency	F _{SSM}			200	KHz	
Vertical Display Term	Frame Rate	Fr	50	60	60	Hz	T _v =T _v d+T _v b
	Total	T _v	1090	1110	1130	Th	-
	Active Display	T _v d	1080	1080	1080	Th	-
	Blank	T _v b	T _v -T _v d	30	T _v -T _v d	Th	-
Horizontal Display Term	Total	T _h	1050	1065	1075	T _c	T _h =T _h d+T _h b
	Active Display	T _h d	960	960	960	T _c	-
	Blank	T _h b	T _h -T _h d	105	T _h -T _h d	T _c	-

Note (1) Because this module is operated by DE only mode, Hsync and Vsync input signals are ignored.

Note (2) The T_v(T_vd+T_vb) must be integer, otherwise, this module would operate abnormally.

INPUT SIGNAL TIMING DIAGRAM

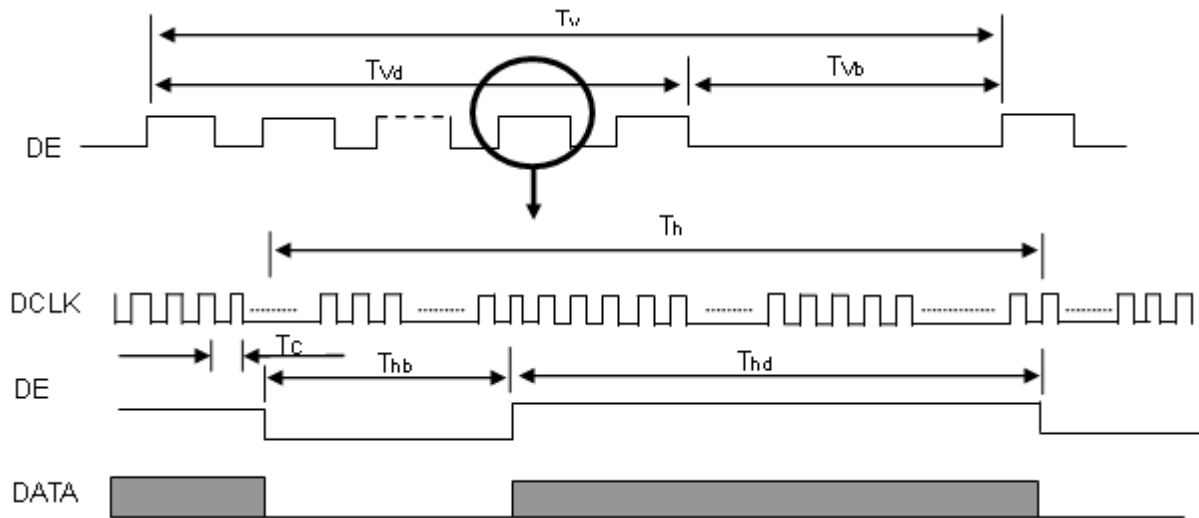

Note (3) The input clock cycle-to-cycle jitter is defined as below figures. $Trcl = |T1 - Tl|$

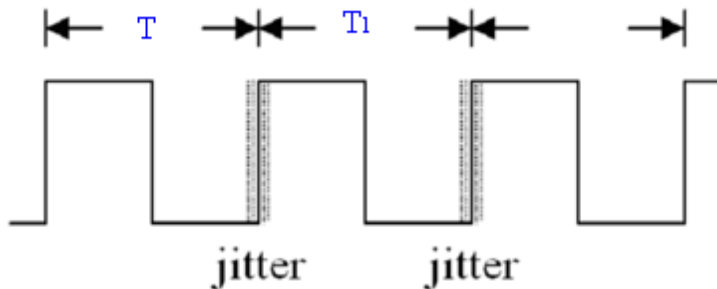

Note (4) Input Clock to data skew is defined as below figures

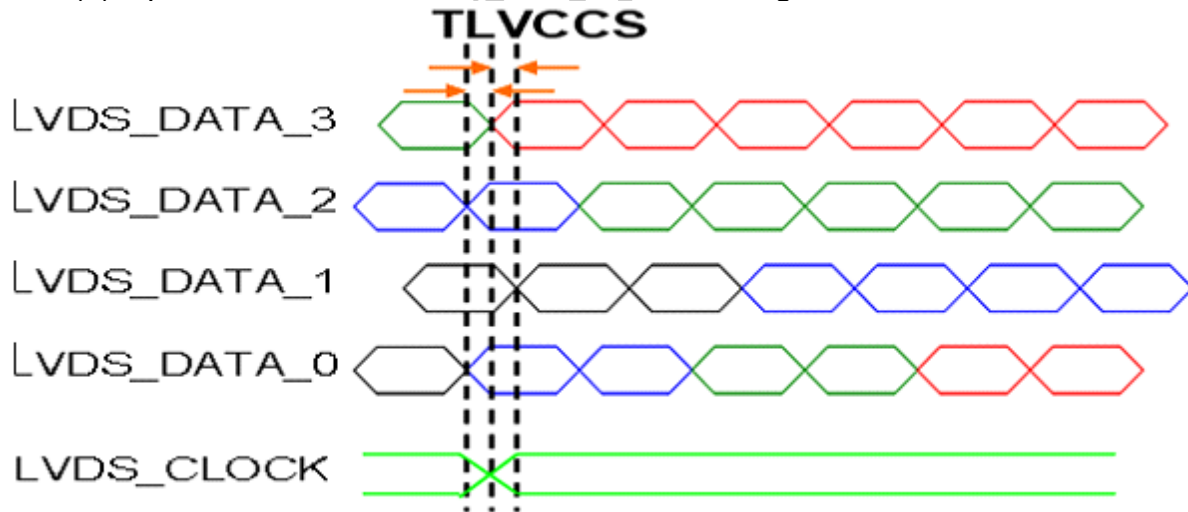

Note (5) The SSCG (Spread spectrum clock generator) is defined as below figures

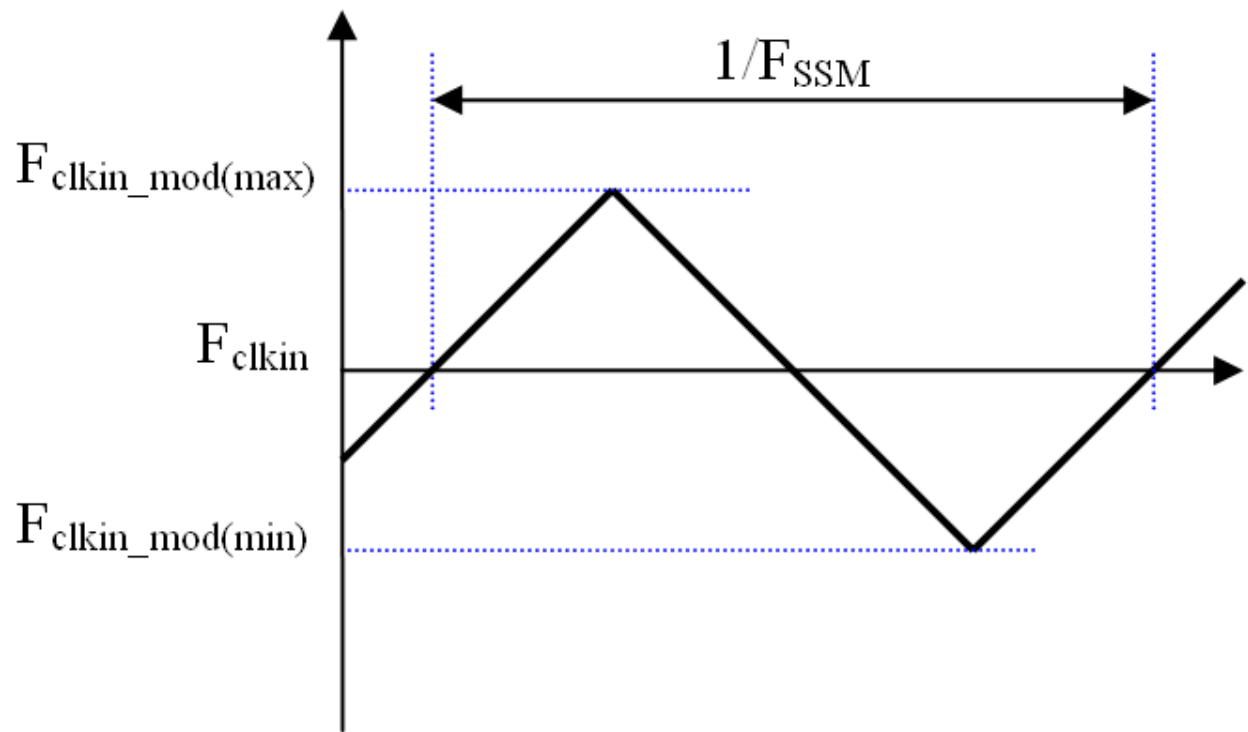

WINSTAR DISPLAY

8. Power ON/OFF Sequence

P1/P2 VDD power on/off sequence is as follows. Interface signals are also shown in the chart. Signals from any system shall be Hi-Z state or low level when P1 VDD is off.

Figure 8-1 Power Sequence

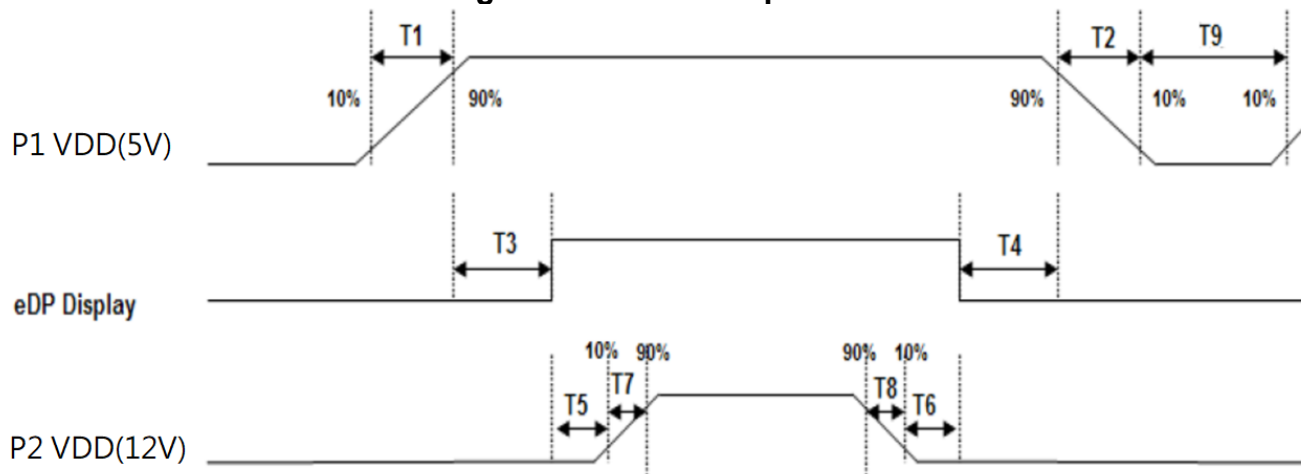

Table 8-2 Power Sequencing Requirements

Parameter	Unit	Min.	Max.
T1	ms	0.5	10
T2	ms	0	10
T3	ms	0	200
T4	ms	0	50
T5	ms	300	-
T6	ms	200	-
T7	ms	0.5	10
T8	ms	0	10
T9	ms	500	-

9. Optical Characteristics

Item	Symbol	Condition.	Min	Typ.	Max.	Unit	Remark	
Response time	Tr+ Tf	$\theta=0^\circ$ 、 $\Phi=0^\circ$	-	25	35	.ms	Note 3	
Contrast ratio	CR	At optimized viewing angle	600	800	-	-	Note 4,	
Color Chromaticity	White	Wx	$\theta=0^\circ$ 、 $\Phi=0$	0.263	0.313	0.363	Note 2,6,7	
		Wy		0.279	0.329	0.379		
Viewing angle	Hor.	Θ_R	$CR \geq 10$	85	89	-	Deg.	Note 1
		Θ_L		85	89	-		
	Ver.	Φ_T		85	89	-		
		Φ_B		85	89	-		
Brightness	-	-	360	450	-	cd/m ²	Center of display	
Uniformity	(U)	-	70	-	-	%	Note 5	

Ta=25±2°C

Note 1: Definition of viewing angle range

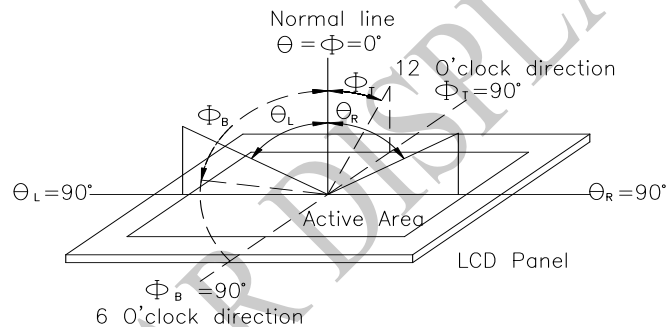

Fig 9.1. Definition of viewing angle

Note 2: Test equipment setup:

After stabilizing and leaving the panel alone at a driven temperature for 10 minutes, the measurement should be executed. Measurement should be executed in a stable, windless, and dark room. Optical specifications are measured by Topcon BM-7 or BM-5 luminance meter 1.0° field of view at a distance of 50cm and normal direction.

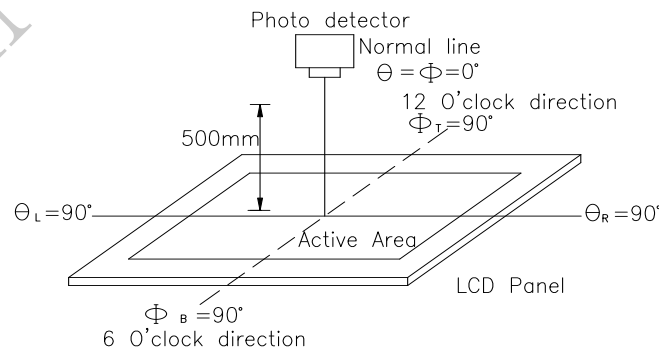
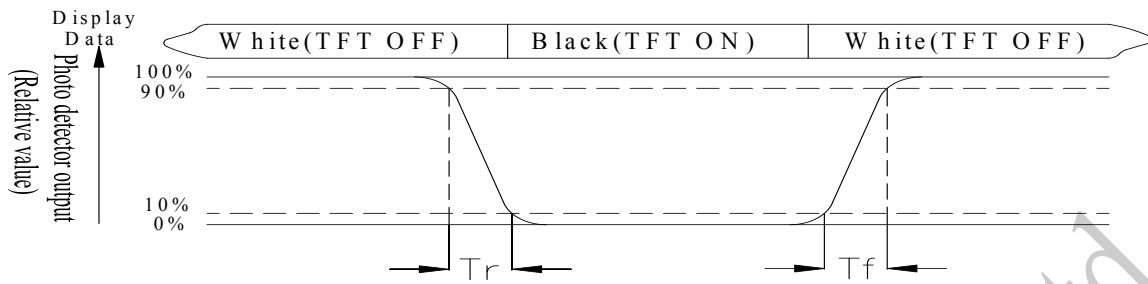

Fig 9.2. Optical measurement system setup

Note 3: Definition of Response time:

The response time is defined as the LCD optical switching time interval between "White" state

and “Black” state. Rise time, T_r , is the time between photo detector output intensity changed from 90% to 10%. And fall time, T_f , is the time between photo detector output intensity changed from 10% to 90%



Note 4: Definition of contrast ratio:

The contrast ratio is defined as the following expression.

$$\text{Contrast ratio (CR)} = \frac{\text{Luminance measured when LCD on the "White" state}}{\text{Luminance measured when LCD on the "Black" state}}$$

Note 5: Definition of Luminance Uniformity

Active area is divided into 9 measuring areas (reference the picture in below). Every measuring point is placed at the center of each measuring area.

$$\text{Luminance Uniformity (U)} = L_{\min}/L_{\max} \times 100\%$$

L = Active area length

W = Active area width

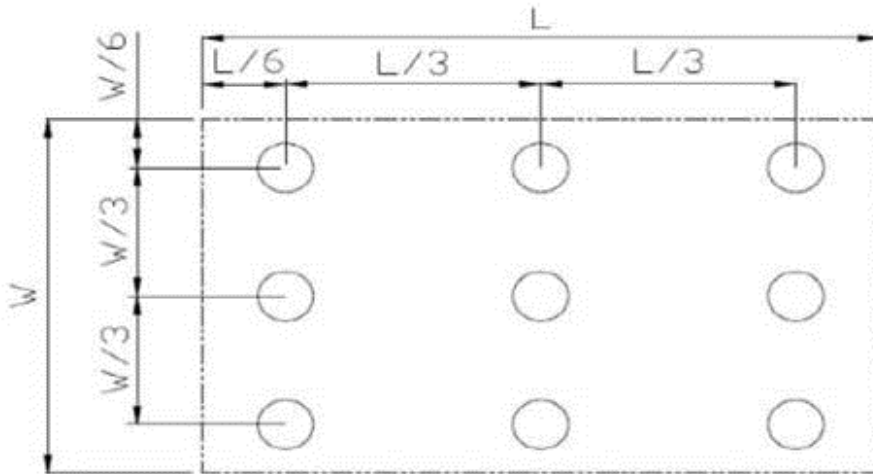

Fig 9.3. Definition of uniformity

Note 6: Definition of color chromaticity (CIE 1931)

Color coordinates measured at the center point of LCD

Note 7: Measured at the center area of the panel when all the input terminals of LCD panel are electrically opened.

Interface

10.1. CON2 : LCM PIN Definition

Pin No.	Signal Name	Description	Remarks
1	NC	Not connection	
2	GND	Ground	
3	DP1-	Complement Signal Link Lane 1	
4	DP1+	True Signal Line 1	
5	GND	Ground	
6	DP0-	Complement Signal Link Lane 0	
7	DP0+	True Signal Line 0	
8	GND	Ground	
9	AUX+	True Signal Auxiliary Ch.	
10	AUX-	Complement Signal Auxiliary Ch.	
11	GND	Ground	
12-14	NC	Not connection (If Pin 12 and Pin 13 have voltage input, it will not affect the use)	
15-16	GND	Ground	
17	HPD	HPD Signal Pin	
18-21	GND	Ground	
22	NC(BL_EN)	Not connection	
23	NC(BL_PWM)	Not connection	
24-30	NC	Not connection(If Pin 26~Pin 29 have voltage input, it will not affect the use)	

Note: All input signals shall be low or Hi-Z state when P1 VDD is off

10.2. 10.CON3 : Back light PIN Definition

Pin No.	Signal Name	Description	Remarks
1	GND	Ground	
2	BL_EN	Back light Enable On/Off	
3	BL_UP	Back light Increment Backlight Brightness	
4	BL_DN	Back light Decrement Backlight Brightness	

Note:

1. An on-screen display (OSD) ,the internal control of brightness will need to switch CON3 to Pin3~Pin4. (BL_EN, BL_UP, BL_DN default is Hi, If not used, open this pin)
2. 100% brightness is preset and the adjustable range will be 0~100%(16 steps)
3. After adjusting the brightness, the brightness will be automatically memorized after 10 seconds.

WINSTAR DISPLAY Co., Ltd.

4. OSD external hardware (Switch) and software (GPIO) control reference is as follows

OSD configuration(Hartware SWITCH)

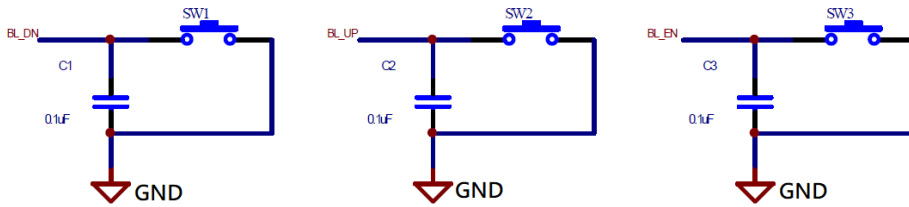

OSD configuration(Software GPIO)

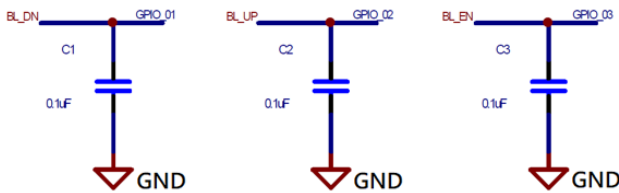

When SWITCH or GPIO sends a one-time Low level signal, it will trigger the OSD action, and wait for the next one-time Low level signal to perform the actions of LB_DN, BL_UP, and BL_EN

10.3. P1 : Supply Voltage For LCM

Pin No.	Signal Name	Description	Remarks
1	5V	Power supply +5V	
2	GND	Ground	
3	NC	Not connection	

10.4. P2 : Supply Voltage For Back Light

Pin No.	Signal Name	Description	Remarks
1	12V	Power supply +12V	
2	GND	Ground	
3	NC	Not connection	

11. Block Diagram

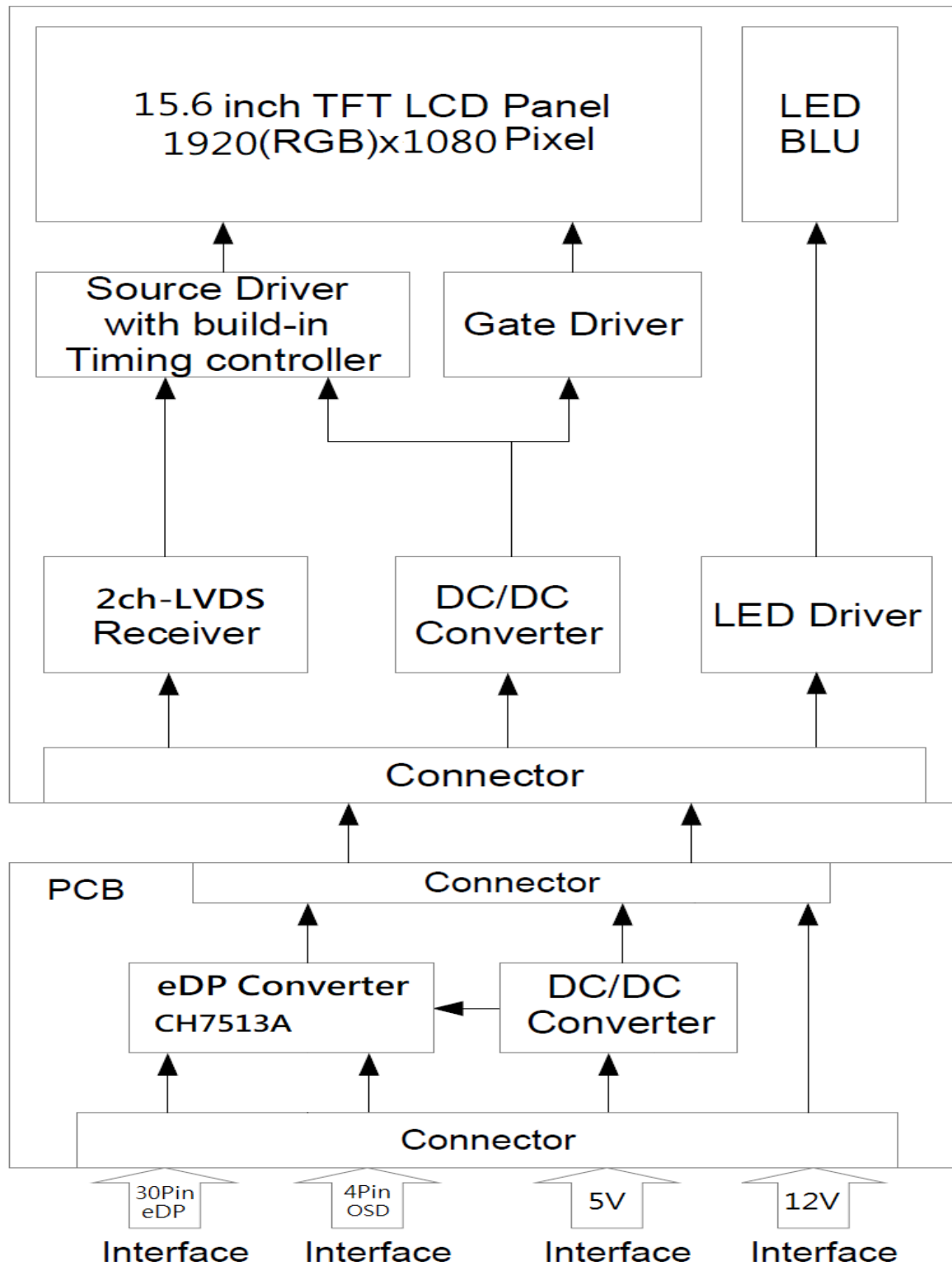

12. Reliability

Content of Reliability Test (Super Wide temperature, -30°C~85°C)

Environmental Test			
Test Item	Content of Test	Test Condition	Note
High Temperature storage	Endurance test applying the high storage temperature for a long time.	90°C 200hrs	2
Low Temperature storage	Endurance test applying the low storage temperature for a long time.	-40°C 200hrs	1,2
High Temperature Operation	Endurance test applying the electric stress (Voltage & Current) and the thermal stress to the element for a long time.	85°C 200hrs	2
Low Temperature Operation	Endurance test applying the electric stress under low temperature for a long time.	-30°C 200hrs	1,2
High Temperature/ Humidity Operation	The module should be allowed to stand at 60°C,90%RH max	60°C,90%RH 96hrs	1,2
Thermal shock resistance	The sample should be allowed stand the following 10 cycles of storage <div style="text-align: center;"> <p style="margin: 0;">-30°C 25°C 85°C</p> <p style="margin: 0;">←-----→</p> <p style="margin: 0;">30min 5min 30min</p> <p style="margin: 0;">1 cycle</p> </div>	-30°C/85°C 10 cycles	2
Vibration test	Endurance test applying the vibration during transportation and using.	Total fixed amplitude : 1.5mm Vibration Frequency : 10~55Hz One cycle 60 seconds to 3 directions of X,Y,Z for Each 15 minutes	3
Static electricity test	Endurance test applying the electric stress to the terminal.	VS=±6KV(contact), ±8KV(air), RS=330Ω CS=150pF 10 times	4

Note1: No dew condensation to be observed.

Note2: The function test shall be conducted after 4 hours storage at the normal Temperature and humidity after remove from the test chamber.

Note3: The packing have to including into the vibration testing.

Note4: Endurance test applying the electric stress to the finished product housing

13. Contour Drawing

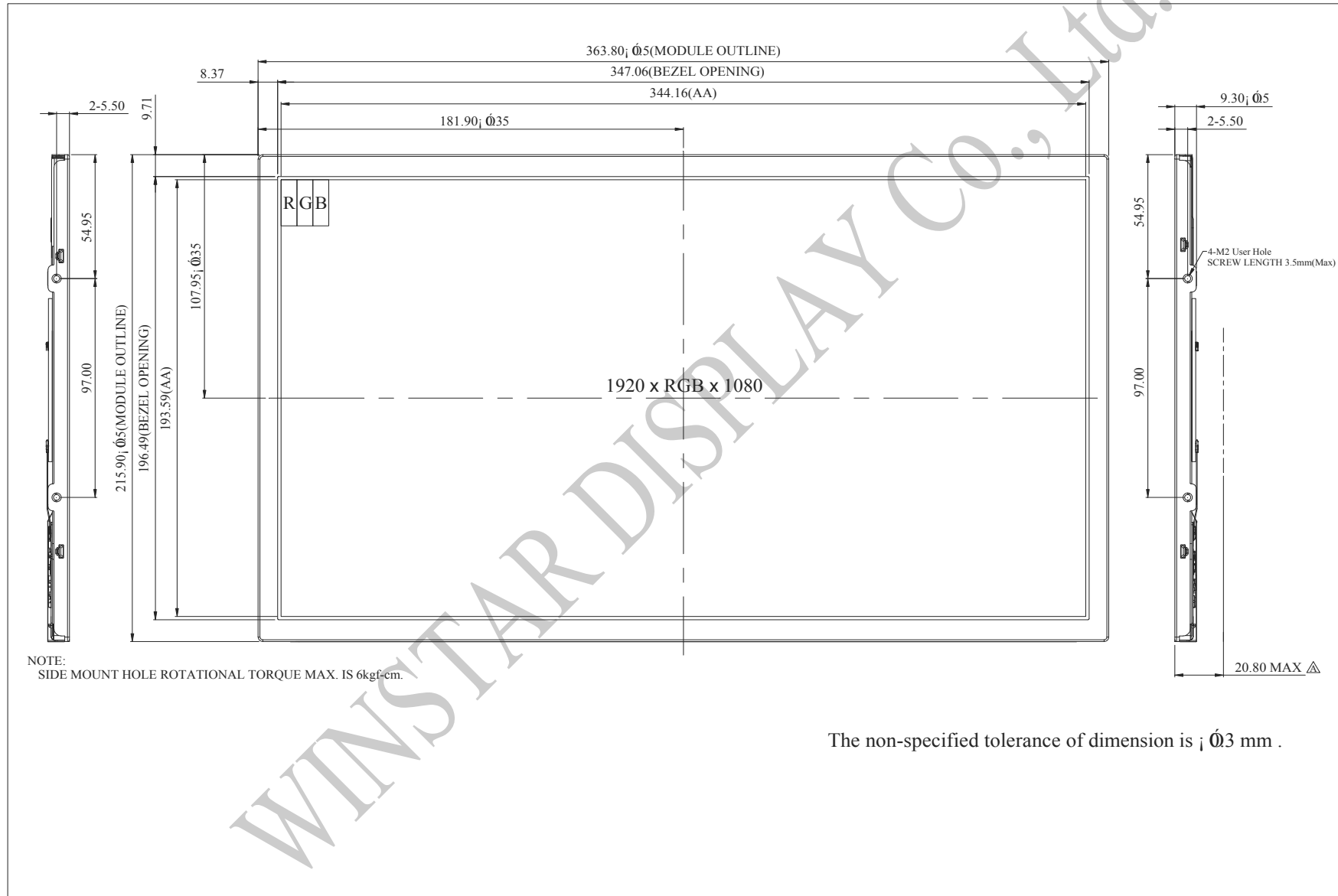

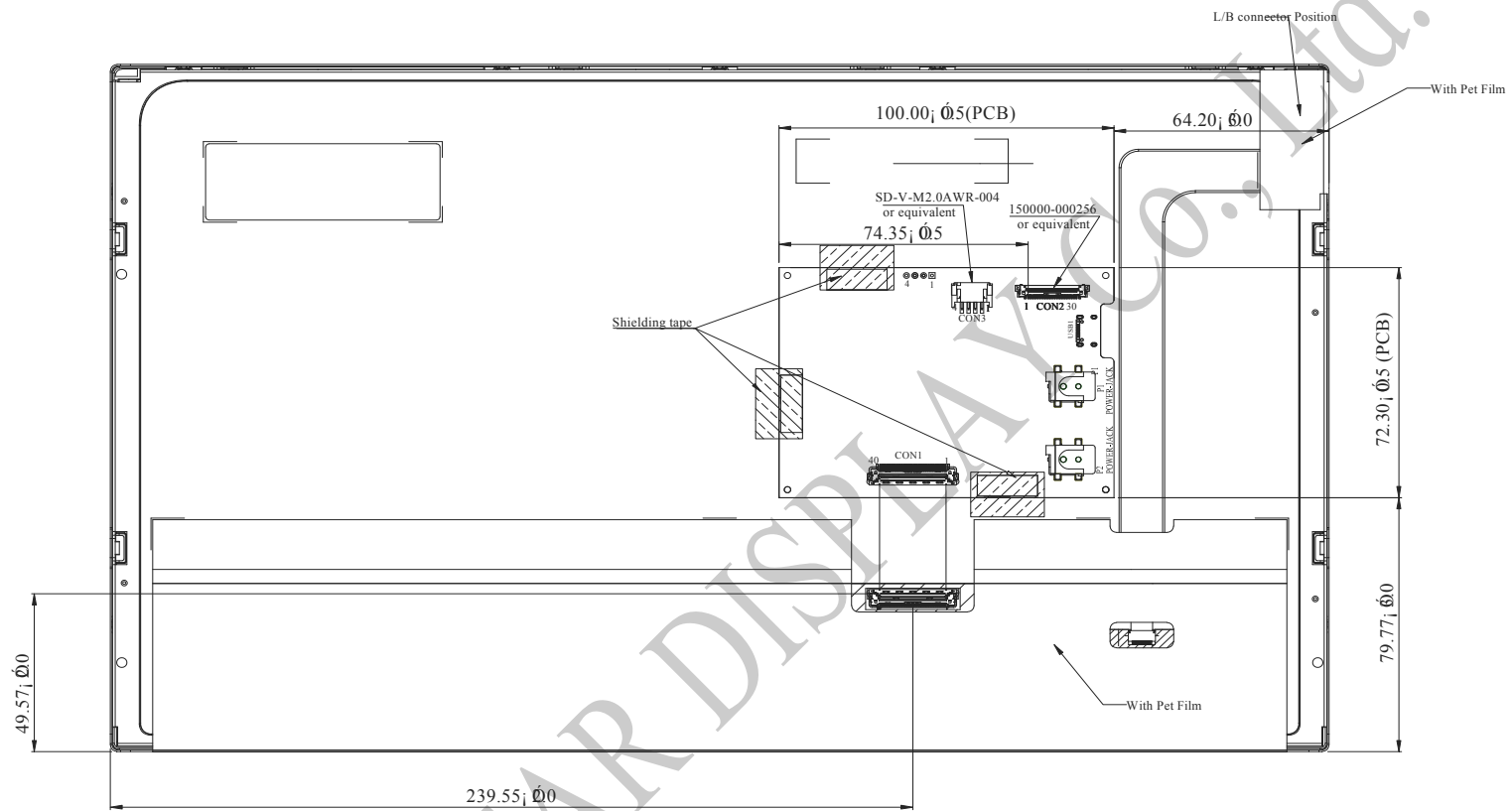

CON3

PIN NO.	SYMBOL
1	GND
2	BL_EN
3	BL_UP
4	BL_DN

P1

PIN NO.	SYMBOL
1	5V
2	GND
3	NC

2 — ● — 1
(GND) (5V)

P2

PIN NO.	SYMBOL
1	12V
2	GND
3	NC

2 — ● — 1
(GND) (12V)

CON2

PIN NO.	SYMBOL	PIN NO.	SYMBOL	PIN NO.	SYMBOL	PIN NO.	SYMBOL	PIN NO.	SYMBOL	PIN NO.	SYMBOL
1	NC	6	DP0-	11	GND	16	GND	21	GND	26	NC
2	GND	7	DP0+	12	NC	17	HPD	22	NC(BL_EN)	27	NC
3	DP1-	8	GND	13	NC	18	GND	23	NC(BL_PWM)	28	NC
4	DP1+	9	AUX+	14	NC	19	GND	24	NC	29	NC
5	GND	10	AUX-	15	GND	20	GND	25	NC	30	NC

The non-specified tolerance of dimension is ± 0.3 mm .

14. Inspection Specification

14.1. Description

These inspection standards shall be applied to LCD Module supplied by Winstar. This model is only used for Industry product. If there are any other product applications such as handwriting recognition, Medical use, Automobile, Aerospace use and so on, the specification should be negotiated separately.

14.2. The environmental condition of inspection

The environmental condition and visual inspection shall be conducted as below.

- (1) Ambient temperature : 15~25°C
- (2) Humidity : 25~75 %RH
- (3) External appearance inspection shall be conducted by using a single 20W fluorescent lamp or equivalent illumination.
- (4) Panel visual inspection on the operation condition for cosmetic shall be conducted at the distance 35cm or more between the LCD module and eyes of inspector.
Ambient Illumination : 300 ~ 500 Lux for external appearance inspection
Ambient Illumination : 100 ~ 200 Lux for light on inspection
- (5) The viewing angle :
 - a) 15 degree to the front surface of display panel in vertical direction.
 - b) 45 degree to the front surface of display panel in horizontal direction.
- (6) ND filter shall be conducted at the dist

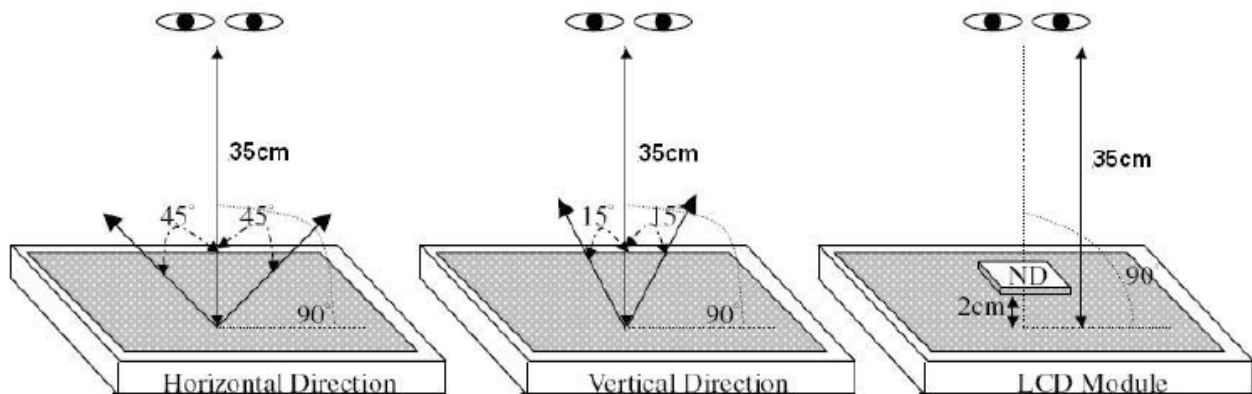

14.3. Classification of defects

Defects are classified two types, major defect and minor defect according to the defect. And, the definition of defects is classified as below.

(1) Major defect

Any defect may result in functional failure, or reduce the usability of product for its purpose. For example, electrical failure, deformation and etc..

(2) Minor defect

A defect that is not to reduce the usability of product for its intended purpose and un-uniformity, dot defect and etc..

The criteria on major or minor judgment will be according with the classification of defects, and any defects out of active area, are not considered as a defect or counted.

14.4. Inspection Criteria

(1) Definition of dot defect induced from the panel inside

a. Bright dot :Dots appear bright and unchanged in size in which module is displaying under black pattern.

b. Dark dot :Dots appear dark and unchanged in size in which module is displaying under pure red,green, blue, white picture.

c. 2 Full dot adjacent = 1pair.

d. Picture :

(a) Full dot

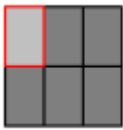

(b) 2 Full dot adjacent



(c) Spot defect

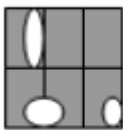

(2) Display Inspection standards when power on.

Items		Acceptable count
Full Bright dot	Random	$N \leq 2$
	2 dots adjacent	$N \leq 1$
	3 dots adjacent or more	$N \leq 0$
Full Dark dot	Random	$N \leq 3$
	2 dots adjacent	$N \leq 1$
	3 dots adjacent or more	$N \leq 0$
Total full bright and full dark dot		$N \leq 5$
Foreign Black/White/Bright Spot		$D \leq 0.15\text{mm}$, Ignore $0.15 < D \leq 0.5\text{ mm}$, $N \leq 4$
Foreign Black/White/Bright Line		$W \leq 0.05\text{mm}$, Ignore $0.05 < W \leq 0.1\text{ mm}$, $0.3 < L \leq 2.0\text{ mm}$, $N \leq 4$
Polarizer	Scratches	$W \leq 0.05\text{mm}$, Ignore $0.05 < W \leq 0.1\text{ mm}$, $0.3 < L \leq 2.0\text{ mm}$, $N \leq 4$
	Dent /Bubble	Avg. $0.15 < D \leq 0.5\text{ mm}$, $N \leq 4$
Distance	Minimum Distance Between Full Bright dots	$L \geq 10\text{mm}$
	Minimum Distance Between Full Dark dots	$L \geq 10\text{mm}$
Display failure (V-line/H-line/Cross line etc.)		Not allowable
Mura	Not visible through 6% ND filter in 50% gray or judge by limit sample if necessary	

14.5. External Appearance Inspection Criteria (Power off)

Item	Contents	
Screw	Parts mounting, incomplete assembly, deformation, oxidized, crooked or rusty is not permitted.	
CCFL cable (For CCFL Model)	Cable not continuous 、 Break-off 、 Connector Burn-off /Break-off	
Metal frame (Bezel)	Scratch	*Noticeable scratch and exfoliation coating are not permitted. *The oxidized metal is not permitted.
	Incomplete assembly is not permitted.	
Backlight	Scratch	The scratch which may causes a problem in practical use is not permitted.
	Break-off	Breaking off is not permitted.
	Crack	The crack is not permitted.
Polarizer	Scratches	$W \leq 0.05\text{mm}$, Ignore $0.05 < W \leq 0.1 \text{ mm}$, $0.3 < L \leq 10.0 \text{ mm}$, $N \leq 4$
	Dent/Bubble	Avg. $0.15 < D \leq 0.5 \text{ mm}$, $N \leq 4$
	Stain	The stain on polarizer, which can't be wiped off, is not permitted.
Tape/Label	Incorrect position, missed label is not permitted.	
Connector	Oxidized/rusty connector is not permitted.	
Outline size	Spec. out is not permitted.	

*Note: If any specific defect is not included in the above defect table, this defect should be judged by INX/ODM/Brand customer discussion.

Note.1

$$D=(a+b)/2$$



Note.2

W: width, L : length

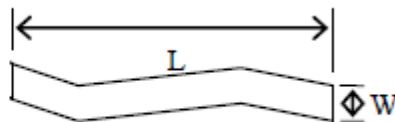

14.6. Classification of defects

Inspection Item	Criteria and Description	Defect type
Vertical line	Signal input, vertical line off or irregular V-line appears	major
Horizontal line	Signal input, horizontal line off or irregular H-line appears	major
Cross line	Pattern signal input, a correct display is not obtained	major
No display	Signal input, display is dead	major
Irregular display	Pattern signal input, a correct display is not obtained	major
Dots defect	Exceed specified standards	minor
Scratch and Dent on polarizer	Exceed specified standards	minor
Foreign material	Exceed specified standards	minor
Mura	Non-uniformity is appeared in display	minor
Polarizer bubble	Exceed specified standards	minor



1、Panel Specification :

- 1. Panel Type : Pass NG , _____
- 2. View Direction : Pass NG , _____
- 3. Numbers of Dots : Pass NG , _____
- 4. View Area : Pass NG , _____
- 5. Active Area : Pass NG , _____
- 6. Operating Temperature : Pass NG , _____
- 7. Storage Temperature : Pass NG , _____
- 8. Others : _____

2、Mechanical

- 1. PCB Size : Pass NG , _____
- 2. Frame Size : Pass NG , _____
- 3. Material of Frame : Pass NG , _____
- 4. Connector Position : Pass NG , _____
- 5. Fix Hole Position : Pass NG , _____
- 6. Backlight Position : Pass NG , _____
- 7. Thickness of PCB : Pass NG , _____
- 8. Height of Frame to PCB : Pass NG , _____
- 9. Height of Module : Pass NG , _____
- 10. Others : Pass NG , _____

3、Relative Hole Size :

- 1. Pitch of Connector : Pass NG , _____
- 2. Hole size of Connector : Pass NG , _____
- 3. Mounting Hole size : Pass NG , _____
- 4. Mounting Hole Type : Pass NG , _____
- 5. Others : Pass NG , _____

4、Backlight Specification :

- 1. B/L Type : Pass NG , _____
- 2. B/L Color : Pass NG , _____
- 3. B/L Driving Voltage (Reference for LED Temperature) : Pass NG , _____
- 4. B/L Driving Current : Pass NG , _____
- 5. Brightness of B/L : Pass NG , _____
- 6. B/L Solder Method : Pass NG , _____
- 7. Others : Pass NG , _____

>> **Go to page 2** <<



Winstar Module Number : _____

Page: 2

5、Electronic Characteristics of Module :

- | | | |
|------------------------------|-------------------------------|-------------------------------------|
| 1. Input Voltage : | <input type="checkbox"/> Pass | <input type="checkbox"/> NG , _____ |
| 2. Supply Current : | <input type="checkbox"/> Pass | <input type="checkbox"/> NG , _____ |
| 3. Driving Voltage for LCD : | <input type="checkbox"/> Pass | <input type="checkbox"/> NG , _____ |
| 4. Contrast for LCD : | <input type="checkbox"/> Pass | <input type="checkbox"/> NG , _____ |
| 5. B/L Driving Method : | <input type="checkbox"/> Pass | <input type="checkbox"/> NG , _____ |
| 6. Negative Voltage Output : | <input type="checkbox"/> Pass | <input type="checkbox"/> NG , _____ |
| 7. Interface Function : | <input type="checkbox"/> Pass | <input type="checkbox"/> NG , _____ |
| 8. LCD Uniformity : | <input type="checkbox"/> Pass | <input type="checkbox"/> NG , _____ |
| 9. ESD test : | <input type="checkbox"/> Pass | <input type="checkbox"/> NG , _____ |
| 10. Others : | <input type="checkbox"/> Pass | <input type="checkbox"/> NG , _____ |

6、Summary :

Sales signature : _____

Customer Signature : _____

Date : / / _____

WINSTAR DISPLAY CO., Ltd.