



晶采光電科技股份有限公司
AMPIRE CO., LTD.

SPECIFICATIONS FOR LCD MODULE

| | |
|--------------------------|-----------------------------|
| CUSTOMER | |
| CUSTOMER PART NO. | |
| AMPIRE PART NO. | AM-800480R3TMQW-TB1H |
| APPROVED BY | |
| DATE | |

- Approved For Specifications
 Approved For Specifications & Sample

AMPIRE CO., LTD.
4F., No.116, Sec. 1, Xintai 5th Rd., Xizhi Dist., New Taipei City 221,
Taiwan (R.O.C.) 22181 新北市 汐止區新台五路一段 116 號 4F
TEL:886-2-26967269 , FAX:886-2-26967196 or 26967270

| APPROVED BY | CHECKED BY | ORGANIZED BY |
|-------------|------------|--------------|
| | | |

RECORD OF REVISION

| Revision Date | Page | Contents | Editor |
|----------------------|-------------|---|---------------|
| 2011/02/14 | -- | New Release | Emil |
| 2011/09/06 | 4 | Adjust the Power Supply Current to 380mA | Titan |
| 2011/09/06 | 5 | Adjust the LED Backlight Current to 180mA | Titan |
| 2011/11/10 | 8 | Correct the PWM frequency to 100Hz~200KHz | Emil |
| 2012/8/7 | 21 | Correct PIN6=VLED. | Kokai |
| | 22 | Modify Outline dimension drawing | |

1. INTRODUCTION

Ampire Display Module is a color active matrix TFT-LCD that uses amorphous silicon TFT as a switching device. This model is composed of a TFT-LCD panel, timing controller and LED driver. This TFT-LCD has a high resolution (800(R.G.B) X 480) and can display up to 262,144 colors.

1-1. Features

- 7" WVGA (16:9 diagonal) configuration
- Input interface voltage : 3.3V
- Data enable mode
- LED driver : 5V input
- LED Back-light is with FPC connection.

1-2. Applications

- Portable TV
- Car user DVD
- Industrial application
- HMI (Human machine interface)

2. PHYSICAL SPECIFICATIONS

| Item | Specifications | unit |
|-------------------------|----------------------------|-------------------|
| Display resolution(dot) | 800RGB (W) x 480(H) | dots |
| Active area | 152.4 (W) x 91.44 (H) | mm |
| Pixel pitch | 0.1905 (W) x 0.1905 (H) | mm |
| Color configuration | R.G.B Vertical stripe | |
| Overall dimension | 165.0(W)x104.44(H)x8.32(T) | mm |
| Brightness | 240 nit | cd/m ² |
| Contrast ratio | 400 : 1 | |
| Backlight unit | LED | |
| Display color | 262,144 | colors |

3. ABSOLUTE MAX. RATINGS

| ITEM | SYMBOL | MIN | MAX | UNIT |
|------------------------------|---------------------------------------|------|---------|------|
| Power Supply Voltage for LCD | Vcc | -0.5 | 6.0 | V |
| Signal input voltage | DCLK DE R0~R5 G0~G5 B0~b5 | -0.5 | VCC+0.3 | V |
| Operation Temperature | Top | -20 | 70 | °C |
| Storage Temperature | Tstg | -30 | 80 | °C |

The following values are maximum operation conditions , If exceeded , it may cause faulty operation or damage

4. ELECTRICAL CHARACTERISTICS

4-1 TFT LCD Module voltage

| ITEM | SYMBOL | MIN | TYP | MAX | UNIT | CONDITION |
|------------------------------|-------------------------|-----------------|--------|---------------|--------|---------------|
| Power Supply Voltage For LCD | Vcc | 3.0 | 3.3 | 3.6 | V | |
| Power Supply Current For LCD | Icc | - | 170 | 220 | mA | Black pattern |
| Logic Input Voltage | Input Voltage | V _{IN} | 0 | - | Vcc | V |
| | Threshold Voltage(High) | V _{TH} | 0.7Vcc | - | Vcc | V |
| | Threshold Voltage(Low) | V _{TL} | 0 | - | 0.3Vcc | V |
| Power Supply Voltage For LED | VLED | 4.5 | 5.0 | 5.5 | V | |
| Power Supply Current For LED | ILED | - | 380 | - | mA | VLED=5V |
| ADJ signal frequency | f _{PWM} | 100 | -- | 1K | Hz | |
| ADJ signal logic level High | V _{IH} | 2V | | (VLED) 5.0 | V | |
| ADJ signal logic level Low | V _{IL} | 0 | - | 0.5 | V | |

4-2 LED Driving Conditions

| ITEM | SYMBOL | MIN | TYP | MAX | UNIT | CONDITION |
|-----------------------|----------|-----|-----|------|------|--------------------------|
| LED Backlight Voltage | V_{BL} | 8.4 | -- | 10.8 | V | For reference |
| LED Backlight Current | I_{BL} | - | 180 | - | mA | $T_a=25^{\circ}\text{C}$ |
| LED Life Time | | | 30K | | Hr | Note* |

Note*: Brightness to be decreased to 50% of the initial value.

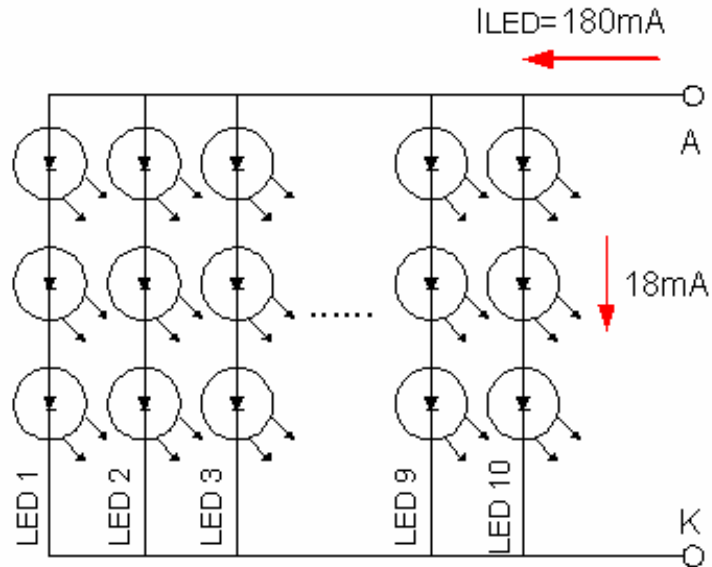

The constant current source is needed for white LED back-light driving.

When LCM is operated over 60°C ambient temperature, the I_{BL} of the LED back-light should be adjusted to 135mA max

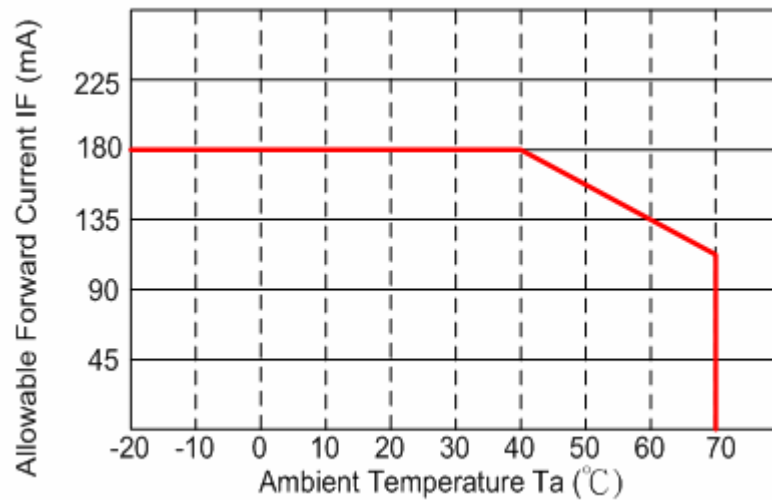

4-3 TOUCH PANEL ELECTRICAL SPECIFICATION

| Parameter | Condition | Standard Value |
|-----------------------|-----------|------------------------|
| Terminal Resistance | X Axis | 180 ~ 670 Ω |
| | Y Axis | 140 ~ 560 Ω |
| Insulating Resistance | DC 25 V | More than 20M Ω |
| Linearity | -- | $\leq 1.5 \%$ |
| Notes life by Pen | Note a | 100,000 times(min) |
| Input life by finger | Note b | 1,000,000 times (min) |

Note A .

Notes area for pen notes life test is 10 x 9 mm.

Size of word is 7.5 x 6.75

Shape of pen end : R0.8mm

Load : 250 g

Note B

By Silicon rubber tapping at same point

Shape of rubber end : R8mm

Load : 250gf

Frequency : 5 Hz

Interface

| No. | Symbol | Function |
|-----|--------|-------------------------------------|
| 1 | Y2 | Touch Panel Top Signal in Y Axis |
| 2 | X2 | Touch Panel Right Signal in X Axis |
| 3 | Y1 | Touch Panel Bottom Signal in Y Axis |
| 4 | X1 | Touch Panel Left Signal in X Axis |

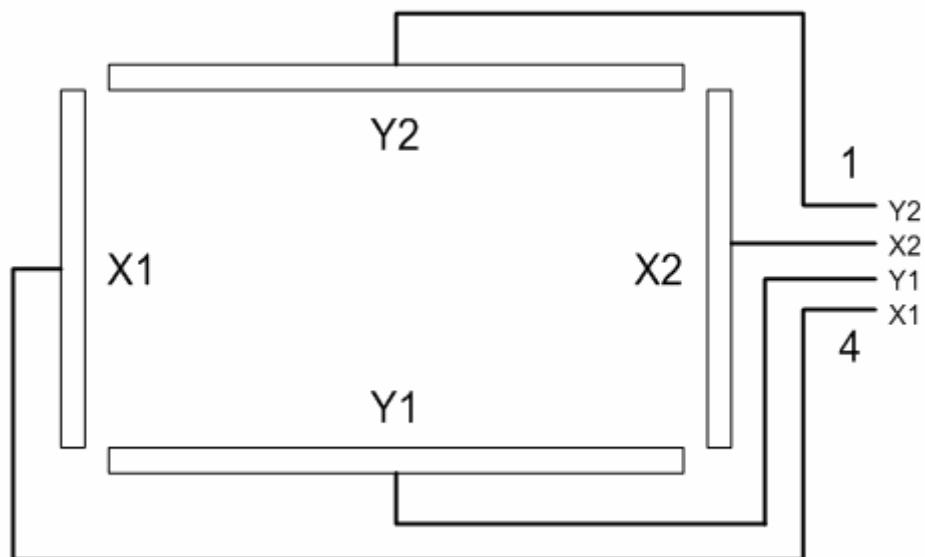

5. INTERFACE

| Pin No | Symbol | Function |
|--------|--------|---------------------------------------|
| 1 | LGND | LED Driver Ground |
| 2 | LGND | LED Driver Ground |
| 3 | ADJ | Adjust for LED Brightness |
| 4 | VLED | Power supply for LED (5V) |
| 5 | VLED | Power supply for LED (5V) |
| 6 | VLED | Power supply for LED (5V) |
| 7 | VCC | Power supply for LCD (3.3V) |
| 8 | VCC | Power supply for LCD (3.3V) |
| 9 | DE | Data Enable Timing Signal |
| 10 | GND | Ground |
| 11 | GND | Ground |
| 12 | GND | Ground |
| 13 | B5 | Blue data (MSB) |
| 14 | B4 | Blue data |
| 15 | B3 | Blue data |
| 16 | GND | Ground |
| 17 | B2 | Blue data |
| 18 | B1 | Blue data |
| 19 | B0 | Blue data (LSB) |
| 20 | GND | Ground |
| 21 | G5 | Green data (MSB) |
| 22 | G4 | Green data |
| 23 | G3 | Green data |
| 24 | GND | Ground |
| 25 | G2 | Green data |
| 26 | G1 | Green data |
| 27 | G0 | Green data (LSB) |
| 28 | GND | Ground |
| 29 | R5 | Red data (MSB) |
| 30 | R4 | Red data |
| 31 | R3 | Red data |
| 32 | GND | Ground |
| 33 | R2 | Red data |
| 34 | R1 | Red data |
| 35 | R0 | Red data (LSB) |
| 36 | GND | Ground |
| 37 | GND | Ground |
| 38 | DCLK | Data Clock |
| 39 | NC | No Connection (need to be floating) |
| 40 | NC | No Connection (need to be floating) |

Note1: ADJ is PWM signal input. It is for brightness control.

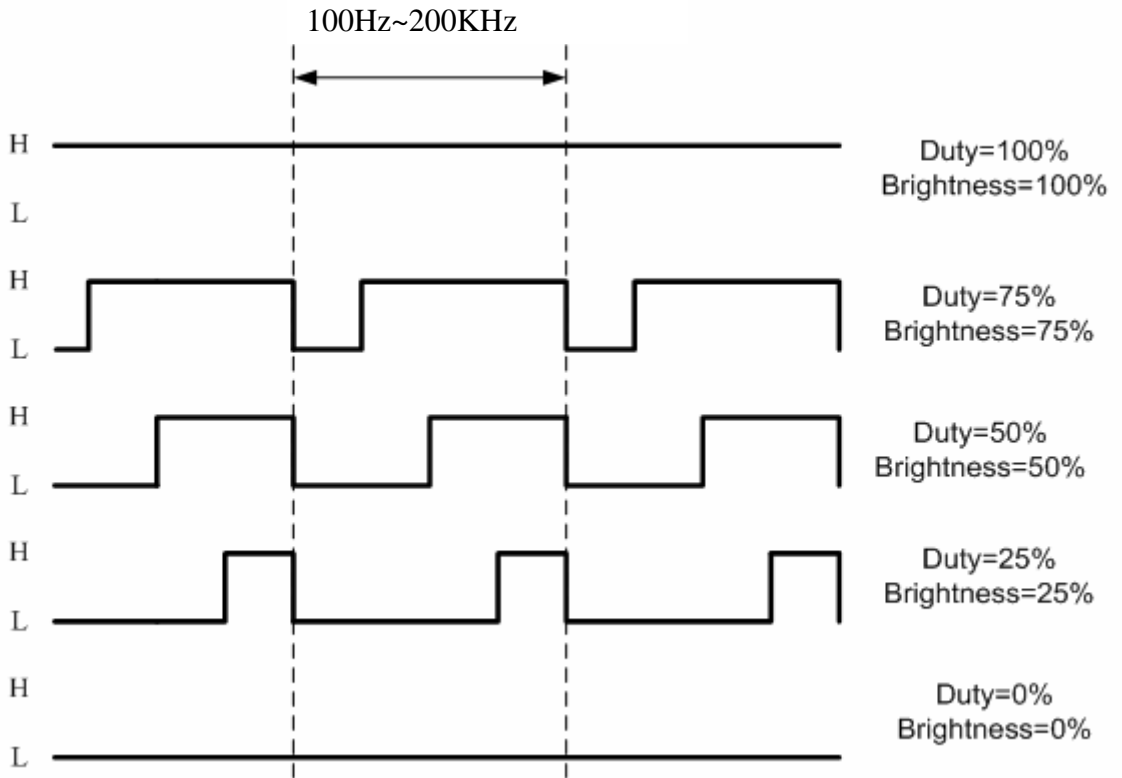

6. OPTICAL CHARACTERISTICS

| Item | Symbol | Condition | Min. | Typ. | Max. | Unit | Note | |
|----------------------|------------|---------------------------|--------------|-------|-------|-------------------|-----------|-----------|
| Viewing Angle | Front | θf | $CR \geq 10$ | 55 | 60 | -- | deg. | (1)(2)(3) |
| | Back | θb | | 55 | 60 | -- | | |
| | Left | θl | | 65 | 70 | -- | | |
| | Right | θr | | 65 | 70 | -- | | |
| Contrast ratio | CR | $\Theta = \Phi = 0^\circ$ | 250 | 400 | -- | -- | (1)(3) | |
| Response Time | T_r | $\Theta = \Phi = 0^\circ$ | -- | 5 | 10 | ms | (1)(4) | |
| | T_f | | -- | 11 | 16 | ms | (1)(4) | |
| Color chromaticity | White | | W_x | 0.239 | 0.299 | 0.359 | -- | (1) |
| | | | W_y | 0.268 | 0.328 | 0.388 | | |
| Luminance | L | $\Theta = \Phi = 0^\circ$ | 200 | 240 | -- | cd/m ² | (1)(5) | |
| Luminance Uniformity | ΔL | $\Theta = \Phi = 0^\circ$ | 70 | -- | -- | % | (1)(5)(6) | |

Note 1: $T_a = 25^\circ\text{C}$. To be measured on the center area of panel after 10 minutes operation.

Note 2: Definition of Viewing Angle

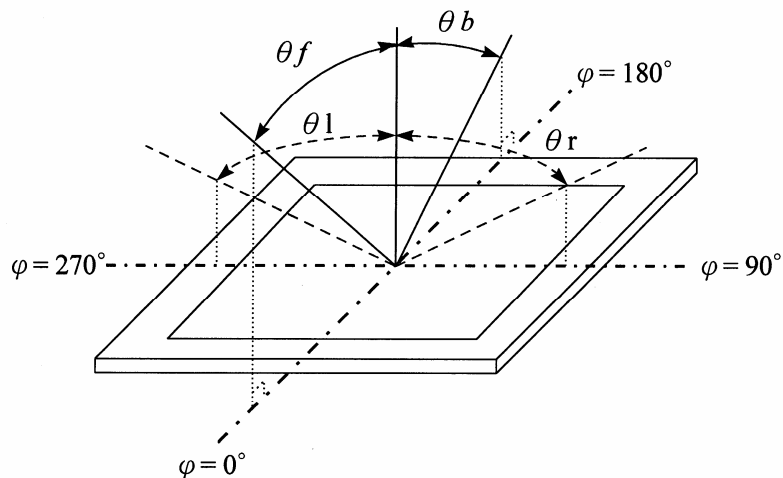

Note 3: Definition of contrast ratio:

Contrast ratio is calculated with the following formula.

$$\text{Contrast ratio(CR)} = \frac{\text{Photo detector output when LCD is at "White" state}}{\text{Photo detector Output when LCD is at "Black" state}}$$

Note 4: Definition of response time:

The output signals of photo detector are measured when the input signals are changed from "black" to "white"(falling time) and from "white" to "black" (rising time) respectively. The response time is defined as the time interval between the 10% and 90% of amplitudes. Refer to figure as below.

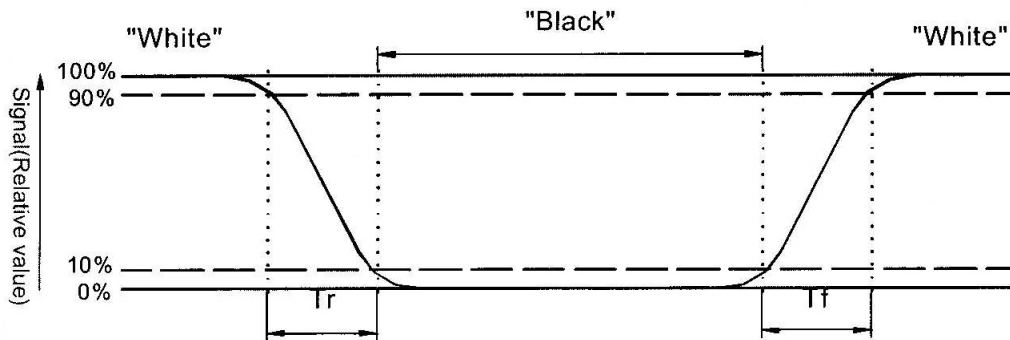

Note 5: Luminance is measured at point 5 of the display.

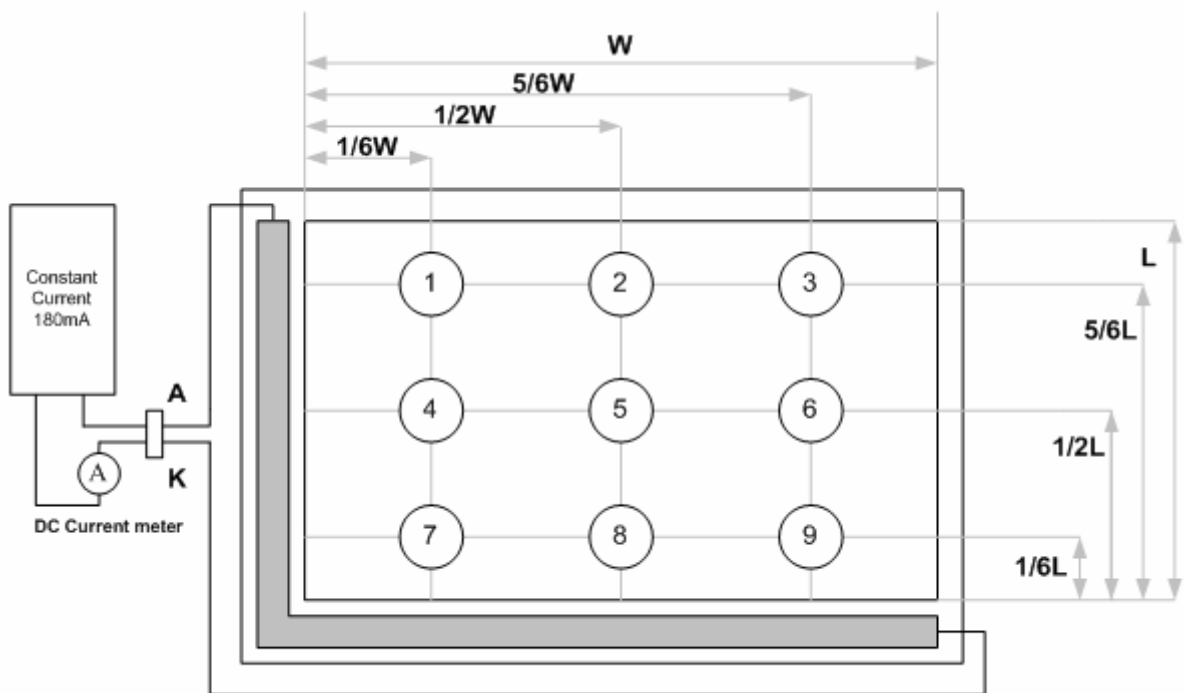

Note 6: Definition of Luminance Uniformity

$$\Delta L = [L(\text{min.}) \text{ of } 9 \text{ points} / L(\text{max.}) \text{ of } 9 \text{ points}] \times 100\%$$

7. INPUT SIGNAL (DE ONLY MODE)

| Parameter | Symbol | | | | Unit |
|-------------------|------------------------------------|------|-------|------|------------------------------------|
| | | Min. | Typ. | Max. | |
| Data setup time | Tdsu | 6 | - | - | ns |
| Data hold time | Tdhd | 6 | - | - | T _{CPH} |
| DE setup time | Tesu | 6 | - | - | T _{CPH} |
| CLK frequency | F _{CPH} | | 33.26 | | MHz |
| CLK period | T _{CPH} | | 30.06 | | ns |
| CLK pulse duty | T _{CWH} | 40 | 50 | 60 | % |
| DE period | T _{DEH} +T _{DEL} | 1000 | 1056 | 1200 | T _{CPH} |
| DE pulse width | T _{DEH} | - | 800 | - | T _{CPH} |
| DE frame blanking | T _{DEB} | 10 | 45 | 110 | T _{DEH} +T _{DEL} |
| DE frame width | T _{DE} | - | 480 | - | T _{DEH} +T _{DEL} |

Note : We suggest using the typical value, so it can have better performance.

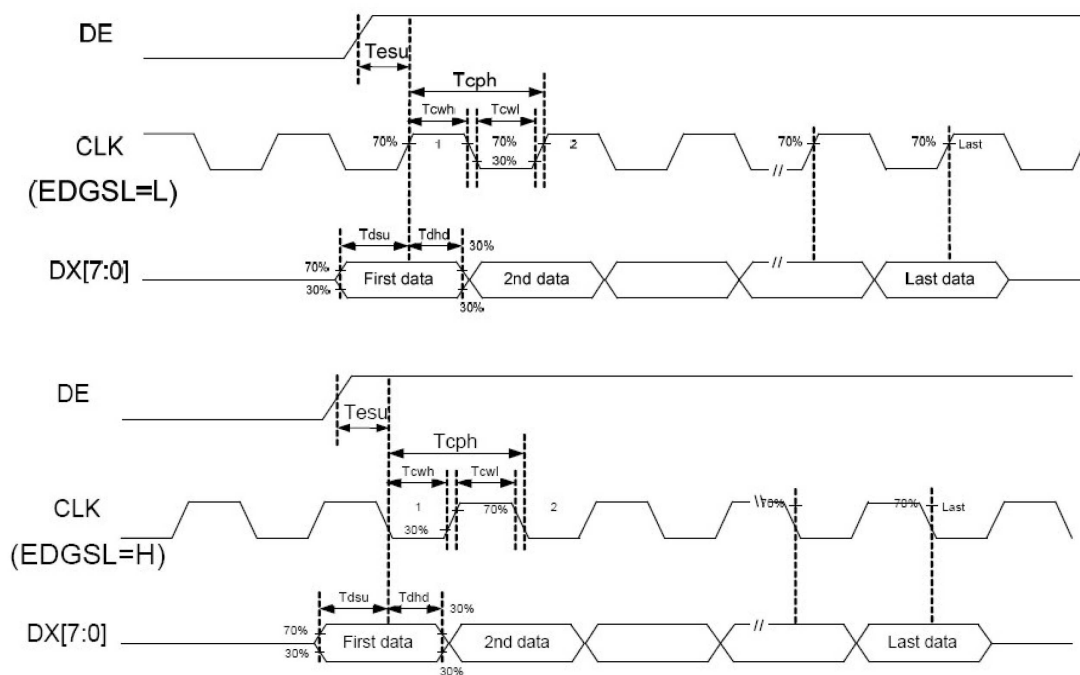

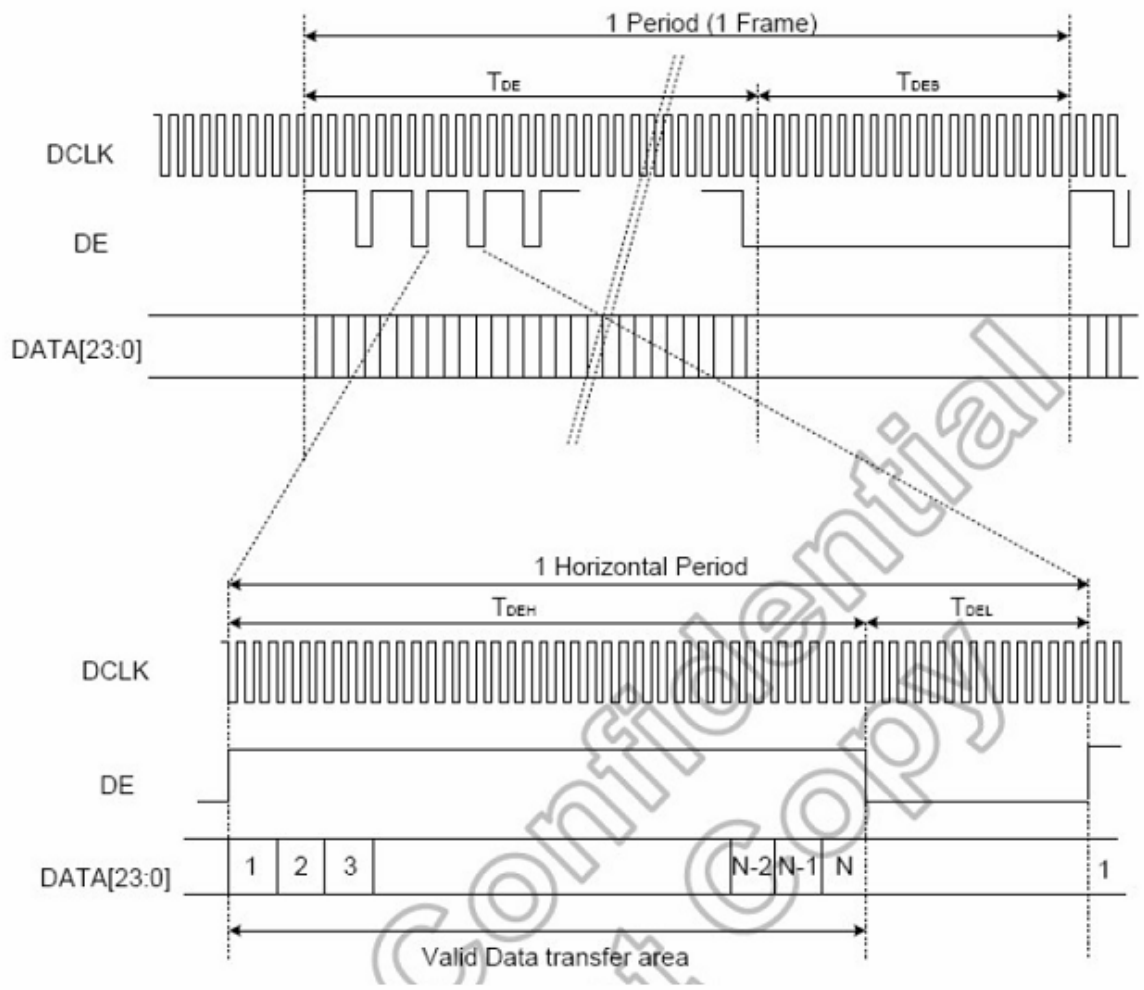

8. BLOCK DIAGRAM

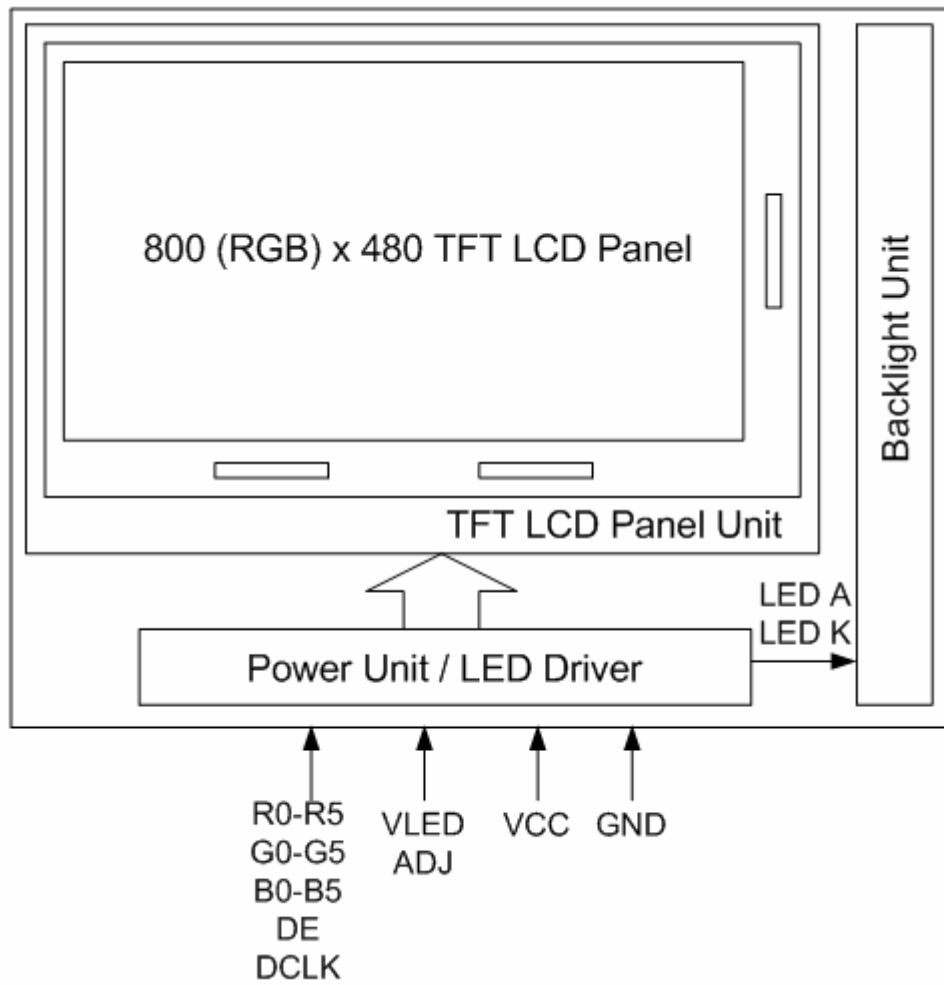

9. QUALITY AND RELIABILITY

9.1 TEST CONDITIONS

Tests should be conducted under the following conditions :

Ambient temperature : $25 \pm 5^{\circ}\text{C}$

Humidity : $60 \pm 25\% \text{ RH.}$

9.2 SAMPLING PLAN

Sampling method shall be in accordance with MIL-STD-105E , level II, normal single sampling plan .

9.3 ACCEPTABLE QUALITY LEVEL

A major defect is defined as one that could cause failure to or materially reduce the usability of the unit for its intended purpose. A minor defect is one that does not materially reduce the usability of the unit for its intended purpose or is an infringement from established standards and has no significant bearing on its effective use or operation.

9.4 APPEARANCE

An appearance test should be conducted by human sight at approximately 30 cm distance from the LCD module under florescent light. The inspection area of LCD panel shall be within the range of following limits.

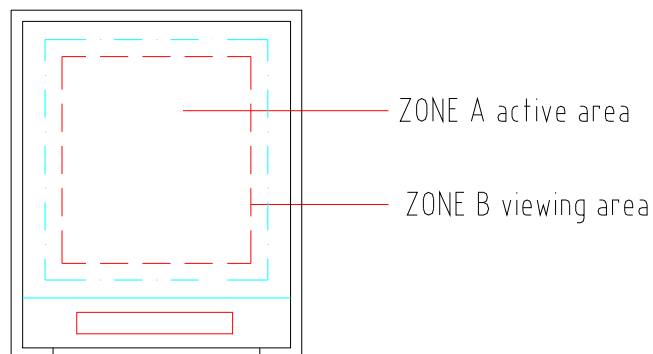

9.5 Incoming Inspection Standard

| Defect Type | | | Limit | | | Note | | |
|-------------------|--|------------------|--|--------------------|--------------------|--------------------|--------------------|-----|
| Visual Defect | Internal | Spot | $\phi < 0.15\text{mm}$ | Ignore | | (1) | | |
| | | | $0.15\text{mm} \leq \phi \leq 0.5\text{mm}$ | $N \leq 4$ | | | | |
| | | | $0.5\text{mm} < \phi$ | $N=0$ | | | | |
| | | Fiber | $0.1\text{mm} < W \leq 0.5\text{mm},$ $L \leq 1.5\text{mm}$ | $N \leq 4$ | | (1) | | |
| | | | $1.0\text{mm} < W, 1.5\text{mm} < L$ | $N=0$ | | | | |
| | | Polarizer Bubble | $\phi < 0.15\text{mm}$ | Ignore | | (1) | | |
| | $0.15\text{mm} \leq \phi \leq 0.5\text{mm}$ | | $N \leq 4$ | | | | | |
| | $0.5\text{mm} < \phi$ | | $N=0$ | | | | | |
| Mura | It' OK if mura is slight visible through 6%ND filter | | | | | | | |
| Electrical Defect | Bright Dot | A Grade | | | B Grade | | | |
| | | C Area | O Area | Total | C Area | O Area | Total | (3) |
| | | $N \leq 0$ | $N \leq 2$ | $N \leq 2$ | $N \leq 2$ | $N \leq 3$ | $N \leq 5$ | (2) |
| | Dark Dot | $N \leq 2$ | $N \leq 4$ | $N \leq 4$ | $N \leq 3$ | $N \leq 5$ | $N \leq 8$ | |
| | Total Dot | $N \leq 4$ | | | $N \leq 5$ | $N \leq 6$ | $N \leq 8$ | (2) |
| | Two Adjacent Dot | $N \leq 0$ | $N \leq 1$ pair | $N \leq 1$ pair | $N \leq 1$ pair | $N \leq 1$ pair | $N \leq 1$ pair | (4) |
| | Three or More Adjacent Dot | Not Allowed | | | | | | |
| | Line Defect | Not Allowed | | | | | | |

(1) One pixel consists of 3 sub-pixels, including R,G, and B dot.(Sub-pixel = Dot)

(2) LITTLE BRIGHT DOT acceptable under 6% ND-Filter

[Note1] W : Width[mm], L : Length[mm], N : Number, ϕ : Average Diameter

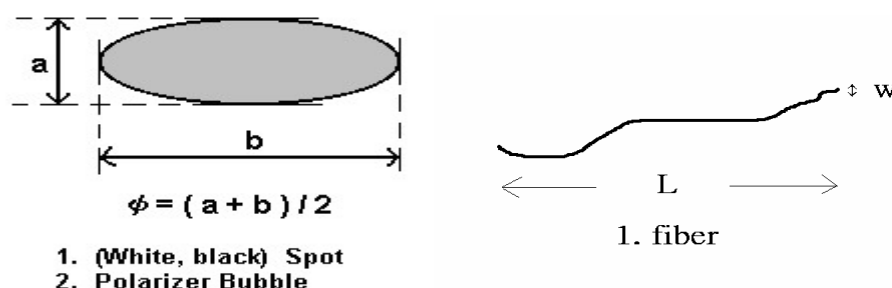

[Note2] Bright dot is defined through 6% transmission ND Filter as following.

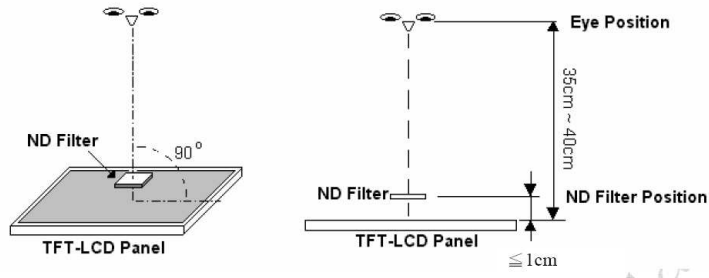

[Note3]

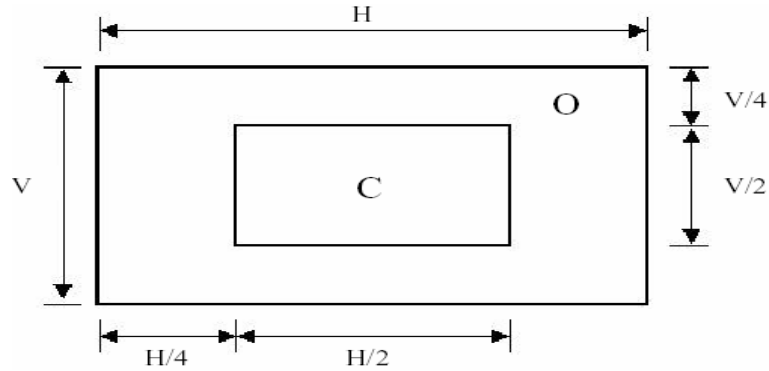

C Area: Center of display area

O Area: Outer of display area

[Note4]

Judge defect dot and adjacent dot as following. Allow below (as A, B, C and D status) adjacent defect dots, including bright and dark adjacent dot. And they will be counted 2 defect dots in total quantity.

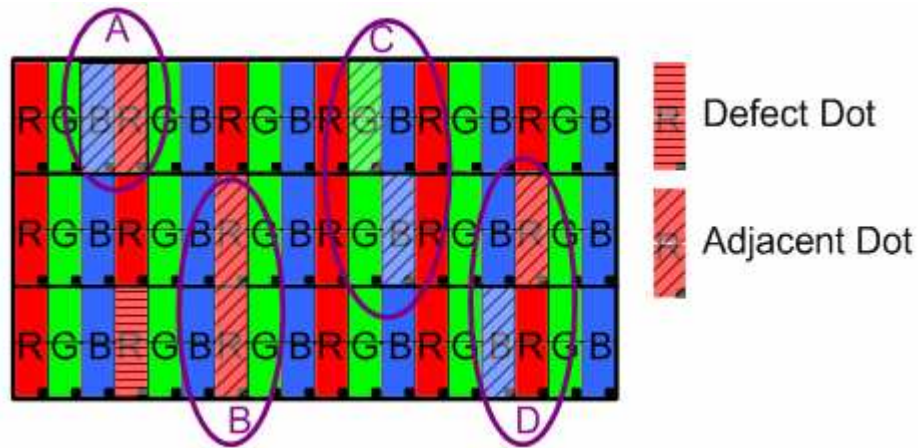

- (1) The defects that are not defined above and considered to be problem shall be reviewed and discussed by both parties.
- (2) Defects on the Black Matrix, out of Display area, are not considered as a defect or counted.

9.6 RELIABILITY TEST CONDITIONS

| Test Item | Test Conditions | Note |
|----------------------------|---|------|
| High Temperature Operation | 70±3°C ,Dry t=240 hrs | |
| Low Temperature Operation | -20±3°C, Dry t=240 hrs | |
| High Temperature Storage | 80±3°C , Dry t=240 hrs | 1,2 |
| Low Temperature Storage | -30±3°C ,Dry t=240 hrs | 1,2 |
| Thermal Shock Test | -20°C ~ 25°C ~ 70°C 30 m in. 5 min. 30 min. (1 cycle) Total 100 cycle(Dry) | 1,2 |
| Humidity Test | 40 °C, Humidity 90%, 240 hrs | 1,2 |
| Vibration Test (Packing) | Sweep frequency : 10 ~ 55 ~ 10 Hz/1min Amplitude : 0.75mm Test direction : X.Y.Z/3 axis Duration : 30min/each axis | 2 |

Note 1 : Condensation of water is not permitted on the module.

Note 2 : The module should be inspected after 1 hour storage in normal conditions

(15-35°C , 45-65%RH).

Definitions of life end point :

- Current drain should be smaller than the specific value.
- Function of the module should be maintained.
- Appearance and display quality should not have degraded noticeably.
- Contrast ratio should be greater than 50% of the initial value.

10. USE PRECAUTIONS

10.1 Handling precautions

- 1) The polarizing plate may break easily so be careful when handling it. Do not touch, press or rub it with a hard-material tool like tweezers.
- 2) Do not touch the polarizing plate surface with bare hands so as not to make it dirty. If the surface or other related part of the polarizing plate is dirty, soak a soft cotton cloth or chamois leather in benzine and wipe off with it. Do not use chemical liquids such as acetone, toluene and isopropyl alcohol. Failure to do so may bring chemical reaction phenomena and deteriorations.
- 3) Remove any spit or water immediately. If it is left for hours, the suffered part may deform or decolorize.
- 4) If the LCD element breaks and any LC stuff leaks, do not suck or lick it. Also if LC stuff is stuck on your skin or clothing, wash thoroughly with soap and water immediately.

10.2 Installing precautions

- 1) The PCB has many ICs that may be damaged easily by static electricity. To prevent breaking by static electricity from the human body and clothing, earth the human body properly using the high resistance and discharge static electricity during the operation. In this case, however, the resistance value should be approx. $1M\Omega$ and the resistance should be placed near the human body rather than the ground surface. When the indoor space is dry, static electricity may occur easily so be careful. We recommend the indoor space should be kept with humidity of 60% or more. When a soldering iron or other similar tool is used for assembly, be sure to earth it.
- 2) When installing the module and ICs, do not bend or twist them. Failure to do so may crack LC element and cause circuit failure.
- 3) To protect LC element, especially polarizing plate, use a transparent protective plate (e.g., acrylic plate, glass etc) for the product case.
- 4) Do not use an adhesive like a both-side adhesive tape to make LCD surface (polarizing plate) and product case stick together. Failure to do so may cause the polarizing plate to peel off.

10.3 Storage precautions

- 1) Avoid a high temperature and humidity area. Keep the temperature between 0°C and 35°C and also the humidity under 60%.
- 2) Choose the dark spaces where the product is not exposed to direct sunlight or fluorescent light.
- 3) Store the products as they are put in the boxes provided from us or in the same conditions as we recommend.

10.4 Operating precautions

- 1) Do not boost the applied drive voltage abnormally. Failure to do so may break ICs. When applying power voltage, check the electrical features beforehand and be careful. Always turn off the power to the LC module controller before removing or inserting the LC module input connector. If the input connector is removed or inserted while the power is turned on, the LC module internal circuit may break.
- 2) The display response may be late if the operating temperature is under the normal standard, and the display may be out of order if it is above the normal standard. But this is not a failure; this will be restored if it is within the normal standard.
- 3) The LCD contrast varies depending on the visual angle, ambient temperature, power voltage etc. Obtain the optimum contrast by adjusting the LC drive voltage.
- 4) When carrying out the test, do not take the module out of the low-temperature space suddenly. Failure to do so will cause the module condensing, leading to malfunctions.
- 5) Make certain that each signal noise level is within the standard (L level: 0.2V_{dd} or less and H level: 0.8V_{dd} or more) even if the module has functioned properly. If it is beyond the standard, the module may often malfunction. In addition, always connect the module when making noise level measurements.
- 6) The CMOS ICs are incorporated in the module and the pull-up and pull-down function is not adopted for the input so avoid putting the input signal open while the power is ON.
- 7) The characteristic of the semiconductor element changes when it is exposed to light emissions, therefore ICs on the LCD may malfunction if they receive light emissions. To prevent these malfunctions, design and assemble ICs so that they are shielded from light emissions.
- 8) Crosstalk occurs because of characteristics of the LCD. In general, crosstalk occurs when the regularized display is maintained. Also, crosstalk is affected by the LC drive voltage. Design the contents of the display, considering crosstalk.

10.5 Other

- 1) Do not disassemble or take the LC module into pieces. The LC modules once disassembled or taken into pieces are not the guarantee articles.
- 2) The residual image may exist if the same display pattern is shown for hours. This residual image, however, disappears when another display pattern is shown or the drive is interrupted and left for a while. But this is not a problem on reliability.
- 3) AMIPRE will provide one year warranty for all products and three months warranty for all repairing products.

11. OUTLINE DIMENSION

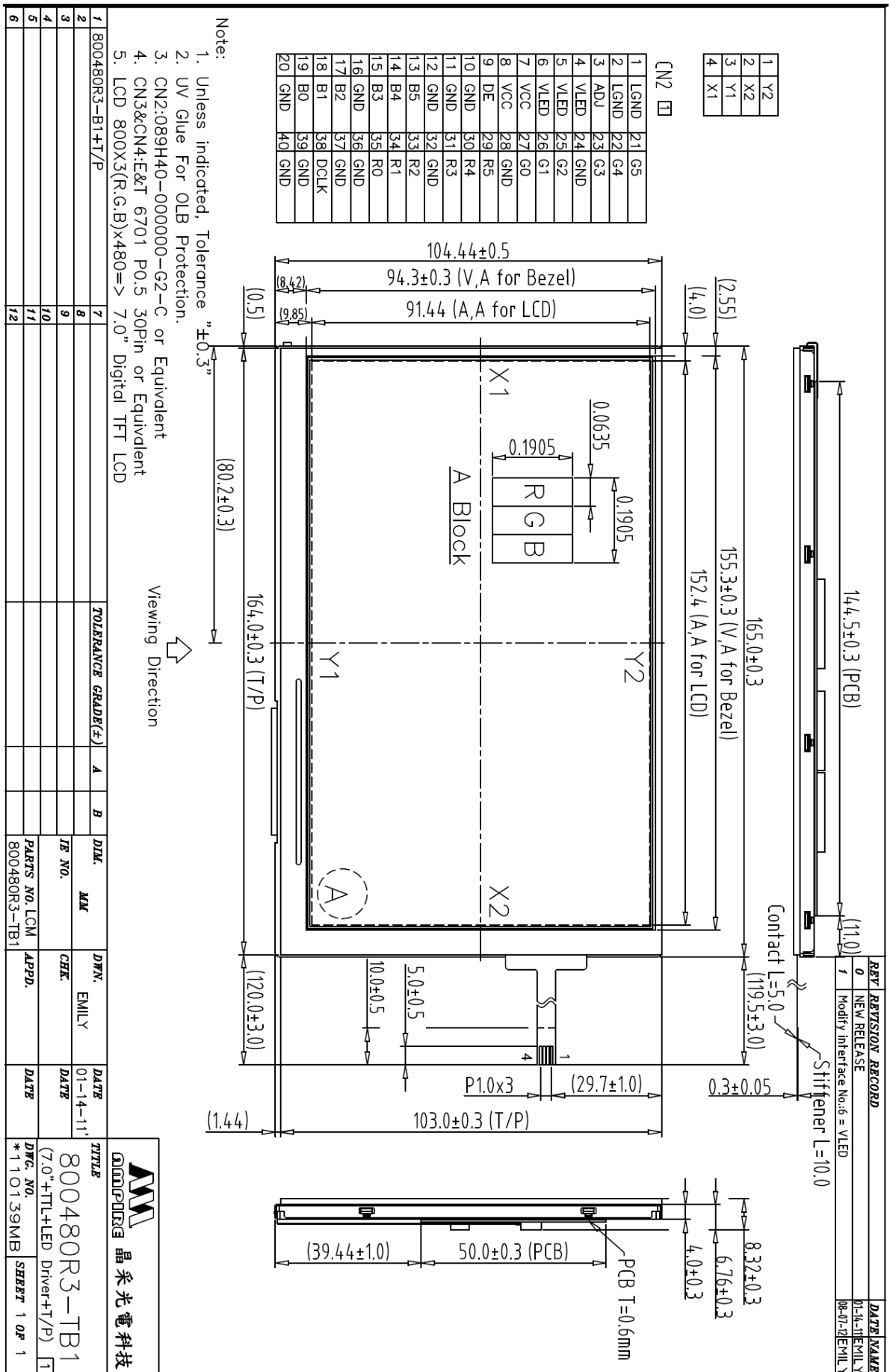

| REV | REVISION RECORD | DATE NAME |
|-----|------------------------------|---------------|
| 0 | NEW RELEASE | 01-14-11EMILY |
| 1 | Modify Interface No.6 = VLED | 08-07-12EMILY |

| | |
|---|----|
| 1 | Y2 |
| 2 | X2 |
| 3 | Y1 |
| 4 | X1 |

| | | | |
|----|------|----|------|
| 1 | LGND | 21 | G5 |
| 2 | LGND | 22 | G4 |
| 3 | ADJ | 23 | G3 |
| 4 | VLED | 24 | GND |
| 5 | VLED | 25 | G2 |
| 6 | VLED | 26 | G1 |
| 7 | VCC | 27 | G0 |
| 8 | VCC | 28 | GND |
| 9 | DE | 29 | R5 |
| 10 | GND | 30 | R4 |
| 11 | GND | 31 | R3 |
| 12 | GND | 32 | GND |
| 13 | B5 | 33 | R2 |
| 14 | B4 | 34 | R1 |
| 15 | B3 | 35 | R0 |
| 16 | GND | 36 | GND |
| 17 | B2 | 37 | GND |
| 18 | B1 | 38 | DCLK |
| 19 | B0 | 39 | GND |
| 20 | GND | 40 | GND |

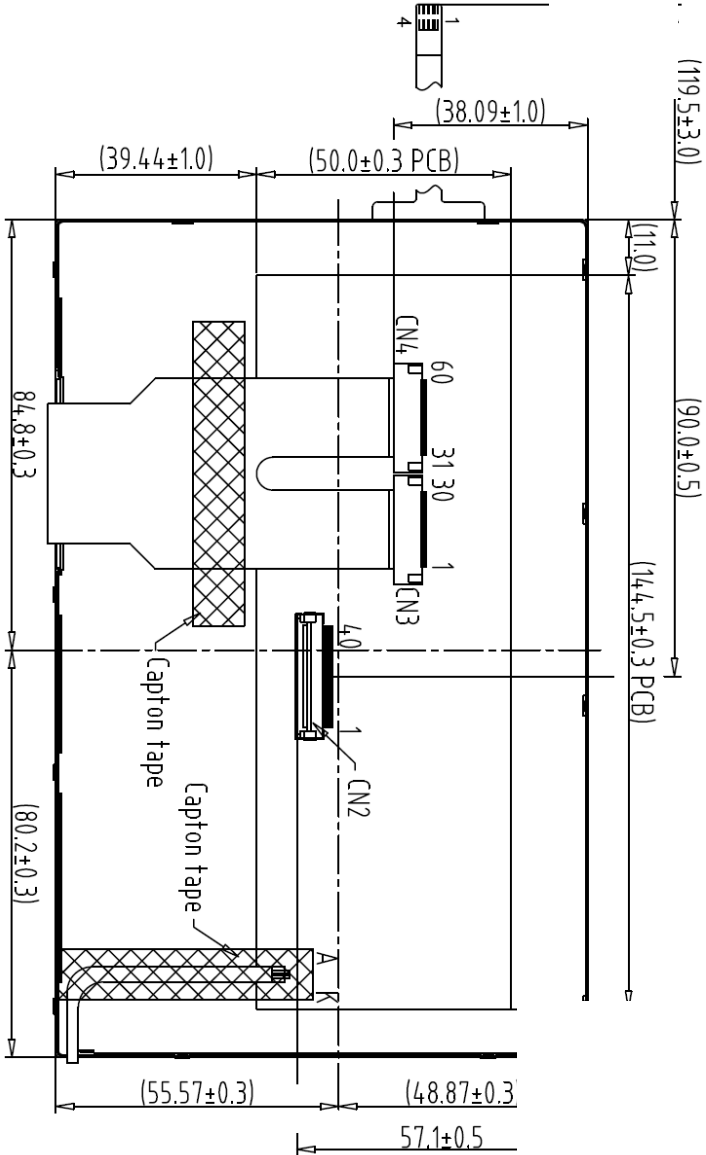

Back View

- Note:
1. Unless indicated, Tolerance "±0.3"
 2. UV Glue For OLB Protection.
 3. CN2:089H40-000000-G2-C or Equivalent
 4. CN3&CN4:E&T 6701 P0.5 30Pin or Equivalent
 5. LCD 800X3(R.G.B)x480=> 7.0" Digital TFT LCD

| | | | | | | | | | | | | |
|---|-----------------|----|--|--------------------|---|---|--------------|-------|-------|-------|------|---------------------------|
| 1 | 800480R3-B1+T/P | 7 | | TOLERANCE GRADE(F) | A | B | DIM. | MM | DWN. | EMILY | DATE | TITLE |
| 2 | | 8 | | | | | IE NO. | | CHEK. | | DATE | 800480R3-TB1 |
| 3 | | 9 | | | | | PARTS NO. | LCM-1 | APPD. | | DATE | (7.0"+TTL+LED Driver+T/P) |
| 4 | | 10 | | | | | 800480R3-TB1 | | | | DATE | *110140MB |
| 5 | | 11 | | | | | | | | | DATE | SHEET 1 OF 1 |
| 6 | | 12 | | | | | | | | | DATE | |

AMPIRE 晶采光電科技