



晶采光電科技股份有限公司  
AMPIRE CO., LTD.

## SPECIFICATIONS FOR LCD MODULE

<b>CUSTOMER</b>	
<b>CUSTOMER PART NO.</b>	
<b>AMPIRE PART NO.</b>	<b>AM-800480C1TZQW-TAGH</b>
<b>APPROVED BY</b>	
<b>DATE</b>	

Preliminary Specification

Formal Specification

**AMPIRE CO., LTD.**

**4F., No.116, Sec. 1, Xintai 5th Rd., Xizhi Dist., New Taipei City221,  
Taiwan (R.O.C.)**

**新北市汐止區新台五路一段 116 號 4 樓(東方科學園區 A 棟)**

APPROVED BY	CHECKED BY	ORGANIZED BY
Patrick	Lawlite	Kokai

This Specification is subject to change without notice.

## RECORD OF REVISION

Revision Date	Page	Contents	Editor
2021/06/7	--	New Release	Kokai

## 1.0 General Descriptions

7 inch Amorphous-TFT-LCD (Thin Film Transistor Liquid Crystal Display) module.

This module is composed of a 7" TFT-LCD panel and backlight unit.

### 1.1 Features

- 7 inch (16:9 diagonal) configuration
- 262K colors ( R , G , B, 6bit digital each)
- RoHS
  
- Projective Capacitive Touch
  - a. Interface : USB
  - b. Touch Controller :EXC80W32
  - c. Double sided tape between LCD and touch panel

## 1.2 Product Summary

NO	Item	Specification	Remark
1	LCD Size	7.0 inch (Diagonal)	
3	Resolution	800 x 3 (RGB) x 480	
4	Display Mode	Normally Black.	
5	Pixel pitch	0.1905 (W) x 0.1905(H) mm	
6	Active area	152.4(W) x 91.44(H) mm	
7	Module Size	165(W) x 104.4(H) x 12.615(T) mm	Note 1
8	interface	LVDS	
9	Color arrangement	RGB-stripe	
10	Luminance	425 cd/m <sup>2</sup>	cd/m <sup>2</sup>
11	Viewing Direction	All direction	

(Note1) Refer to the mechanical drawing.

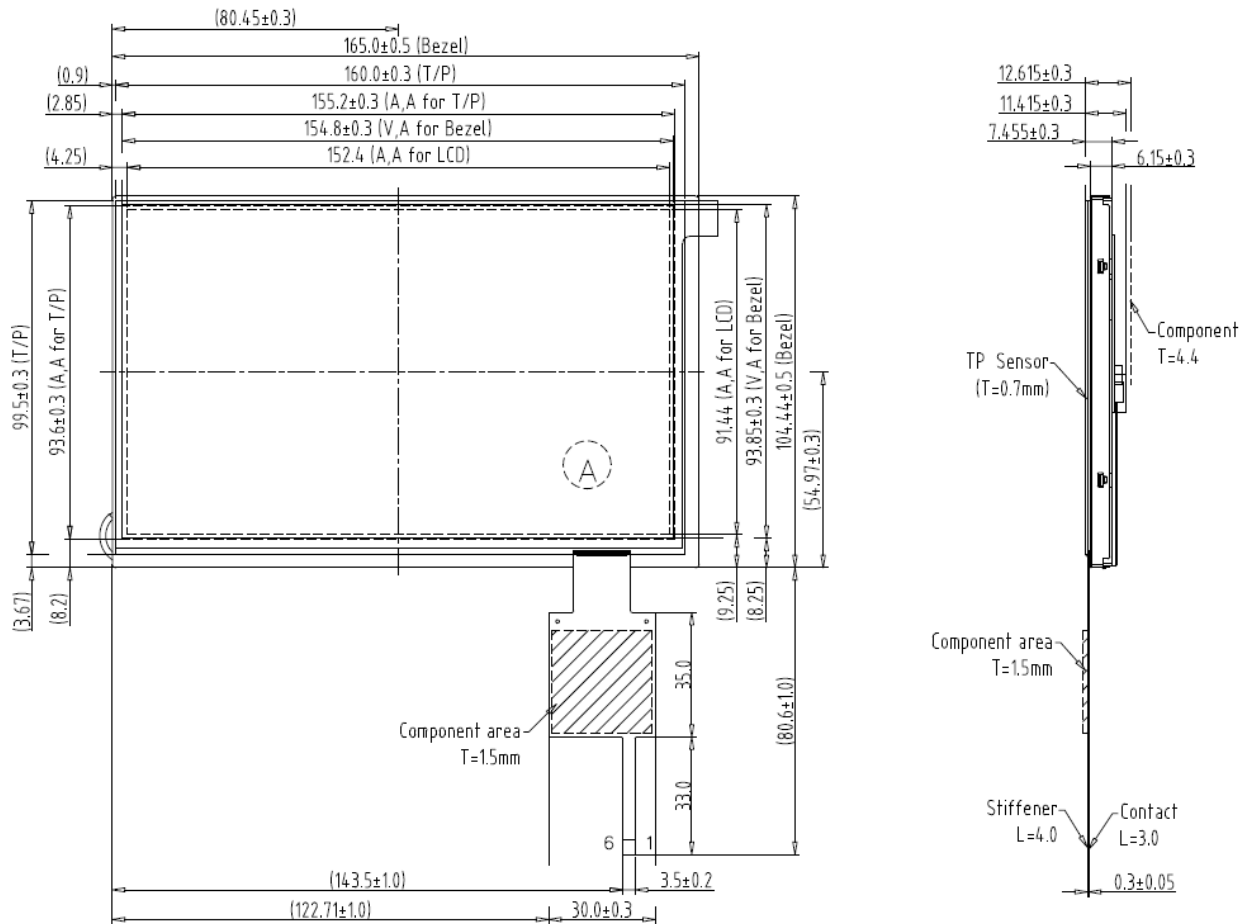

## 2.0 Absolute Maximum Ratings

Item	Symbol	Min.	Max.	Unit	Remakes
Supply Voltage	$V_{DD}$	-0.3	3.6	V	-
Input Voltage of Logic	$V_I$	-0.3	$V_{DD+0.3}$	V	Note 1
Operating Temperature	$T_{OP}$	-40	85	°C	Note 2
Storage Temperature	$T_{ST}$	-40	85	°C	Note 2

Note 1: The rating is defined for the signal voltages of the interface such as CLK and pixel data pairs.

Note2: The maximum rating is defined as above based on the chamber temperature, which might be different from ambient temperature after assembling the panel into the application. Moreover, some temperature-related phenomenon as below needed to be noticed:

- Background color, contrast and response time would be different in temperatures other than 25°C.
- Operating under high temperature will shorten LED lifetime.

### 3.0 ELECTRICAL CHARACTERISTICS

#### 3.1 LCD CHARACTERISTICS

Item	Symbol	Min.	Typ.	Max.	Unit	Note
LCD Supply Voltage	VDD	3.0	3.3	3.6	V	-
Logic Input Voltage	VIH	0.7VDD	-	VDD		
	VIL	GND	-	0.3VDD	V	
LCD Supply Current	ICC	-	180	-	mA	(1)
Power Supply Voltage For LED Driver	VLED	11.7	12	12.3	V	(1)
Power Supply Current For LED Driver	ILED	--	160	--	mA	VLED =12V
Differential Input High Threshold	VTH	-	-	+100	mV	VOC=+1.2V
Differential Input Low Threshold	VTL	-100	-	-	mV	

Note1: Ta=25°C , Display pattern : All White

### 3.2 BACKLIGHT CHARACTERISTICS

Item	Symbol	Min.	Typ.	Max.	Unit	Note
Input Voltage	VLED	11.7	12.0	12.3	V	
Input Current	ILED	--	T.B.D	--	mA	0% PWM duty
DIM Frequency	Fpwm	100		20K	Hz	
DIM Signal Logic High	VIH	1.2	--	3.3	V	
DIM signal logic Low	VIL	0	--	0.4	V	
LED Forward Current	IF	--	85	--	mA	Ta=25°C
LED Forward Voltage	VF	--	18	--	V	IF=85mA, Ta=25°C
LED life time			50,000	-	Hr	IF=85mA, Ta=25°C

- The constant current source is needed for white LED back-light driving.
- When LCM is operated over 40°C ambient temperature, the IF should be follow :

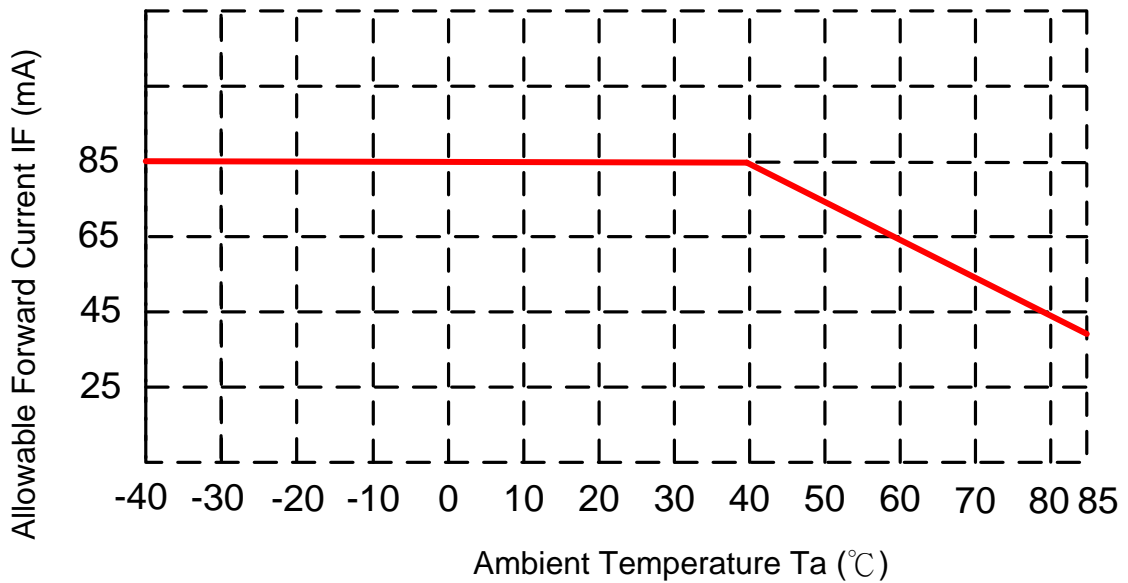

■ 6 LED Serial x 5 LED Parallel

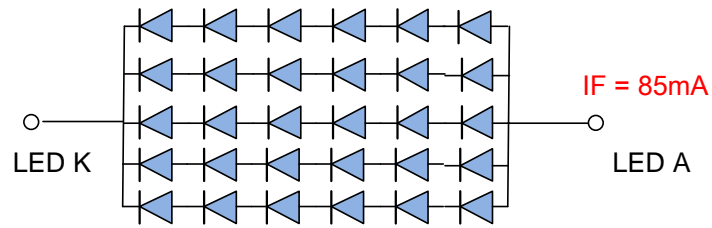

■ DIM Duty

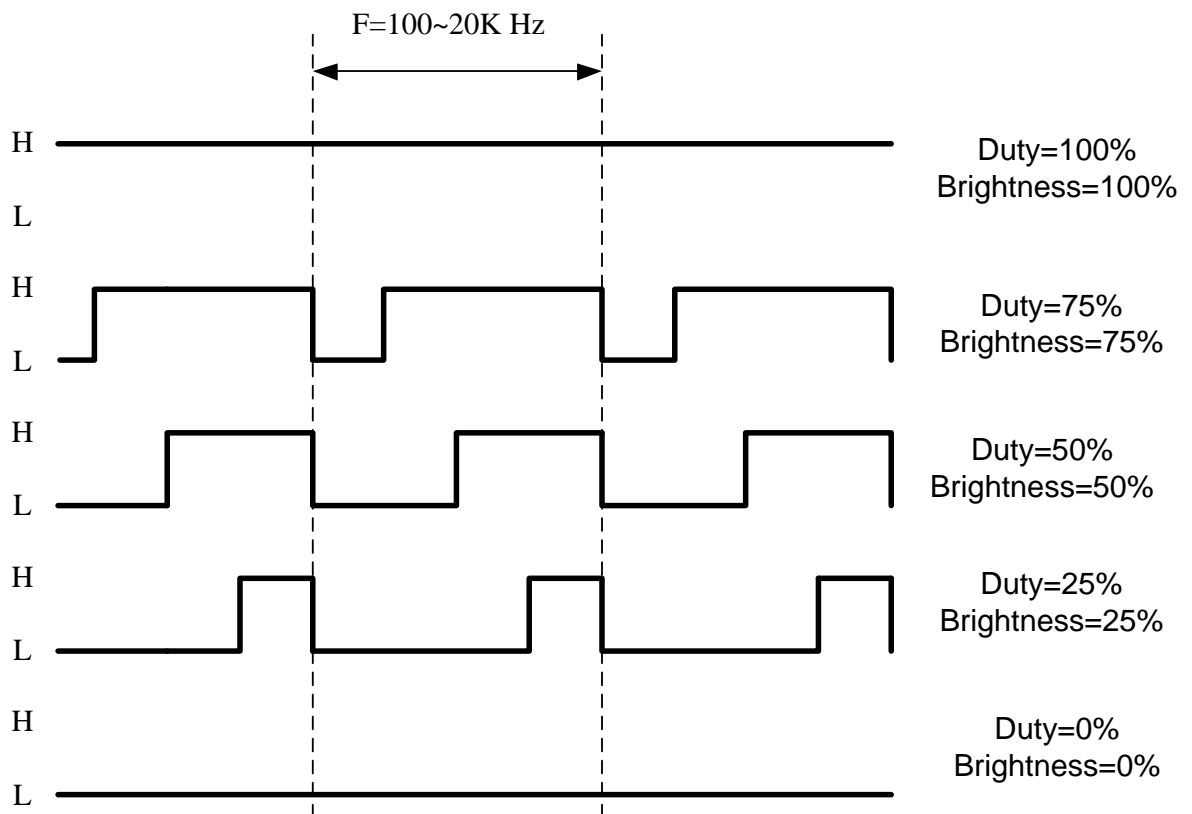

### 3.3 Touch Panel Unit

#### 3.3.1 Basic Characteristic

ITEM	SPECIFICATION
Type	Projective Capacitive Touch Panel
Activation	10-fingers or Signal-finger
X/Y Position Reporting	Absolute Position
Touch Force	No contact pressure required
Calibration	No need for calibration
Report Rate	Approx 100 points/sec
Interface	USB
Control IC	EXC80W32

Specify the normal operating condition

(GND=0V)

Item	Symbol	Min.	Typ.	Max.	Unit	Note
Power Supply Voltage	VIN	4.75	5.0	5.25	V	

#### 3.3.2 Interface

Pin No.	Symbol	Function
1	DGND	USB Power GND
2	DA-	USB Data-
3	DA+	USB Data+
4	VIN	USB Power 5V
5	NA	Non Use
6	NA	Non Use

#### Grounding

TP needs to work in environment with stable stray capacitance. In order to minimize the variation in stray capacitance, all conductive mechanical parts must not be floating. Intermittent floating any conductive part around the touch sensor may cause significant stray capacitance change and abnormal touch function. It is recommended to keep all conductive parts having same electrical potential as the GND of the touch controller module.

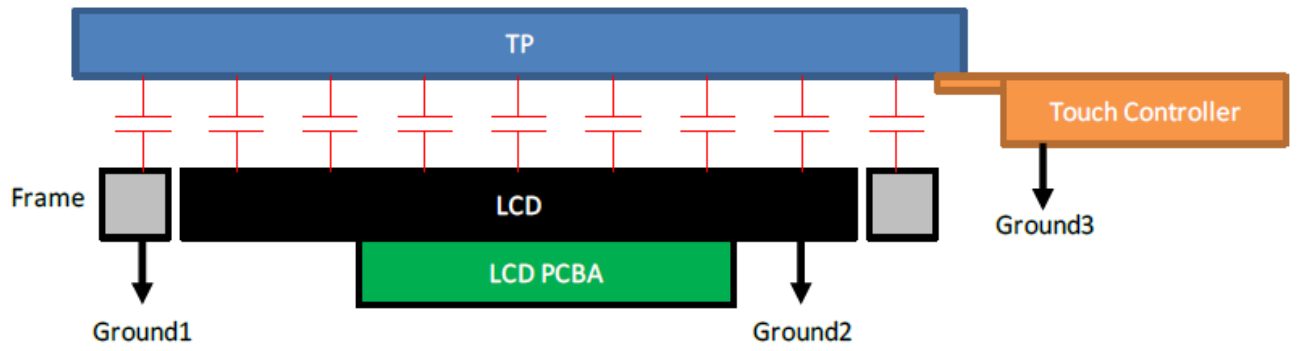

GND1, GND2 and GND3 should be connected together to have the same ground

## 4.0 TIMING

### 4.1 time table

#### HV mode for 800x480

Parameter	Symbol	Min.	Typ.	Max.	Unit
CLK frequency	$F_{CLK}$	25.2	25.4	35.7	MHz
Horizontal display area	$T_{HD}$		800		CLK
HS period time	$T_H$	860	864	974	CLK
HS pulse width	$T_{HPW}$	1	2	40	CLK
HS back porch	$T_{HBP}$		32		CLK
HS front porch	$T_{HFP}$	28	32	142	CLK
Vertical display area	$T_{VD}$		480		H
VS period time	$T_V$	488	490	611	H
VS pulse width	$T_{VPW}$	1	2	20	H
VS back porch	$T_{VBP}$		5		H
VS front porch	$T_{VFP}$	3	5	126	H

#### DE mode for 800x480

Parameter	Symbol	Min.	Typ.	Max.	Unit
CLK frequency	$F_{CLK}$	25.2	25.4	35.7	MHz
Horizontal display area	$T_{HD}$		800		CLK
HS period time	$T_H$	860	864	974	CLK
HS blanking	$T_{HFP} + T_{HBP}$	60	64	174	CLK
Vertical display area	$T_{VD}$		480		H
VS period time	$T_V$	488	490	611	H
VS blanking	$T_{VBP} + T_{VFP}$	8	10	131	H

## 4.2 LVDS receiver timing

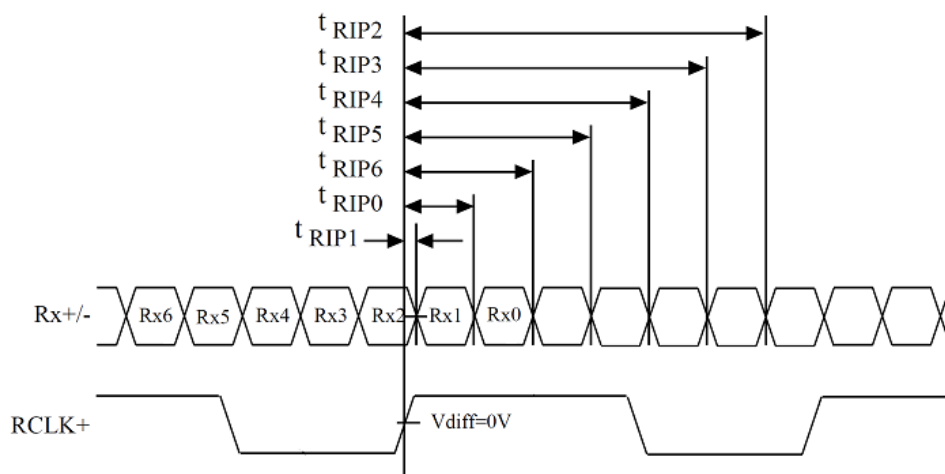

### Switching Characteristics

$V_{cc} = 3.0 - 3.6V$ ,  $T_a = -10 - +70\text{ }^\circ\text{C}$

#### RECEIVER

$t_{RCP}$	CLK OUT Period	11.76	T	50.0	ns
$t_{RCH}$	CLK OUT High Time		$4T/7$		ns
$t_{RCL}$	CLK OUT Low Time		$3T/7$		ns
$t_{RCD}$	RCLK+/- to CLK OUT Delay		$5T/7$		ns
$t_{RS}$	TTL Data Setup to CLK OUT	$3T/7-2.5$			ns
$t_{RH}$	TTL Data Hold from CLK OUT	$4T/7-3.5$			ns
$t_{TLH}$	TTL Low to High Transition Time		3.0	5.0	ns
$t_{THL}$	TTL High to Low Transition Time		3.0	5.0	ns
$t_{RIP1}$	Input Data Position 0 (T=11.76ns)	-0.4	0.0	0.4	ns
$t_{RIP0}$	Input Data Position 1 (T=11.76ns)	$T/7-0.4$	$T/7$	$T/7+0.4$	ns
$t_{RIP6}$	Input Data Position 2 (T=11.76ns)	$2T/7-0.4$	$2T/7$	$2T/7+0.4$	ns
$t_{RIP5}$	Input Data Position 3 (T=11.76ns)	$3T/7-0.4$	$3T/7$	$3T/7+0.4$	ns
$t_{RIP4}$	Input Data Position 4 (T=11.76ns)	$4T/7-0.4$	$4T/7$	$4T/7+0.4$	ns
$t_{RIP3}$	Input Data Position 5 (T=11.76ns)	$5T/7-0.4$	$5T/7$	$5T/7+0.4$	ns
$t_{RIP2}$	Input Data Position 6 (T=11.76ns)	$6T/7-0.4$	$6T/7$	$6T/7+0.4$	ns
$t_{RPLL}$	Phase Lock Loop Set			10.0	ms

### 4.3 Power On / Off Sequence

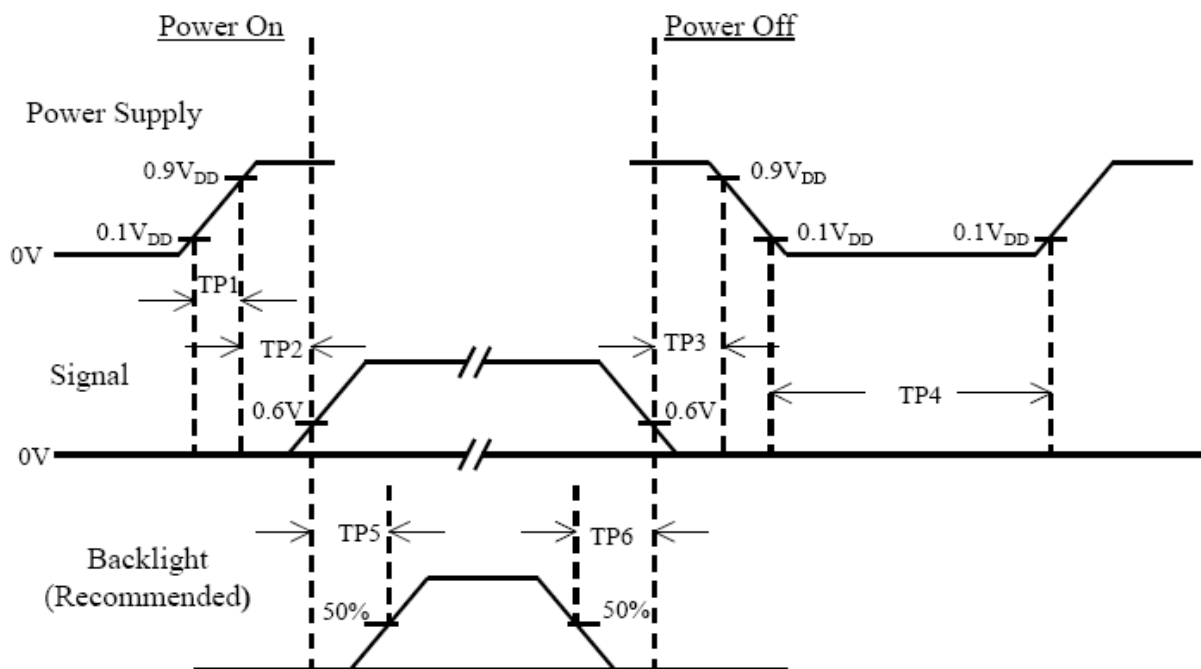

Item	Min.	Typ.	Max.	Unit	Remark
TP1	0.5	--	10	msec	
TP2	0	--	50	msec	
TP3	0	--	50	msec	
TP4	500	--	--	msec	
TP5	200	--	--	msec	
TP6	200	--	--	msec	

Note :

- (1) The supply voltage of the external system for the module input should be the same as the definition of VDD.
- (2) Apply the lamp voltage within the LCD operation range. When the back-light turns on before the LCD operation or the LCD turns off before the back-light turns off, the display may momentarily become white.
- (3) In case of VDD = off level, please keep the level of input signal on the low or keep a high impedance.
- (4) TP4 should be measured after the module has been fully discharged between power off and on period.
- (5) Interface signal shall not be kept at high impedance when the power is on.

## 5.0 LVDS DATA FORMAT

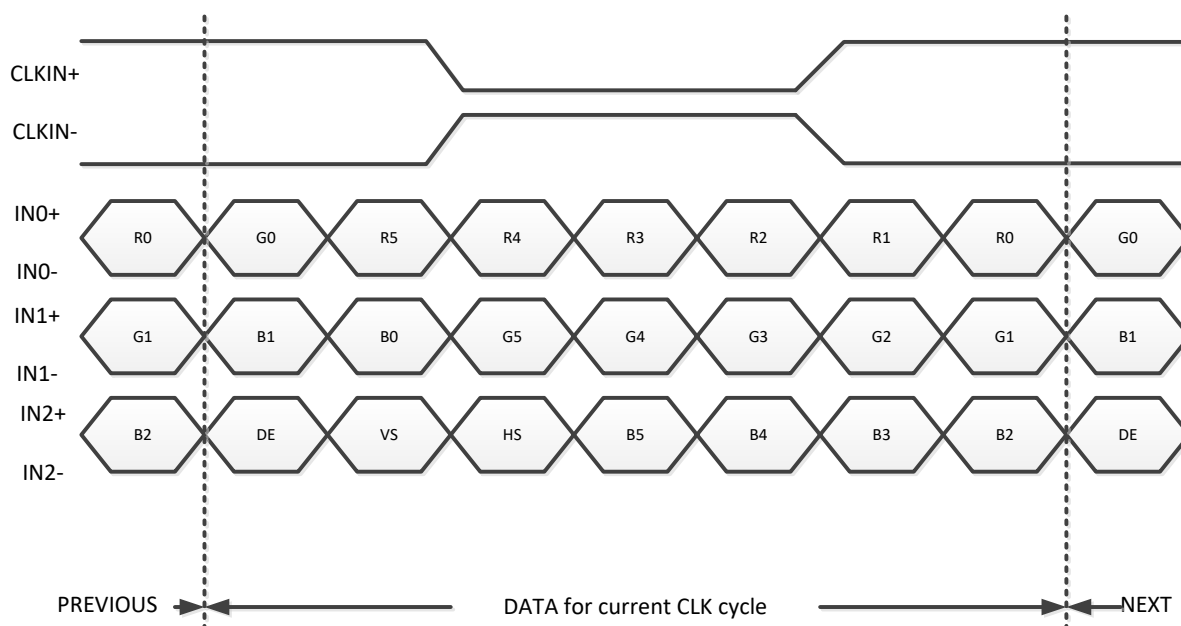

Note : R/G/B data 6 : MSB, R/G/B data 0 : LSB

Signal Name	Description	Remark
R5 R4 R3 R2 R1 R0	Red Data 5 (MSB) Red Data 4 Red Data 3 Red Data 2 Red Data 1 Red Data 0 (LSB)	Red-pixel Data Each red pixel's brightness data consists of these 6 bits pixel data.
G5 G4 G3 G2 G1 G0	Green Date 5 (MSB) Green Date 4 Green Date 3 Green Date 2 Green Date 1 Green Date 0 (LSB)	Green-pixel Data Each green pixel's brightness data consists of these 6 bits pixel data.
B5 B4 B3 B2 B1 B0	Blue Data 5(MSB) Blue Data 4 Blue Data 3 Blue Data 2 Blue Data 1 Blue Data 0 (LSB)	Blue-pixel Data Each blue pixel's brightness data consists of these 6 bits pixel data.
CLKIN+ CLKIN-	LVDS Clock Input	
DE	Display Enable	
VS	Vertical Sync Signal	
HS	Horizontal Sync Signal	

## 6.0 INTERFACE

Pin No.	Symbol	I/O	Description	Note
1	VDD	P	Power Voltage for Logic: 3.3V	
2	VDD	P	Power Voltage for Logic: 3.3V	
3	GND	P	Ground	
4	GND	P	Ground	
5	IN0-	I	- LVDS differential data input	
6	IN0+	I	+ LVDS differential data input	
7	GND	P	Ground	
8	IN1-	I	- LVDS differential data input	
9	IN1+	I	+ LVDS differential data input	
10	GND	P	Ground	
11	IN2-	I	- LVDS differential data input	
12	IN2+	I	+ LVDS differential data input	
13	GND	P	Ground	
14	CLK-	I	- LVDS differential data input	
15	CLK+	I	+ LVDS differential data input	
16	GND	P	Ground	
17	VLED	I	POWER SUPPLY for Backlight	
18	VLED	I	POWER SUPPLY for Backlight	
19	GND	P	Ground	
20	ADJ	P	PWM duty 0% to 100%	

## 7.0 Optical Specifications

### 7.1 TFT Optical Characteristics

Item	Symbol	Conditio	Min	Typ	Max	Unit	Remark	
View Angles	$\theta T$	$CR \geq 10$		80	-	Degree	Note 2	
	$\theta B$			80	-			
	$\theta L$			80	-			
	$\theta R$			80	-			
Contrast Ratio	CR	$\theta=0^\circ$	800	1000	-		Left/right $0^\circ$ Top/bottom $5^\circ$	
Response Time	$T_{ON}+T_{OFF}$	$25^\circ C$	-	25	35	ms	Note1 Note4	
Chromaticity	White	x	-0.05	0.328	+0.05		Note5 Note1	
		y						0.347
	Red	x						0.615
		y						0.321
	Green	x						0.310
		y						0.563
	Blue	x						0.136
		y						0.098
Uniformity	U		70	--	-	%	Note1 · Note6	
Luminance	L		340	425	-	cd/m <sup>2</sup>	Note7	

Test Conditions:

1. VLED=12V , ADJ PWM Duty=100% , the ambient temperature is  $25^\circ C$ .
2. The test systems refer to Note 1 and Note2.

Note 1: Definition of optical measurement system.

The optical characteristics should be measured in dark room. After 10 Minutes operation, the optical properties are measured at the center point of the LCD screen. All input terminals LCD panel must be ground when measuring the center area of the panel.

Note 1 : Definition of optical measurement system.

The optical characteristics should be measured in dark room. After 30 minutes operation, the optical properties are measured at the center point of the LCD screen. (Response time is measured by Photo detector TOPCON BM-7, other items are measured by BM-5A/Field of view : 1° / Height : 500mm.)

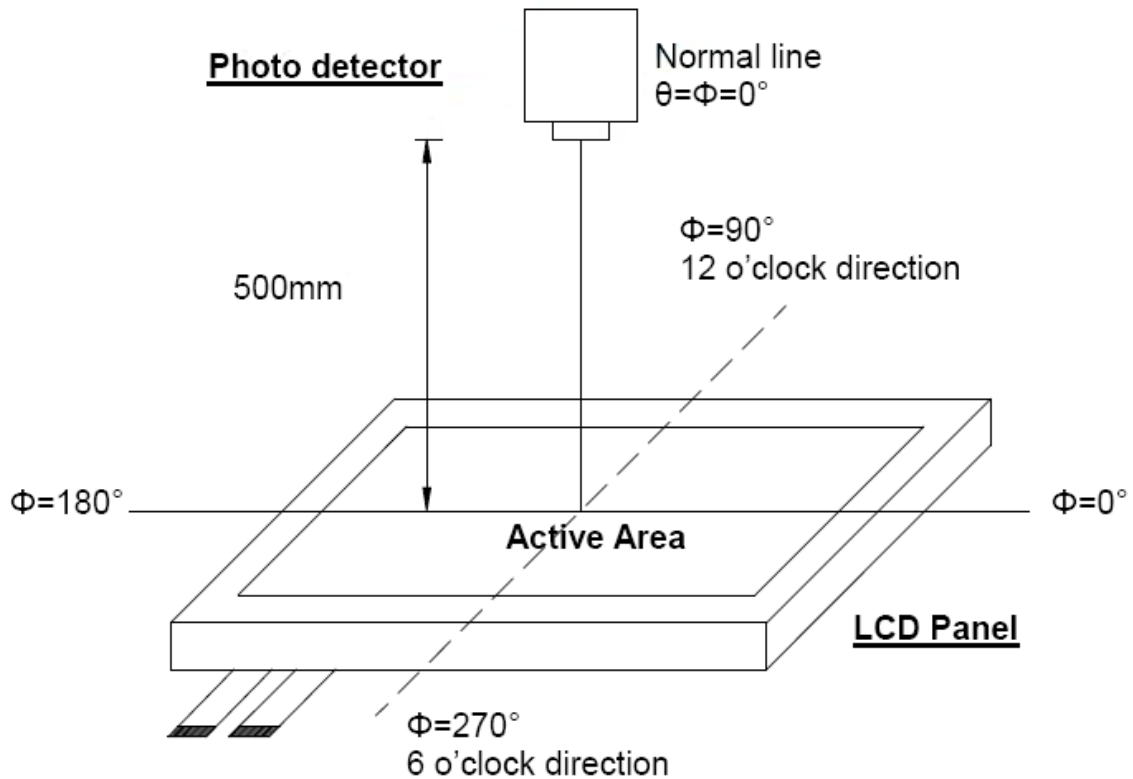

Note

2 : Definition of viewing angle range

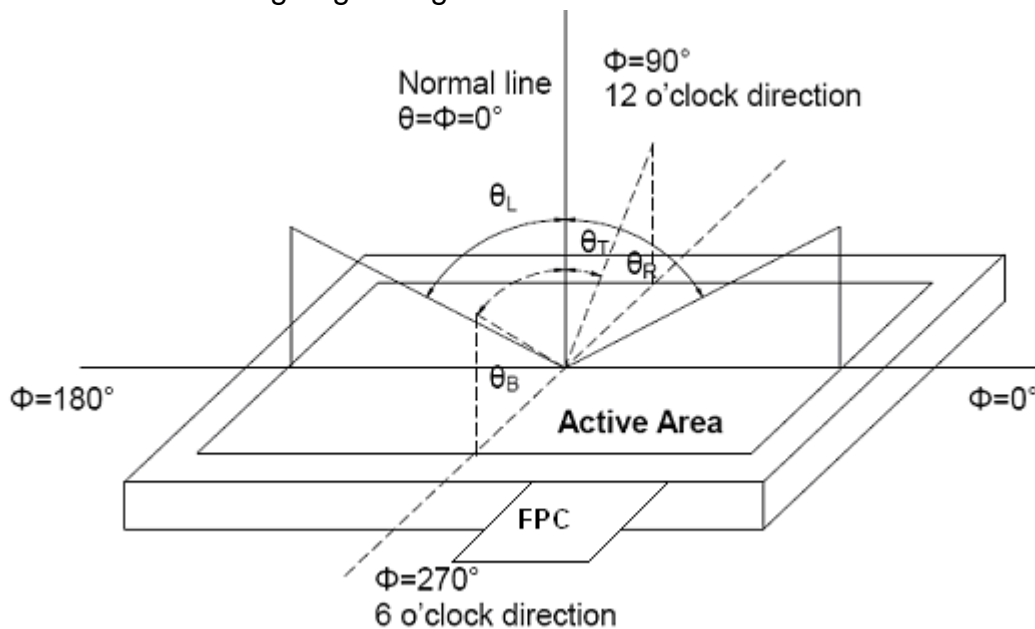

Note 3 : Definition of Response time

The response time is defined as the LCD optical switching time interval between “White” state and “Black” state. Rise time (T<sub>ON</sub>) is the time between photo detector output intensity changed from 90% to 10%. And fall time (T<sub>OFF</sub>) is the time between photo detector output intensity changed from 10% to 90%.

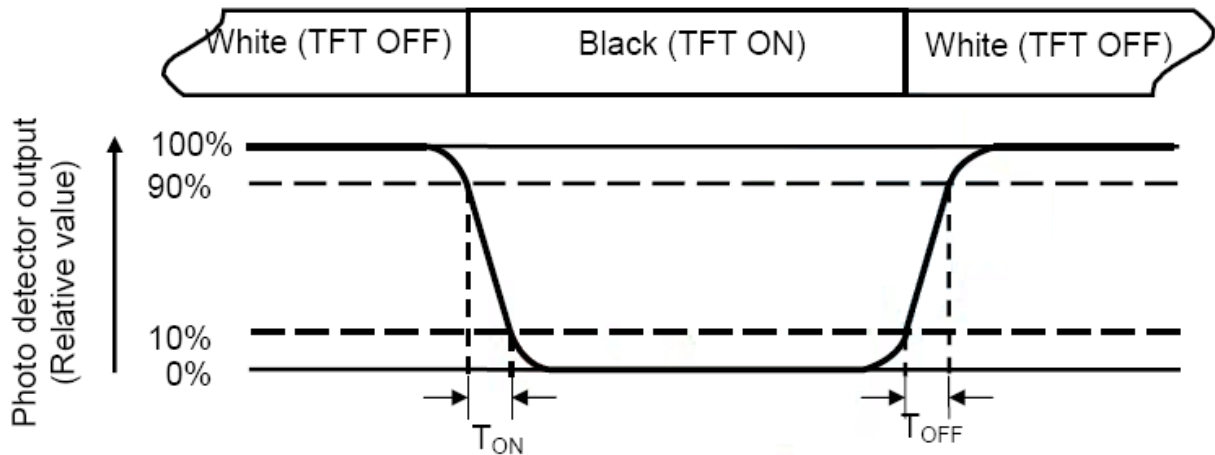

Note 4 : Definition of contrast ratio

$$\text{Contrast ratio (CR)} = \frac{\text{Luminance measured when LCD on the "White" state}}{\text{Luminance measured when LCD on the "Black" state}}$$

Note 5 : Definition of color chromaticity (CIE1931)

Color coordinated measured at center point of LCD.

Note 6 : All input terminals LCD panel must be ground when measuring the center area of the panel.

Note 7 : Definition of Luminance Uniformity

Active area is divided into 9 measuring areas (Refer to bellow figure). Every measuring point is placed at the center of each measuring area.

$$\text{Luminance Uniformity (Yu)} = \frac{B_{\min}}{B_{\max}}$$

L ----- Active area length      W ----- Active area width

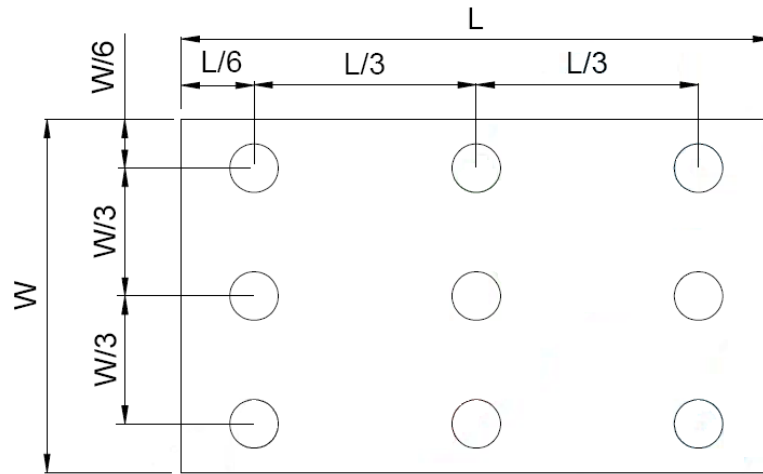

$B_{\max}$  : The measured maximum luminance of all measurement position.

$B_{\min}$  : The measured minimum luminance of all measurement position.

## 8.0 Reliability Test Items

Test Item	Test Conditions	Note
High Temperature Operation	85±3°C , t=240 hrs	
Low Temperature Operation	-40±3°C , t=240 hrs	
High Temperature Storage	85±3°C , t=240 hrs	1,2
Low Temperature Storage	-40±3°C , t=240 hrs	1,2
Storage at High Temperature and Humidity	40°C, 85% RH , 240 hrs	1,2
Thermal Shock Test	-40°C (30min) ~ 85°C (30min) 50 cycles	1,2
Vibration Test (Packing)	Sweep frequency : 10 ~ 55 ~ 10 Hz/1min Amplitude : 0.75mm Test direction : X.Y.Z/3 axis Duration : 30min/each axis	2

Note 1 : Condensation of water is not permitted on the module.

Note 2 : The module should be inspected after 1 hour storage in normal conditions (15-35°C , 45-65%RH).

Note 3 : The module shouldn't be tested more than one condition, and all the test conditions are independent.

Note 4 : All the reliability tests should be done without protective film on the module.

Definitions of life end point :

- Current drain should be smaller than the specific value.
- Function of the module should be maintained.
- Appearance and display quality should not have degraded noticeably.
- Contrast ratio should be greater than 50% of the initial value.

## **9. GENERAL PRECAUTION**

### **9.1 Use Restriction**

This product is not authorized for use in life supporting systems, aircraft navigation control systems, military systems and any other application where performance failure could be life-threatening or otherwise catastrophic.

### **9.2 Disassembling or Modification**

Do not disassemble or modify the module. It may damage sensitive parts inside LCD module, and may cause scratches or dust on the display. AMPIRE does not warrant the module, if customers disassemble or modify the module.

### **9.3 Breakage of LCD Panel**

- (1) If LCD panel is broken and liquid crystal spills out, do not ingest or inhale liquid crystal, and do not contact liquid crystal with skin.
- (2) If liquid crystal contacts mouth or eyes, rinse out with water immediately.
- (3) If liquid crystal contacts skin or cloths, wash it off immediately with alcohol and rinse thoroughly with water.
- (4) Handle carefully with chips of glass that may cause injury, when the glass is broken.

### **9.4 Electric Shock**

- (1) Disconnect power supply before handling LCD module.
- (2) Do not pull or fold the LED cable.
- (3) Do not touch the parts inside LCD modules and the fluorescent LED's connector or cables in order to prevent electric shock.

### **9.5 Absolute Maximum Ratings and Power Protection Circuit**

- (1) Do not exceed the absolute maximum rating values, such as the supply voltage variation, input voltage variation, variation in parts' parameters, environmental temperature, etc., otherwise LCD module may be damaged.
- (2) Please do not leave LCD module in the environment of high humidity and high temperature for a long time.
- (3) It's recommended to employ protection circuit for power supply.

### **9.6 Operation**

- (1) Do not touch, push or rub the polarizer with anything harder than HB pencil lead.

- (2) Use fingerstalls of soft gloves in order to keep clean display quality, when persons handle the LCD module for incoming inspection or assembly.
- (3) When the surface is dusty, please wipe gently with absorbent cotton or other soft material.
- (4) Wipe off saliva or water drops as soon as possible. If saliva or water drops contact with polarizer for a long time, they may cause deformation or color fading.
- (5) When cleaning the adhesives, please use absorbent cotton wetted with a little petroleum benzene or other adequate solvent.

### 9.7 Mechanism

- (1) Please mount LCD module by using mounting holes arranged in four corners tightly.
- (2) The square adhesive tape which is between the touch panel and display can't provide well supporting in the long term and high ambient temperature condition. Whether upright or horizontal position the support holder which is in the back side of the display is needed. Do not let the display floating.

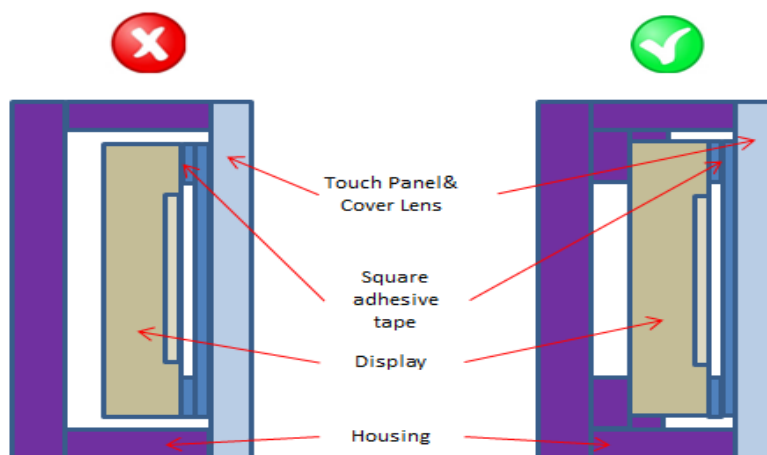
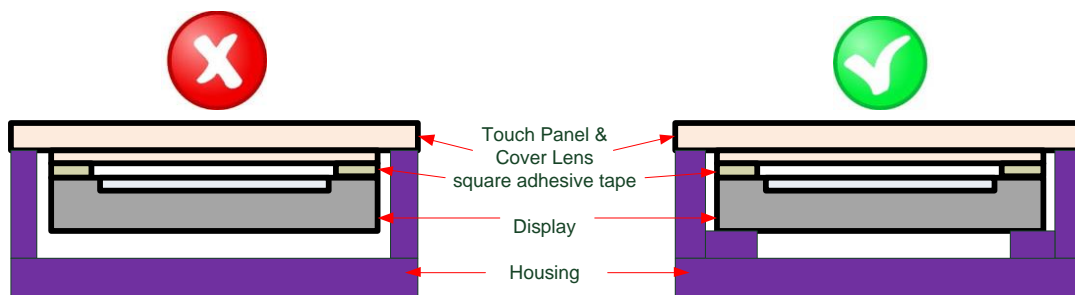

### **9.8 Static Electricity**

- (1) Protection film must remove very slowly from the surface of LCD module to prevent from electrostatic occurrence.
- (2) Because LCD modules use CMOS-IC on circuit board and TFT-LCD panel, it is very weak to electrostatic discharge. Please be careful with electrostatic discharge. Persons who handle the module should be grounded through adequate methods.

### **9.9 Strong Light Exposure**

The module shall not be exposed under strong light such as direct sunlight. Otherwise, display characteristics may be changed.

### **9.10 Disposal**

When disposing LCD module, obey the local environmental regulations.

### **9.11 Others**

Do not keep the LCD at the same display pattern continually. The residual image will happen and it will damage the LCD. Please use screen saver.

# 10.0 Outline Dimension

