



晶采光電科技股份有限公司
AMPIRE CO., LTD.

SPECIFICATIONS FOR LCD MODULE

CUSTOMER	
CUSTOMER PART NO.	
AMPIRE PART NO.	AM-320240NSTNQW-01H
APPROVED BY	
DATE	

- Approved For Specifications
- Approved For Specifications & Sample

AMPIRE CO., LTD.
Building D., 2F., No.88, Sec. 1, Sintai 5th Rd., Sijhih City,
Taipei County 221, Taiwan (R.O.C.)
台北縣汐止市新台五路一段 88 號 2 樓(東方科學園區 D 棟)
TEL:886-2-26967269 , FAX:886-2-86967196 or 26967270

APPROVED BY	CHECKED BY	ORGANIZED BY

RECORD OF REVISION

Revision Date	Page	Contents	Editor
2007/10/30	-	New Release	Sunglin
2008/3/4	5	Update the life time of LED-Backlight	Sunglin
2008/4/1	5.	Modify electrical characteristic of led back-light	Kasha
	20	Add guarantee declaration	Kasha

1 Features

5.7 inch Amorphous-TFT-LCD (Thin Film Transistor Liquid Crystal Display) module. This module is composed of a 5.7" TFT-LCD panel, a driver circuit and backlight unit.

- (1) Construction: 5.7" a-Si color TFT-LCD, White LED Backlight and PCB.
- (2) Resolution (pixel): 320(R.G.B) X240
- (3) Number of the Colors : 262K colors (R , G , B 6 bit digital each)
- (4) LCD type : Transmissive Color TFT LCD (normally White)
- (5) Interface: 33 pin
- (6) Power Supply Voltage: 3.3V single power input. Built-in power supply circuit.
- (7) Viewing Direction: 12 O'clock (The direction it's hard to be discolored)

2 Physical specifications

Item	Specifications	Unit
Display resolution(dot)	960 (W) x 240(H)	mm
Active area	115.2 (W) x 86.4 (H)	mm
Screen size	5.7(Diagonal)	mm
Pixel size	120 (W) x 360 (H)	um
Color configuration	R.G.B stripe	
Overall dimension	144.0(W)x104.6(H)x13.0(D)	mm
Weight	T.B.D	mg
Backlight unit	LED	

3 Electrical specification

3.1 Absolute max. ratings

3.1.1 Electrical Absolute max. ratings

Item	Symbol	Condition	Min.	Max.	Unit	Remark
Power voltage	VCC	VSS=0	-0.3	6.0	V	
Input voltege	V _{in}		-0.3	VCC+0.3	V	Note 1

Note1:Hsync, Vsync, ENAB, CK, R0~R5, G0~G5, B0~B5

3.1.2 Environmental Absolute max. ratings

Item	OPERATING		STORAGE		Remark
	MIN	MAX	MIN	MAX	
Temperature	-20	70	-30	80	Note2,3,4,5,7
Humidity	Note1		Note1		
Corrosive Gas	Not Acceptable		Not Acceptable		

Note1 : Ta ≤ 40°C : 85% RH max

Ta > 40°C : Absolute humidity must be lower than the humidity of 85%RH at 40°C

Note2 : For storage condition Ta at -30°C < 48h , at 80°C < 100h

For operating condition Ta at -20°C < 100h

Note3 : Background color changes slightly depending on ambient temperature. This phenomenon is reversible.

Note4 : The response time will be slower at low temperature.

Note5 : Only operation is guaranteed at operating temperature. Contrast , response time, another display quality are evaluated at +25°C

Note6 : When LCM is operated over 60°C ambient temperature, the I_L of the CCFL back-light should be adjusted to 3mA max

Note7 : This is panel surface temperature, not ambient temperature.

Note8 : When LCM be operated less than 0°C , the life time of the CCFL back-light will be reduced. The rise time of the CCFL ON will be longer when the ambient temperature below 0°C and confirm the characteristics of inverter is necessary.

3.2 Electrical characteristics

3.2.1 DC Electrical characteristic of the LCD

Typical operating conditions (VSS=0V)

Item	Symbol	Min.	Typ.	Max.	Unit	Remark
Power supply	VCC	3.0	3.3	3.6	V	
Input Voltage for logic	H Level	V_{IH}	0.7 VCC	-	VCC	Note 1
	L Level	V_{IL}	0	-	0.3 VCC	
Power Supply current	ICC		45	55	mA	Note 2

Note1: Hsync, Vsync, DEN, DCLK, R0~R5, G0~G5, B0~B5

Note2: $f_v = 60\text{Hz}$, $T_a = 25^\circ\text{C}$, Display pattern : All Black

3.2.2 Electrical characteristic of LED Back-light

Parameter	Symbol	Min.	Typ.	Max	Unit	Condition
LED voltage	V_{AK}	--	9.9	--	V	$I_{LED} = 480\text{mA}, T_a = 25^\circ\text{C}$
LED forward current	I_{LED}	--	480	500	mA	$T_a = 25^\circ\text{C}$
	I_{LED}	--	305	330	mA	$T_a = 60^\circ\text{C}$
Brightness Uniformity			75		%	$I_{LED} = 480\text{mA}, T_a = 25^\circ\text{C}$

- The constant current source is needed for white LED back-light driving. When LCM is operated over 60°C ambient temperature, the I_{LED} of the LED back-light should be adjusted to 240mA max

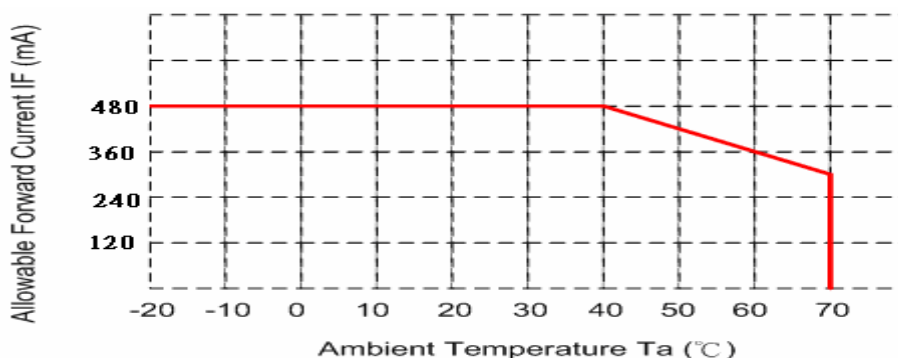

3.3 AC Timing characteristic of the LCD

a. Timing condition

Signal	Parameter	Symbol	Min.	Typ.	Max	Unit.	Remark	
DCLK	DCLK period	TOSC	-	156	-	ns		
	Frequency	FOSC	-	6.4	-	MHz		
	DCLK High plus width	TCH	-	78	-	ns		
	DCLK Low plus width	TCL	-	78	-	ns		
RGB DATA	Data setup time	TSU	12	-	-	ns		
	Data hold time	THD	12	-	-	ns		
Hsync	Hsync period	TH	-	408	-	TOSC		
	Hsync pulse width	THS	5	30	-	TOSC		
	Back-Porch	THB		38		TOSC		
	Front-Porch	THF		20		TOSC		
	Hsync rising time	TCr	-	-	700	ns		
	Hsync falling time	TCf	-	-	300	ns		
Vsync	Vsync period	NTSC	-	262.5	-	TH		
		PAL	-	312.5	-	TH		
	Vsync pulse width	TVS	1	3	5	TH		
	Back-Porch	NTSC	TVB		15		TH	
		PAL			23		TH	
	Display Period	TVD		240		TH		
	Front Porch	NTSC	TVF		4.5		TH	
		PAL			46.5		TH	
	Vsync rising time	TVr	-	-	700	ns		
	Vsync falling time	TVf	-	-	1.5	μ s		
	Vsync falling to Hsync rising time for odd field	THVO	1	-	-	TOSC		
Vsync falling to Hsync falling time for even field	THVE	1	-	-	TOSC			
ENAB	Vsync-DEN time	NTSC	TVSE	-	18	-	TH	
		PAL	TVSE	-	26	-	TH	
	Hsync-DEN time	THE	36	68	88	TOSC		
	DEN plus width	TEP	-	320	-	TOSC		

Note : If ENAB is fixed to low, the SYNC mode is used. Otherwise DE mode is used. When SYNC mode is used, 1st data start from 68th CK after Hsync falling

- Horizontal display timing

Note: Data is latched rising edge trigger of CLK.

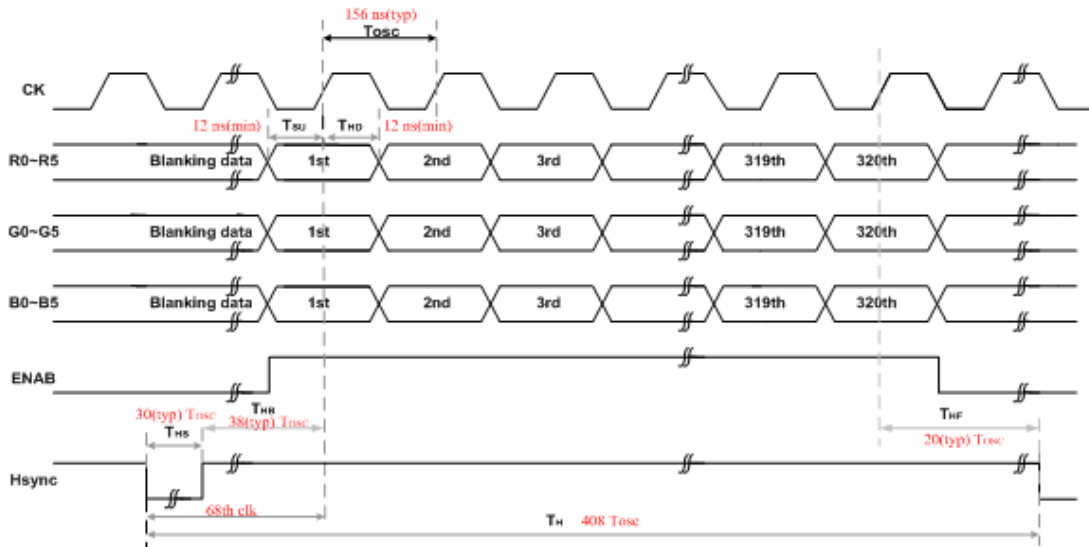

If ENAB is fixed to low, the SYNC mode is used. Otherwise DE mode is used.
When SYNC mode is used, 1st data start from 68th CK after Hsync falling

- Vertical display timing

- Vertical display timing

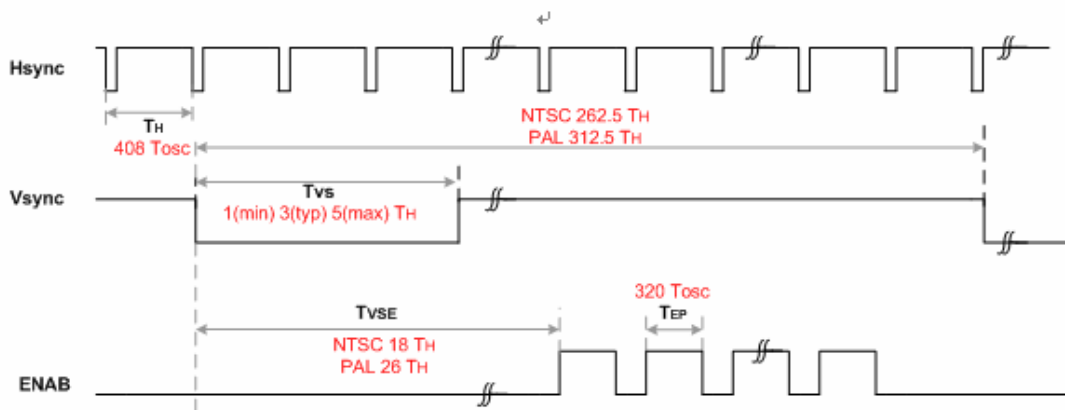

- Hsync and Vsync timing

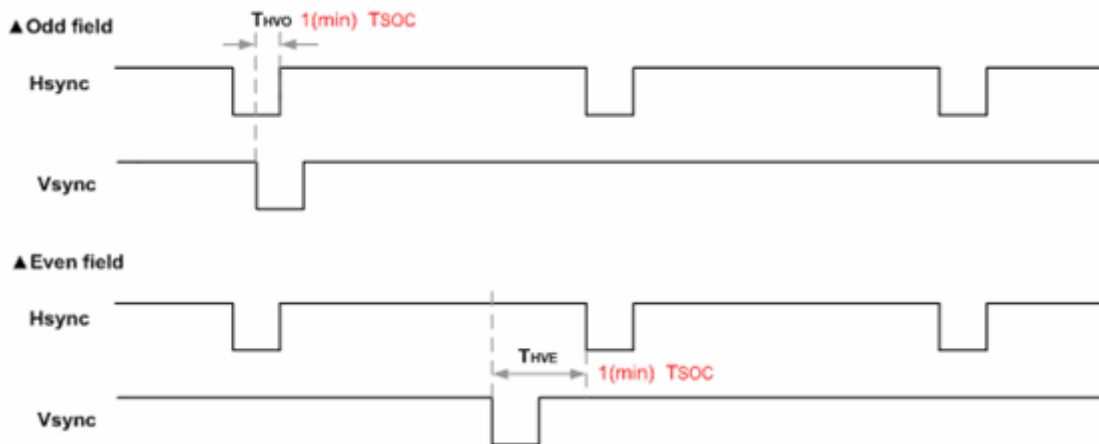

4 Optical specification

4.1 Optical characteristic of the LCD

Item		Symbol	Conditon	Min.	Typ.	Max.	Unit	Remark
Response Time	Rise	T_r	$\Theta = 0^\circ$	-	15	30	ms	Note 1,2,3,5
	Fall	T_f		-	35	50	ms	
Contrast ratio		CR	At optimized viewing angle		170	-		Note 1,2,4,5
Viewing Angle	Top		$CR \geq 10$	-	55	-	deg.	Note1,2,5,6
	Bottom			-	35	-		
	Left			-	70	-		
	Right			-	70	-		
Brightness		Y_L	$I_{LED}=480mA, 25^\circ C$	--	800	-	cd/m ²	Note 7
Red chromaticity	X_R	$\Theta = 0^\circ$ $\Theta = 0^\circ$		(0.592)	(0.622)	(0.652)		Note 7 For reference only. These data should be update according the prototype.
	Y_R			(0.336)	(0.366)	(0.396)		
Green chromaticity	X_G			(0.327)	(0.357)	(0.387)		
	Y_G			(0.530)	(0.560)	(0.590)		
Blue chromaticity	X_B			(0.111)	(0.141)	(0.171)		
	Y_B			(0.065)	(0.095)	(0.125)		
White chromaticity	X_W			(0.297)	(0.327)	(0.357)		
	Y_W			(0.318)	(0.348)	(0.378)		

() For reference only. These data should be update according the prototype.

Note 1: Ambient temperature=25°C, and lamp current $I_L=6$ mArms. To be measured in the dark room.

Note 2: To be measured on the center area of panel with a viewing cone of 1° by Topcon luminance meter BM-7, after 10 minutes operation.

Note 3. Definition of response time:

The output signals of photo detector are measured when the input signals are changed from "black" to "white" (falling time) and from "white" to "black" (rising time), respectively. The response time is defined as the time interval between the 10% and 90% of amplitudes. Refer to figure as below.

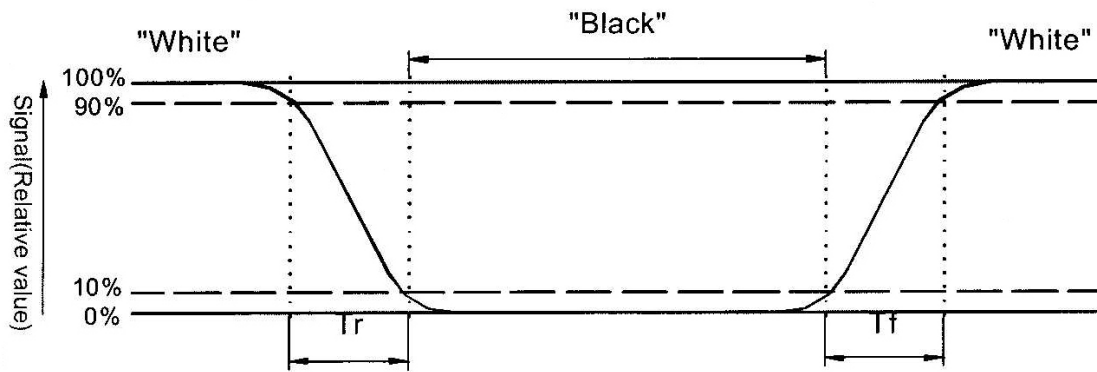

Note 4. Definition of contrast ratio:

Contrast ratio is calculated with the following formula.

$$\text{Contrast ratio(CR)} = \frac{\text{Photo detector output when LCD is at "White" state}}{\text{Photo detector Output when LCD is at "Black" state}}$$

Note 5: White $V_i = V_{i50} + 1.5V$

Black $V_i = V_{i50} + 2.0V$

“±” means that the analog input signal swings in phase with V_{COM} signal.

“-” means that the analog input signal swings out of phase with V_{COM} signal.

V_{i50} : The analog input voltage when transmission is 50%. The 100% Transmission is defined as the transmission of LCD panel when all the Input terminals of module are electrically opened.

Note 6. Definition of viewing angle, Refer to figure as below.

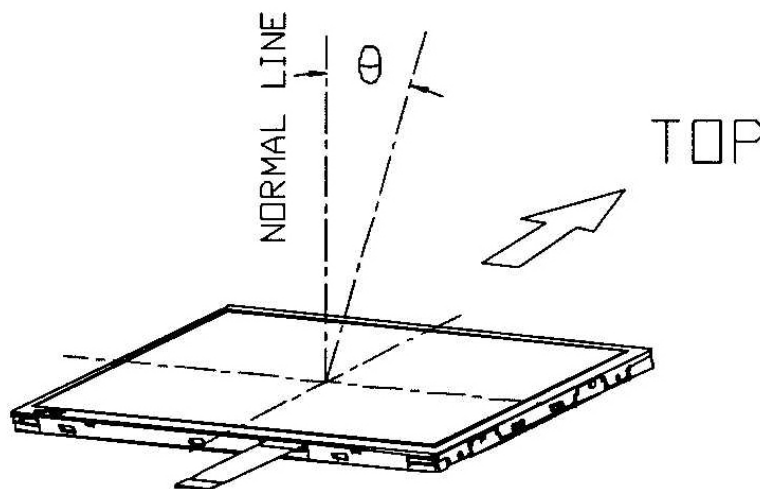

Note 7. Measured at the center area of the panel when all the input terminals of LCD panel are electrically opened.

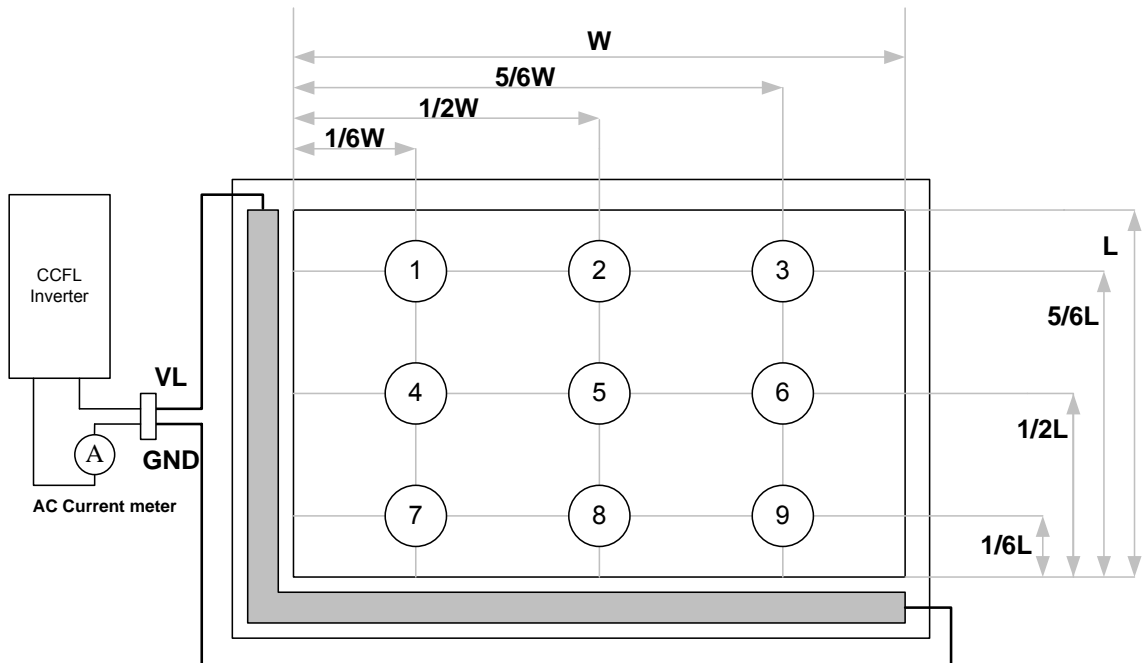
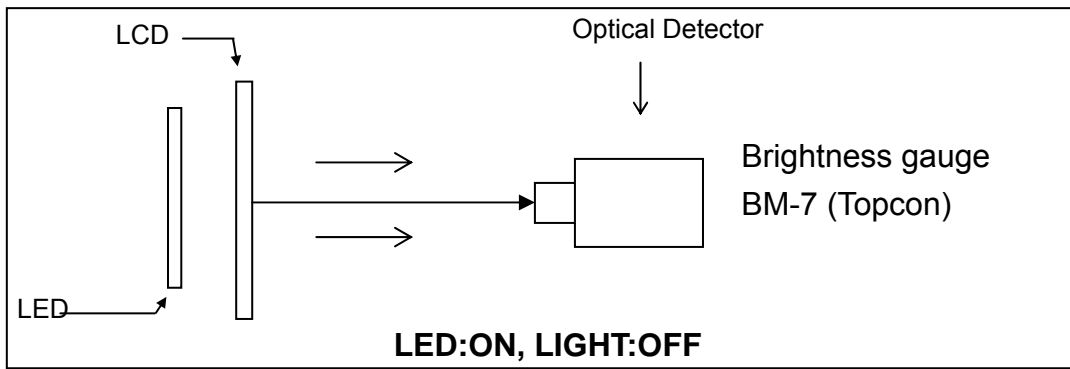
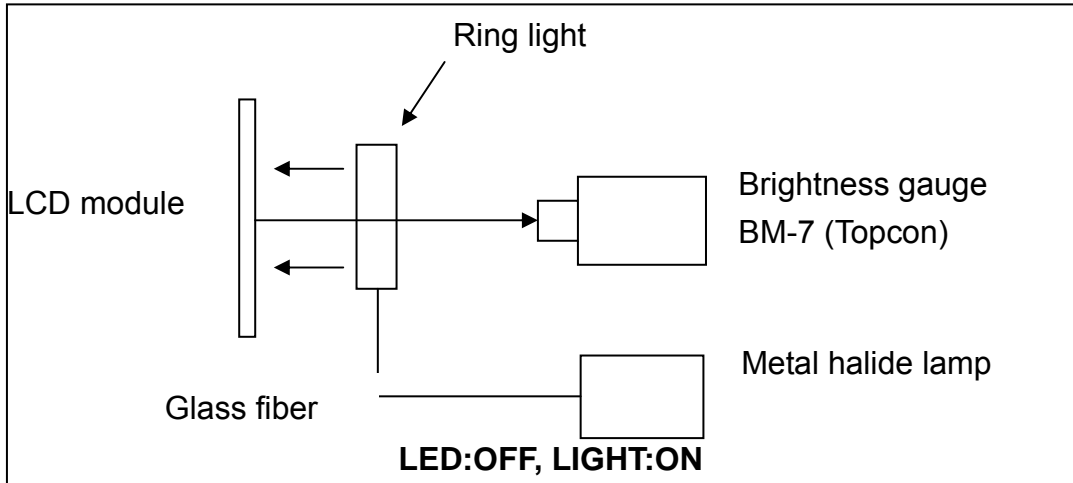

Note3: The Uniformity definition
 $(\text{Min Brightness} / \text{Max Brightness}) \times 100\%$

5 Interface specifications

5.1 Driving signals for the TFT panel

Pin no	Symbol	I/O	Description	Remark
1	GND		Gound	
2	CK		Clock signal. Latching data at the rising edge	
3	Hsync		Horizontal sync input in digital RGB mode	
4	Vsync		Vertical sync input in digital RGB mode	
5	GND	I	Gound	
6	R0	I	Red data	
7	R1	I		
8	R2	I		
9	R3	I		
10	R4	I		
11	R5	I		
12	GND	I	Gound	
13	G0	I	Green data	
14	G1	I		
15	G2	I		
16	G3	I		
17	G4	I		
18	G5	I		
19	GND	I	Gound	
20	B0	I	Blue data	
21	B1	I		
22	B2	I		
23	B3			
24	B4	I		
25	B5	I		
26	GND	I	Gound	
27	ENAB	I	Input data enable control	
28	VCC	I	+3.3V Power Supply	
29	VCC	I		
30	R/L	I	Right / Left Reveres Mode	
31	U/D	I	Up / Down Reveres Mode	
32	NC	I	Not use	
33	GND	I	Gound	

6 BLOCK DIAGRAM

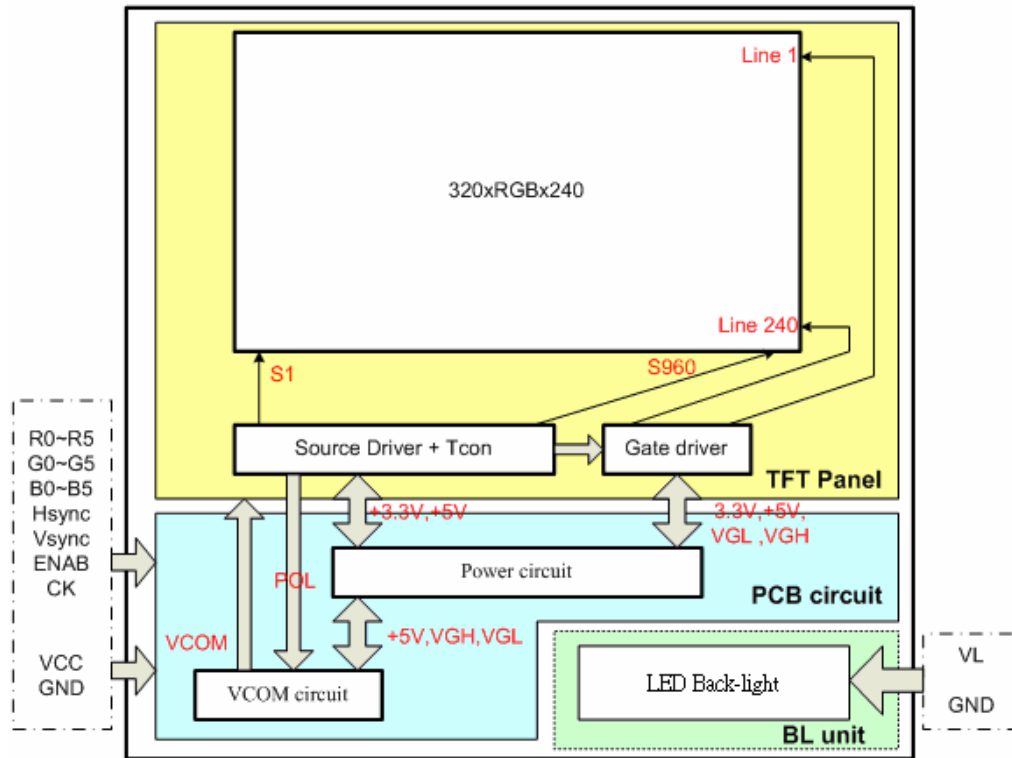

7 DISPLAYED COLOR AND INPUT DATA

	Color & Gray Scale	DATA SIGNAL																	
		R5	R4	R3	R2	R1	R0	G5	G4	G3	G2	G1	G0	B5	B4	B3	B2	B1	B0
Basic Color	Black	0	0	0	0	0	0	0	0	0	0	0	0	0	0	0	0	0	0
	Red(0)	1	1	1	1	1	1	0	0	0	0	0	0	0	0	0	0	0	0
	Green(0)	0	0	0	0	0	0	0	1	1	1	1	1	0	0	0	0	0	0
	Blue(0)	0	0	0	0	0	0	0	0	0	0	0	0	1	1	1	1	1	1
	Cyan	0	0	0	0	0	0	1	1	1	1	1	1	1	1	1	1	1	1
	Magenta	1	1	1	1	1	1	0	0	0	0	0	0	1	1	1	1	1	1
	Yellow	1	1	1	1	1	1	1	1	1	1	1	1	0	0	0	0	0	0
White	1	1	1	1	1	1	1	1	1	1	1	1	1	1	1	1	1	1	
Red	Black	0	0	0	0	0	0	0	0	0	0	0	0	0	0	0	0	0	0
	Red(62)	0	0	0	0	0	1	0	0	0	0	0	0	0	0	0	0	0	0
	Red(61)	0	0	0	0	0	1	0	0	0	0	0	0	0	0	0	0	0	0
	:	:	:	:	:	:	:	:	:	:	:	:	:	:	:	:	:	:	:
	Red(31)	0	1	1	1	1	1	0	0	0	0	0	0	0	0	0	0	0	0
	:	:	:	:	:	:	:	:	:	:	:	:	:	:	:	:	:	:	:
Red(1)	1	1	1	1	1	0	0	0	0	0	0	0	0	0	0	0	0	0	
Red(0)	1	1	1	1	1	1	0	0	0	0	0	0	0	0	0	0	0	0	
Green	Black	0	0	0	0	0	0	0	0	0	0	0	0	0	0	0	0	0	0
	Green(62)	0	0	0	0	0	0	0	0	0	0	0	1	0	0	0	0	0	0
	Green(61)	0	0	0	0	0	0	0	0	0	0	1	0	0	0	0	0	0	0
	:	:	:	:	:	:	:	:	:	:	:	:	:	:	:	:	:	:	:
	Green(31)	0	0	0	0	0	0	0	1	1	1	1	0	0	0	0	0	0	0
	:	:	:	:	:	:	:	:	:	:	:	:	:	:	:	:	:	:	:
Green(1)	0	0	0	0	0	0	1	1	1	1	1	0	0	0	0	0	0	0	
Green(0)	0	0	0	0	0	0	1	1	1	1	1	1	0	0	0	0	0	0	
Blue	Black	0	0	0	0	0	0	0	0	0	0	0	0	0	0	0	0	0	0
	Blue(62)	0	0	0	0	0	0	0	0	0	0	0	0	0	0	0	0	0	1
	Blue(61)	0	0	0	0	0	0	0	0	0	0	0	0	0	0	0	0	0	1
	:	:	:	:	:	:	:	:	:	:	:	:	:	:	:	:	:	:	:
	Blue(31)	0	0	0	0	0	0	0	0	0	0	0	0	0	1	1	1	1	1
	:	:	:	:	:	:	:	:	:	:	:	:	:	:	:	:	:	:	:
Blue(1)	0	0	0	0	0	0	0	0	0	0	0	0	1	1	1	1	1	0	
Blue(0)	0	0	0	0	0	0	0	0	0	0	0	0	1	1	1	1	1	1	

8 QUALITY AND RELIABILITY

8.1 TEST CONDITIONS

Tests should be conducted under the following conditions :

Ambient temperature : $25 \pm 5^{\circ}\text{C}$

Humidity : $60 \pm 25\% \text{ RH}$.

8.2 SAMPLING PLAN

Sampling method shall be in accordance with MIL-STD-105E , level II, normal single sampling plan .

8.3 ACCEPTABLE QUALITY LEVEL

A major defect is defined as one that could cause failure to or materially reduce the usability of the unit for its intended purpose. A minor defect is one that does not materially reduce the usability of the unit for its intended purpose or is an infringement from established standards and has no significant bearing on its effective use or operation.

8.4 APPEARANCE

An appearance test should be conducted by human sight at approximately 30 cm distance from the LCD module under fluorescent light. The inspection area of LCD panel shall be within the range of following limits.

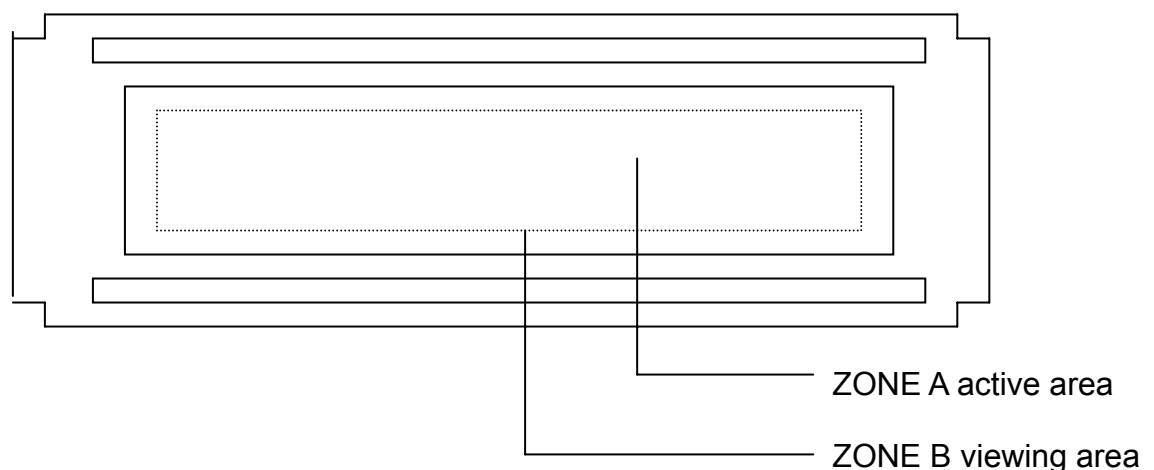

8.5 INSPECTION QUALITY CRITERIA

No.	Item	Criterion for defects	Defect type															
1	Non display	No non display is allowed	Major															
2	Irregular operation	No irregular operation is allowed	Major															
3	Short	No short are allowed	Major															
4	Open	Any segments or common patterns that don't activate are rejectable.	Major															
5	Mura/Spot	ND 3% filter visible is reject. ND 3% filter visible is reject	Major															
6	Line defect	<table border="1" style="width: 100%; border-collapse: collapse;"> <thead> <tr> <th style="text-align: center;">Inspected Items</th> <th style="text-align: center;">Criteria</th> </tr> </thead> <tbody> <tr> <td style="text-align: center;">Weak line</td> <td style="text-align: center;">ND 6%see,Reject</td> </tr> <tr> <td style="text-align: center;">Clear Line</td> <td style="text-align: center;">Reject</td> </tr> <tr> <td style="text-align: center;">Broken Line</td> <td style="text-align: center;">Reject</td> </tr> <tr> <td style="text-align: center;">One point one weak line / Sipder missing line</td> <td style="text-align: center;">Reject</td> </tr> </tbody> </table>	Inspected Items	Criteria	Weak line	ND 6%see,Reject	Clear Line	Reject	Broken Line	Reject	One point one weak line / Sipder missing line	Reject	Major					
Inspected Items	Criteria																	
Weak line	ND 6%see,Reject																	
Clear Line	Reject																	
Broken Line	Reject																	
One point one weak line / Sipder missing line	Reject																	
7	Black/White spot (II)	<table border="1" style="width: 100%; border-collapse: collapse;"> <thead> <tr> <th style="text-align: center;">Size D (mm)</th> <th style="text-align: center;">Acceptable number</th> </tr> </thead> <tbody> <tr> <td style="text-align: center;">$D \leq 0.30$</td> <td style="text-align: center;">Ignore</td> </tr> <tr> <td style="text-align: center;">$0.30 < D \leq 0.50$</td> <td style="text-align: center;">5</td> </tr> <tr> <td style="text-align: center;">$0.50 < D \leq 1.20$</td> <td style="text-align: center;">2</td> </tr> <tr> <td style="text-align: center;">$1.20 < D$</td> <td style="text-align: center;">0</td> </tr> </tbody> </table>	Size D (mm)	Acceptable number	$D \leq 0.30$	Ignore	$0.30 < D \leq 0.50$	5	$0.50 < D \leq 1.20$	2	$1.20 < D$	0	Minor					
Size D (mm)	Acceptable number																	
$D \leq 0.30$	Ignore																	
$0.30 < D \leq 0.50$	5																	
$0.50 < D \leq 1.20$	2																	
$1.20 < D$	0																	
8	Black/White line (II)	<table border="1" style="width: 100%; border-collapse: collapse;"> <thead> <tr> <th style="text-align: center;">Length (mm)</th> <th style="text-align: center;">Width (mm)</th> <th style="text-align: center;">Acceptable number</th> </tr> </thead> <tbody> <tr> <td style="text-align: center;">$20 < L$</td> <td style="text-align: center;">$0.05 < W \leq 0.07$</td> <td style="text-align: center;">5</td> </tr> <tr> <td style="text-align: center;">$10 < L \leq 20$</td> <td style="text-align: center;">$0.07 < W \leq 0.09$</td> <td style="text-align: center;">3</td> </tr> <tr> <td style="text-align: center;">$5.0 < L \leq 10$</td> <td style="text-align: center;">$0.09 < W \leq 0.10$</td> <td style="text-align: center;">2</td> </tr> <tr> <td style="text-align: center;">$L < 5.0$</td> <td style="text-align: center;">$0.10 < W \leq 0.15$</td> <td style="text-align: center;">1</td> </tr> </tbody> </table>	Length (mm)	Width (mm)	Acceptable number	$20 < L$	$0.05 < W \leq 0.07$	5	$10 < L \leq 20$	$0.07 < W \leq 0.09$	3	$5.0 < L \leq 10$	$0.09 < W \leq 0.10$	2	$L < 5.0$	$0.10 < W \leq 0.15$	1	Minor
Length (mm)	Width (mm)	Acceptable number																
$20 < L$	$0.05 < W \leq 0.07$	5																
$10 < L \leq 20$	$0.07 < W \leq 0.09$	3																
$5.0 < L \leq 10$	$0.09 < W \leq 0.10$	2																
$L < 5.0$	$0.10 < W \leq 0.15$	1																
9	Back Light	1. No Lighting is rejectable 2. Flickering and abnormal lighting are rejectable	Major															
10	Display pattern	<div style="text-align: center;"> <p style="text-align: center;">Unit:mm</p> <table border="1" style="width: 100%; border-collapse: collapse;"> <tbody> <tr> <td style="text-align: center;">$\frac{A+B}{2} \leq 0.30$</td> <td style="text-align: center;">$0 < C$</td> <td style="text-align: center;">$\frac{D+E}{2} \leq 0.25$</td> <td style="text-align: center;">$\frac{F+G}{2} \leq 0.25$</td> </tr> </tbody> </table> <p style="text-align: center;">Note: 1. Acceptable up to 3 damages 2. NG if there're to two or more pinholes per dot</p> </div>	$\frac{A+B}{2} \leq 0.30$	$0 < C$	$\frac{D+E}{2} \leq 0.25$	$\frac{F+G}{2} \leq 0.25$	Minor											
$\frac{A+B}{2} \leq 0.30$	$0 < C$	$\frac{D+E}{2} \leq 0.25$	$\frac{F+G}{2} \leq 0.25$															

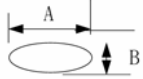
11	Foreign Material Defect.	11.1 Bright defect use ND10% to inspect, if they will be seen, then using			Minor																					
			SPEC	Quantity		Note.																				
				A area			B area	total																		
		Bright line defect	$L \leq 3.0\text{mm}$	Ignore		$W \leq 0.05\text{mm}$																				
			$0.3\text{mm} < L \leq 3.0\text{mm}$	2			4	6																		
			$L > 0.6\text{mm}$	Reject																						
		Bright Spot defect	$D \leq 0.15\text{mm}$	Ignore		$W > 0.05\text{mm}$																				
			$0.15\text{mm} < D \leq 0.3\text{mm}$	$N \leq 3$																						
			$D > 0.3\text{mm}$	Reject																						
		Dark line defect	$L \leq 2.0\text{mm}$	Ignore		$W \leq 0.05\text{mm}$																				
			$2\text{mm} < L \leq 3.0\text{mm}$	$N \leq 4$																						
$L > 3\text{mm}$	Reject																									
Dark Spot defect	$D \leq 0.15\text{mm}$	Ignore		$W > 0.05\text{mm}$																						
	$0.15\text{mm} < D \leq 0.5\text{mm}$	$N \leq 5$																								
	$L > 0.5\text{mm}$	Reject																								
11.1 Bright defect use ND 10% to inspect, if they will be seen, then using point defect or line defect to judge again.																										
11.2 Any two points distance $\geq 5\text{mm}$																										
12	Scratch on Polarizer 	<table border="1"> <thead> <tr> <th>Width (mm)</th> <th>Length (mm)</th> <th>Acceptable number</th> </tr> </thead> <tbody> <tr> <td>$W \leq 0.03$</td> <td>Ignore</td> <td>Ignore</td> </tr> <tr> <td>$0.03 < W \leq 0.05$</td> <td>$L \leq 2.0$</td> <td>Ignore</td> </tr> <tr> <td></td> <td>$L > 2.0$</td> <td>1</td> </tr> <tr> <td>$0.05 < W \leq 0.08$</td> <td>$L > 1.0$</td> <td>1</td> </tr> <tr> <td></td> <td>$L \leq 1.0$</td> <td>Ignore</td> </tr> <tr> <td>$0.08 < W$</td> <td>Note (1)</td> <td>Note(1)</td> </tr> </tbody> </table>			Width (mm)	Length (mm)	Acceptable number	$W \leq 0.03$	Ignore	Ignore	$0.03 < W \leq 0.05$	$L \leq 2.0$	Ignore		$L > 2.0$	1	$0.05 < W \leq 0.08$	$L > 1.0$	1		$L \leq 1.0$	Ignore	$0.08 < W$	Note (1)	Note(1)	Minor
		Width (mm)	Length (mm)	Acceptable number																						
$W \leq 0.03$	Ignore	Ignore																								
$0.03 < W \leq 0.05$	$L \leq 2.0$	Ignore																								
	$L > 2.0$	1																								
$0.05 < W \leq 0.08$	$L > 1.0$	1																								
	$L \leq 1.0$	Ignore																								
$0.08 < W$	Note (1)	Note(1)																								
Note(1) Regard as a blemish Note(2) Distance LCM 30cm, base on visible scratch.																										
13	Bubble in polarizer	Distance LCM 30cm, base on visible.			Minor																					
		<table border="1"> <thead> <tr> <th>Size D (mm)</th> <th>Acceptable number</th> </tr> </thead> <tbody> <tr> <td>$D \leq 0.20$</td> <td>Ignore</td> </tr> <tr> <td>$0.20 < D \leq 0.50$</td> <td>3</td> </tr> <tr> <td>$0.50 < D \leq 0.80$</td> <td>2</td> </tr> <tr> <td>$0.80 < D$</td> <td>0</td> </tr> </tbody> </table>				Size D (mm)	Acceptable number	$D \leq 0.20$	Ignore	$0.20 < D \leq 0.50$	3	$0.50 < D \leq 0.80$	2	$0.80 < D$	0											
Size D (mm)	Acceptable number																									
$D \leq 0.20$	Ignore																									
$0.20 < D \leq 0.50$	3																									
$0.50 < D \leq 0.80$	2																									
$0.80 < D$	0																									
14	Stains on LCD panel surface	Stains that cannot be removed even when wiped lightly with a soft cloth or similar cleaning too are rejectable. Distance LCM 30cm, base on visible.			Minor																					
15	Rust in Bezel	Rust which is visible in the bezel is rejectable.			Minor																					
16	Defect of land surface contact (poor soldering)	Evident crevices which is visible are rejectable.			Minor																					
17	Parts mounting	1. Failure to mount parts 2. Parts not in the specifications are mounted 3. Polarity, for example, is reversed			Major Major Major																					
18	Parts alignment	1. LSI, IC lead width is more than 50% beyond pad outline. 2. Chip component is off center and more than 50% of the leads is off the pad outline.			Minor Minor																					

19	Conductive foreign matter (Solder ball, Solder chips)	1. $0.45 < \varphi$, $N \geq 1$ 2. $0.30 < \varphi \leq 0.45$, $N \geq 1$ φ : Average diameter of solder ball (unit: mm) 3. $0.50 < L$, $N \geq 1$ L: Average length of solder chip (unit: mm)	Major Minor Minor								
20	Faulty PCB correction	1. Due to PCB copper foil pattern burnout, the pattern is connected, using a jumper wire for repair; 2 or more places are corrected per PCB. 2. Short circuited part is cut, and no resist coating has been performed.	Minor Minor								
21	Defect Dot	The TFT panel may have bright dot or Dark dot. The acceptable number defection: <table border="1" style="margin-left: 20px;"> <tr> <td>Bright dot</td> <td>Dark dot</td> <td>Total dot</td> <td>Distance between Dark-- dark</td> </tr> <tr> <td>3</td> <td>5</td> <td>7</td> <td>$L \geq 5$ mm</td> </tr> </table>	Bright dot	Dark dot	Total dot	Distance between Dark-- dark	3	5	7	$L \geq 5$ mm	Minor
Bright dot	Dark dot	Total dot	Distance between Dark-- dark								
3	5	7	$L \geq 5$ mm								

8.6 RELIABILITY

Test Item	Test Conditions	Note
High Temperature Operation	$70 \pm 3^\circ\text{C}$, t=96 hrs	
Low Temperature Operation	$-20 \pm 3^\circ\text{C}$, t=96 hrs	
High Temperature Storage	$80 \pm 3^\circ\text{C}$, t=96 hrs	1,2
Low Temperature Storage	$-30 \pm 3^\circ\text{C}$, t=96 hrs	1,2
Thermal Shock Test	$-20^\circ\text{C} \sim 25^\circ\text{C} \sim 70^\circ\text{C}$ 30 min. 5 min. 30 min. (1 cycle) Total 5 cycle	1,2
Humidity Test	40°C , Humidity 90%, 96 hrs	1,2
Vibration Test (Packing)	Sweep frequency : 10 ~ 55 ~ 10 Hz/1min Amplitude : 0.75mm Test direction : X.Y.Z/3 axis Duration : 30min/each axis	2

Note 1 : Condensation of water is not permitted on the module.

Note 2 : The module should be inspected after 1 hour storage in normal conditions ($15\text{-}35^\circ\text{C}$, 45-65%RH).

Definitions of life end point :

- Current drain should be smaller than the specific value.
- Function of the module should be maintained.
- Appearance and display quality should not have degraded noticeably.
- Contrast ratio should be greater than 50% of the initial value.

USE PRECAUTIONS

9 HANDLING PRECAUTIONS

- (1) An LCD module is a fragile item and should not be subjected to strong mechanical shocks.
- (2) Avoid applying pressure to the module surface. This will distort the glass and cause a change in colour.
- (3) Under no circumstances should the position of the bezel tabs or their shape be modified.
- (4) Do not modify the display PCB in either shape or positioning of components.
- (5) Do not modify or move location of the zebra or heat seal connectors.
- (6) The device should only be soldered to during interfacing. Modification to other areas of the board should not be carried out.
- (7) In the event of LCD breakage and resultant leakage of fluid do not inhale, ingest or make contact with the skin. If contact is made rinse immediately.
- (8) When cleaning the module use a soft damp cloth with a mild solvent, such as Isopropyl or Ethyl alcohol. The use of water, ketone or aromatic is not permitted.
- (9) Prior to initial power up input signals should not be applied.
- (10) Protect the module against static electricity and observe appropriate anti-static precautions.

9.1 Installing precautions

- 1) The PCB has many ICs that may be damaged easily by static electricity. To prevent breaking by static electricity from the human body and clothing, earth the human body properly using the high resistance and discharge static electricity during the operation. In this case, however, the resistance value should be approx. $1M\Omega$ and the resistance should be placed near the human body rather than the ground surface. When the indoor space is dry, static electricity may occur easily so be careful. We recommend the indoor space should be kept with humidity of 60% or more. When a soldering iron or other similar tool is used for assembly, be sure to earth it.
- 2) When installing the module and ICs, do not bend or twist them. Failure to do so may crack LC element and cause circuit failure.
- 3) To protect LC element, especially polarizing plate, use a transparent protective plate (e.g., acrylic plate, glass etc) for the product case.
- 4) Do not use an adhesive like a both-side adhesive tape to make LCD surface

(polarizing plate) and product case stick together. Failure to do so may cause the polarizing plate to peel off.

9.2 Storage precautions

- 1) Avoid a high temperature and humidity area. Keep the temperature between 0°C and 35°C and also the humidity under 60%.
- 2) Choose the dark spaces where the product is not exposed to direct sunlight or fluorescent light.
- 3) Store the products as they are put in the boxes provided from us or in the same conditions as we recommend.

9.3 Operating precautions

- 1) Do not boost the applied drive voltage abnormally. Failure to do so may break ICs. When applying power voltage, check the electrical features beforehand and be careful. Always turn off the power to the LC module controller before removing or inserting the LC module input connector. If the input connector is removed or inserted while the power is turned on, the LC module internal circuit may break.
- 2) The display response may be late if the operating temperature is under the normal standard, and the display may be out of order if it is above the normal standard. But this is not a failure; this will be restored if it is within the normal standard.
- 3) The LCD contrast varies depending on the visual angle, ambient temperature, power voltage etc. Obtain the optimum contrast by adjusting the LC drive voltage.
- 4) When carrying out the test, do not take the module out of the low-temperature space suddenly. Failure to do so will cause the module condensing, leading to malfunctions.
- 5) Make certain that each signal noise level is within the standard (L level: 0.2V_{dd} or less and H level: 0.8V_{dd} or more) even if the module has functioned properly. If it is beyond the standard, the module may often malfunction. In addition, always connect the module when making noise level measurements.
- 6) The CMOS ICs are incorporated in the module and the pull-up and pull-down function is not adopted for the input so avoid putting the input signal open while the power is ON.
- 7) The characteristic of the semiconductor element changes when it is exposed to light emissions, therefore ICs on the LCD may malfunction if they receive light emissions. To prevent these malfunctions, design and assemble ICs so

that they are shielded from light emissions.

- 8) Crosstalk occurs because of characteristics of the LCD. In general, crosstalk occurs when the regularized display is maintained. Also, crosstalk is affected by the LC drive voltage. Design the contents of the display, considering crosstalk.

9.4 Other

- 1) Do not disassemble or take the LC module into pieces. The LC modules once disassembled or taken into pieces are not the guarantee articles.
- 2) The residual image may exist if the same display pattern is shown for hours. This residual image, however, disappears when another display pattern is shown or the drive is interrupted and left for a while. But this is not a problem on reliability.
- 3) AMIPRE will provide one year warranty for all products and three months warrantee for all repairing products.

10 OUTLINE DIMENSION

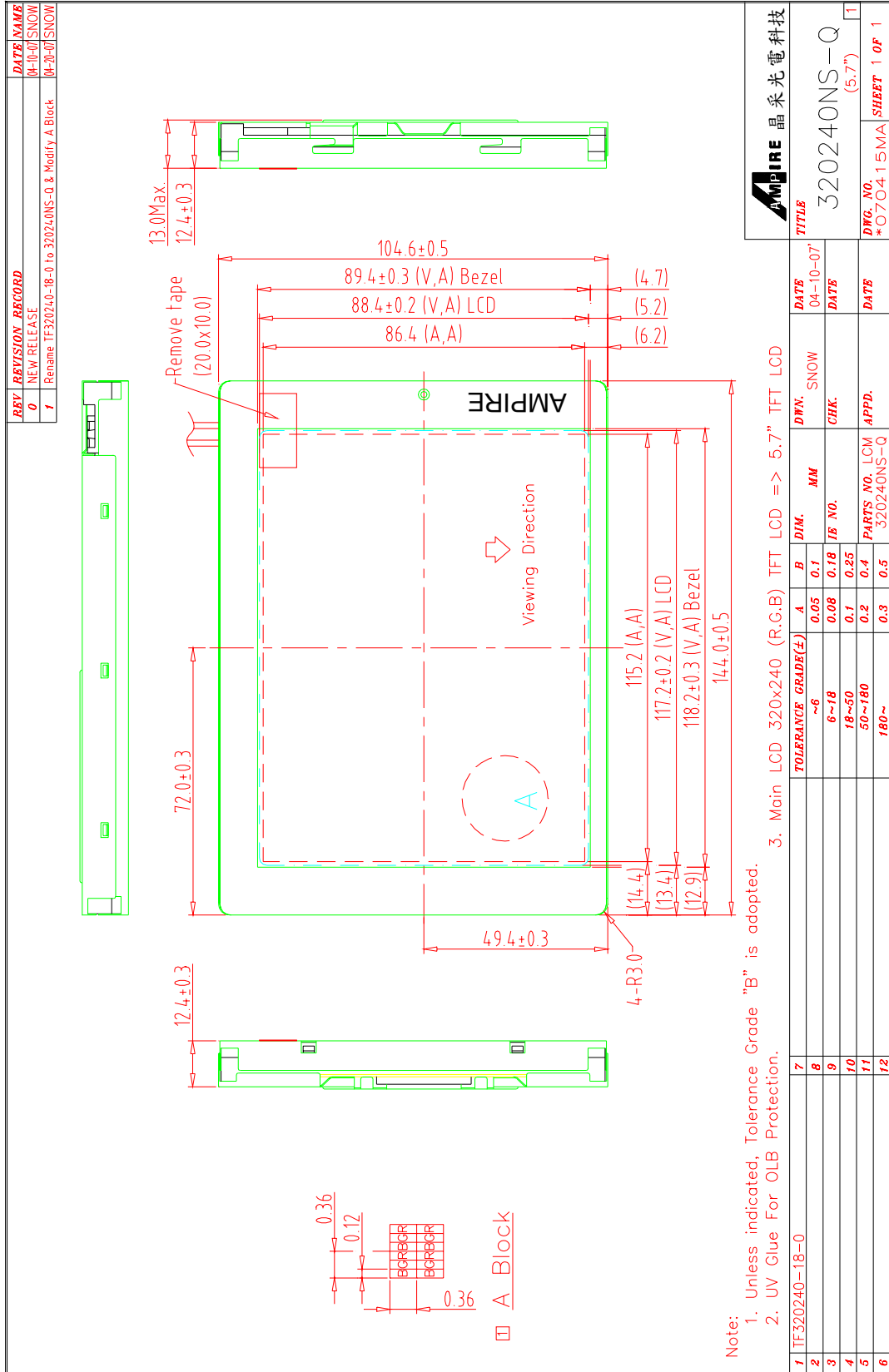

REV	REVISION RECORD	DATE	NAME
0	NEW RELEASE	04-10-07	SNOW
1	Rename TF320240-18-0 To 320240NS-Q & Modify A Block	04-20-07	SNOW

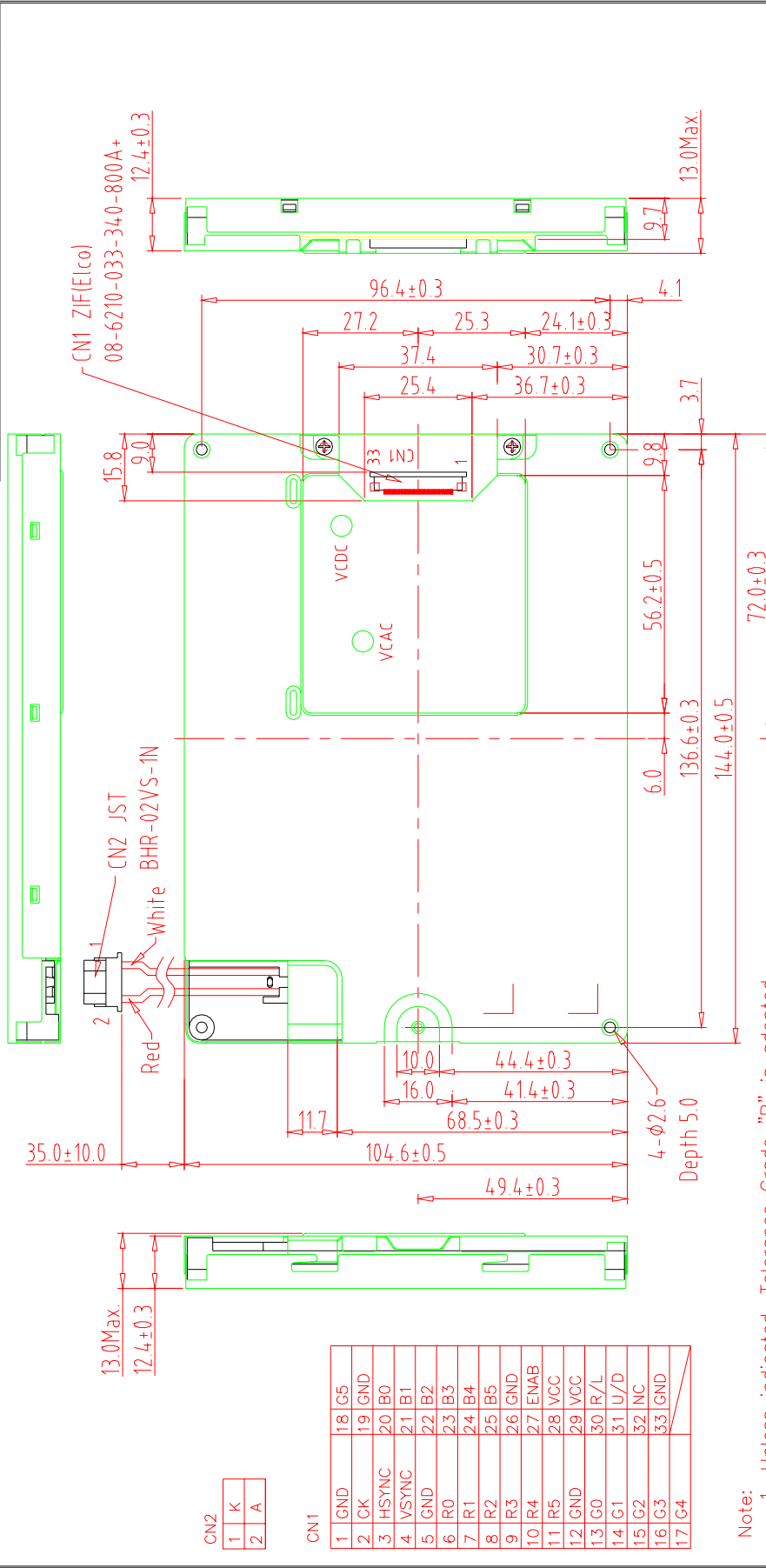

CN2	
1	K
2	A

CN1	
1	GND
2	GND
3	HSYNC
4	VSYNC
5	GND
6	R0
7	R1
8	R2
9	R3
10	R4
11	R5
12	GND
13	G0
14	G1
15	G2
16	G3
17	G4
18	G5
19	GND
20	B0
21	B1
22	B2
23	B3
24	B4
25	B5
26	GND
27	ENAB
28	VCC
29	VCC
30	R/L
31	U/D
32	NC
33	GND

- Note:
1. Unless indicated, Tolerance Grade "B" is adopted.
 2. UV Glue For OLB Protection.
 3. Main LCD 320x240 (R.G.B) TFT LCD => 5.7" TFT LCD

TOLERANCE GRADE(±)		A	B	DIM.	MM	DWN.	DATE	TITLE
7	~6	0.05	0.1			SNOW	04-10-07	AMPIRE 晶采光電科技 320240NS-Q (5.7") DWG. NO. *070416MA SHEET 1 OF 1
8	6~18	0.08	0.18	IE NO.		CHK.		
9	18~50	0.1	0.25	PARTS NO. LCM-1		APPD.		
10	50~180	0.2	0.4	320240NS-Q				
11	180~	0.3	0.5					
12								