



晶采光電科技股份有限公司
AMPIRE CO., LTD.

SPECIFICATIONS FOR LCD MODULE

CUSTOMER	
CUSTOMER PART NO.	
AMPIRE PART NO.	AM-320240N6TMQW-T50H-A
APPROVED BY	
DATE	

- Approved For Specifications
 Approved For Specifications & Sample

AMPIRE CO., LTD.
Building D., 2F., No.88, Sec. 1, Sintai 5th Rd., Sijhih City,
Taipei County 221, Taiwan (R.O.C.)
台北縣汐止市新台五路一段 88 號 2 樓(東方科學園區 D 棟)
TEL:886-2-26967269 , FAX:886-2-86967196 or 26967270

APPROVED BY	CHECKED BY	ORGANIZED BY

RECORD OF REVISION

Revision Date	Page	Contents	Editor
2009/09/07	-	New Release	Emil

1 Features

5.7 inch Amorphous-TFT-LCD (Thin Film Transistor Liquid Crystal Display) module. This module is composed of a 5.7" TFT-LCD panel, Touch Panel, a driver circuit and backlight unit.

- (1) Construction: 5.7" a-Si color TFT-LCD, White LED Backlight and PCB.
- (2) Resolution (pixel): 320(R.G.B) X240
- (3) Number of the Colors : 262K colors (R , G , B 6 bit digital each)
- (4) LCD type : Transmissive Color TFT LCD (normally White)
- (5) Interface: 40 pin
- (6) Power Supply Voltage: 3.3V single power input. Built-in power supply circuit.
- (7) Viewing Direction: 6 O'clock (The direction it's hard to be discolored)

2 Physical specifications

Item	Specifications	Unit	
Display resolution(dot)	960 (W) x 240(H)	mm	
Active area	115.2 (W) x 86.4 (H)	mm	
Screen size	5.7(Diagonal)	mm	
Pixel size	120 (W) x 360 (H)	um	
Color configuration	R.G.B stripe		
Overall dimension	126.0(W)x101.8(H)x9.7(D)	mm	
Weight	T.B.D	mg	
Backlight unit	LED		

3 Electrical specification

3.1 Absolute max. ratings

3.1.1 Electrical Absolute max. ratings

Item	Symbol	Condition	Min.	Max.	Unit	Remark
Power voltage	VDD	VSS=0	-0.3	6.0	V	
Input voltege	V _{in}		-0.3	VDD+0.3	V	Note 1

Note1:Hsync, Vsync, DEN, DCLK, R0~R5, G0~G5, B0~B5

3.1.2 Environmental Absolute max. ratings

Item	OPERATING		STORAGE		Remark
	MIN	MAX	MIN	MAX	
Temperature	-20	70	-30	80	Note2,3,4,5,6,7
Humidity	Note1		Note1		
Corrosive Gas	Not Acceptable		Not Acceptable		

Note1 : Ta ≤ 40°C : 85% RH max

Ta > 40°C : Absolute humidity must be lower than the humidity of 85%RH at 40°C

Note2 : For storage condition Ta at -30°C < 48h , at 80°C < 100h

For operating condition Ta at -20°C < 100h

Note3 : Background color changes slightly depending on ambient temperature. This phenomenon is reversible.

Note4 : The response time will be slower at low temperature.

Note5 : Only operation is guaranteed at operating temperature. Contrast , response time, another display quality are evaluated at +25°C

Note6 : When LCM is operated over 60°C ambient temperature, the I_{LED} of the LED back-light should be adjusted to 105mA max

Note7 : This is panel surface temperature, not ambient temperature.

3.1.3 LED back-light Unit Absolute max. ratings

Item	Symbol	Ratings	Unit	Remark
Peak forward Current	IF	350	mA	
Reverse Voltage	VR	30	V	
Power Dissipation	Po	1.2	W	

3.2 Electrical characteristics

3.2.1 DC Electrical characteristic of the LCD

Typical operating conditions (VSS=0V)

Item	Symbol	Min.	Typ.	Max.	Unit	Remark	
Power supply	VDD	3.0	3.3	3.6	V		
Input Voltage for logic	H Level	V_{IH}	0.7 VDD	-	VDD	V	Note 1
	L Level	V_{IL}	0	-	0.3 VDD	V	
Power Supply current	IDD		45	55	mA	Note 2	

Note1: Hsync, Vsync, DEN, DCLK, R0~R5, G0~G5, B0~B5

Note2: $f_v = 60\text{Hz}$, $T_a = 25^\circ\text{C}$, Display pattern : All Black

3.2.2 Electrical characteristic of LED Back-light

Parameter	Symbol	Min.	Typ.	Max.	Unit	Condition
LED voltage	V_{AK}	--	10.5	12	V	$I_{LED} = 126\text{mA}, T_a = 25^\circ\text{C}$
LED forward current	I_{LED}	--	126	140	mA	$T_a = 25^\circ\text{C}$
	I_{LED}	--	84	105	mA	$T_a = 60^\circ\text{C}$
Lamp life time		10,000	-	-	Hr	$I_{LED} = 126\text{mA}, T_a = 25^\circ\text{C}$

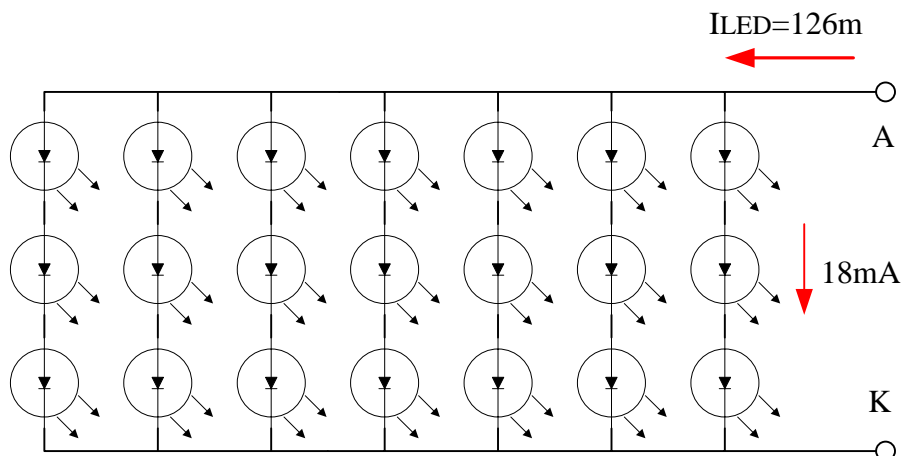

- The constant current source is needed for white LED back-light driving.
- When LCM is operated over 60°C ambient temperature, the I_{LED} of the LED back-light should be adjusted to 105mA max

3.3 AC Timing characteristic of the LCD

a. Timing condition

Signal	Parameter	Symbol	Min.	Typ.	Max	Unit.	Remark	
DCLK	DCLK period	TOSC	-	156	-	ns		
	Frequency	FOSC	-	6.4	-	MHz		
	DCLK High plus width	TCH	-	78	-	ns		
	DCLK Low plus width	TCL	-	78	-	ns		
RGB DATA	Data setup time	TSU	12	-	-	ns		
	Data hold time	THD	12	-	-	ns		
Hsync	Hsync period	TH	-	408	-	TOSC		
	Hsync pulse width	THS	5	30	-	TOSC		
	Back-Porch	THB		38		TOSC		
	Front-Porch	THF		20		TOSC		
	Hsync rising time	TCr	-	-	700	ns		
	Hsync falling time	TCf	-	-	300	ns		
Vsync	Vsync period	NTSC	-	262.5	-	TH		
		PAL	-	312.5	-	TH		
	Vsync pulse width	TVS	1	3	5	TH		
	Back-Porch	NTSC	TVB		15		TH	
		PAL			23		TH	
	Display Period	TVD		240		TH		
	Front Porch	NTSC	TVF		4.5		TH	
		PAL			46.5		TH	
	Vsync rising time	TVr	-	-	700	ns		
	Vsync falling time	TVf	-	-	1.5	μ s		
	Vsync falling to Hsync rising time for odd field	THVO	1	-	-	TOSC		
Vsync falling to Hsync falling time for even field	THVE	1	-	-	TOSC			
DEN	Vsync-DEN time	NTSC	-	18	-	TH		
		PAL	-	26	-	TH		
	Hsync-DEN time	THE	36	68	88	TOSC		
	DEN plus width	TEP	-	320	-	TOSC		

Note : If DEN is fixed to low, the SYNC mode is used. Otherwise DE mode is used. When SYNC mode is used, 1st data start from 68th CLK after Hsync falling

4 Optical specification

4.1 Optical characteristic of the LCD

Item		Symbol	Conditon	Min.	Typ.	Max.	Unit	Remark
Response Time	Rise	T_r	$\Theta = 0^\circ$	-	15	30	ms	Note 1,2,3,5
	Fall	T_f		-	35	50	ms	
Contrast ratio		CR	At optimized viewing angle	200	350	-		Note 1,2,4,5
Viewing Angle	Top		$CR \geq 10$	55	70	-	deg.	Note1,2, 5,6
	Botto m			45	60	-		
	Left			55	70	-		
	Right			55	70	-		
Brightness		Y_L	$I_{LED}=126mA,$ $25^\circ C$	240	270	-	cd/m ²	Note 7
Red chromaticity	XR	$\Theta = 0^\circ$ $\Theta = 0^\circ$	0.610	0.640	0.670	Note 7 For reference only. These data should be update according the prototype.		
	YR		0.314	0.344	0.374			
Green chromaticity	XG		0.268	0.298	0.328			
	YG		0.553	0.583	0.613			
Blue chromaticity	XB		0.102	0.132	0.162			
	YB		0.107	0.137	0.167			
White chromaticity	XW		0.282	0.312	0.342			
	YW		0.299	0.329	0.359			

() For reference only. These data should be update according the prototype.

Note 1: Ambient temperature = $25^\circ C$, and lamp current $I_{LED} = 140mA$. To be measured in the dark room.

Note 2: To be measured on the center area of panel with a viewing cone of 1° by Topcon luminance meter BM-7, after 10 minutes operation.

Note 3. Definition of response time:

The output signals of photo detector are measured when the input signals are changed from "black" to "white" (falling time) and from "white" to "black" (rising time), respectively. The response time is defined as the time interval between the 10% and 90% of amplitudes. Refer to figure as below.

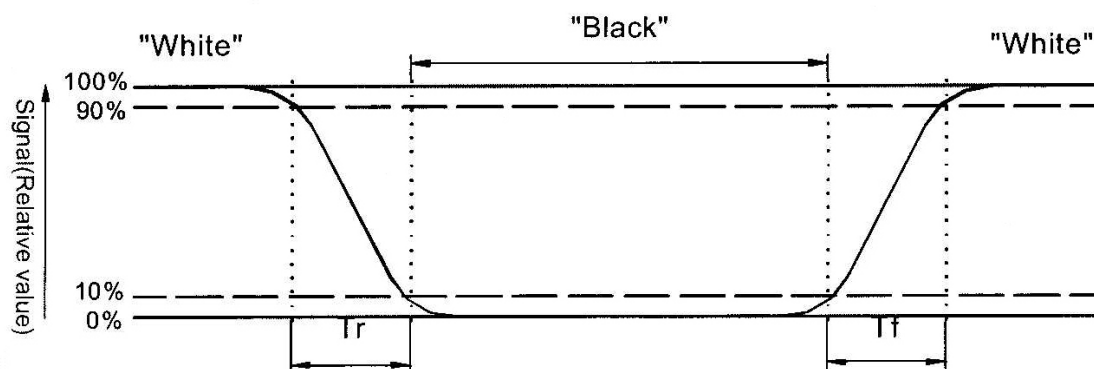

Note 4. Definition of contrast ratio:

Contrast ratio is calculated with the following formula.

$$\text{Contrast ratio(CR)} = \frac{\text{Photo detector output when LCD is at "White" state}}{\text{Photo detector Output when LCD is at "Black" state}}$$

Note 5: White $V_i = V_{i50} + 1.5V$

Black $V_i = V_{i50} + 2.0V$

“±” means that the analog input signal swings in phase with V_{COM} signal.

“ $\frac{-}{+}$ ” means that the analog input signal swings out of phase with V_{COM} signal.

V_{i50} : The analog input voltage when transmission is 50%. The 100% Transmission is defined as the transmission of LCD panel when all the Input terminals of module are electrically opened.

Note 6. Definition of viewing angle, Refer to figure as below.

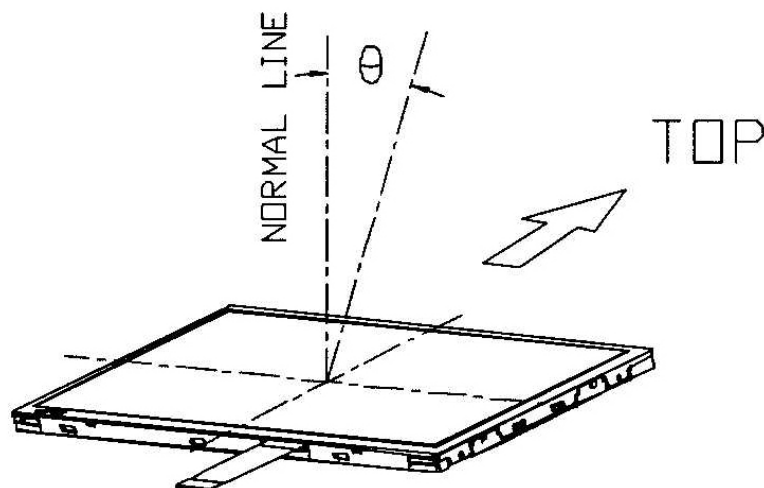

Note 7. Measured at the center area of the panel when all the input terminals of LCD panel are electrically opened.

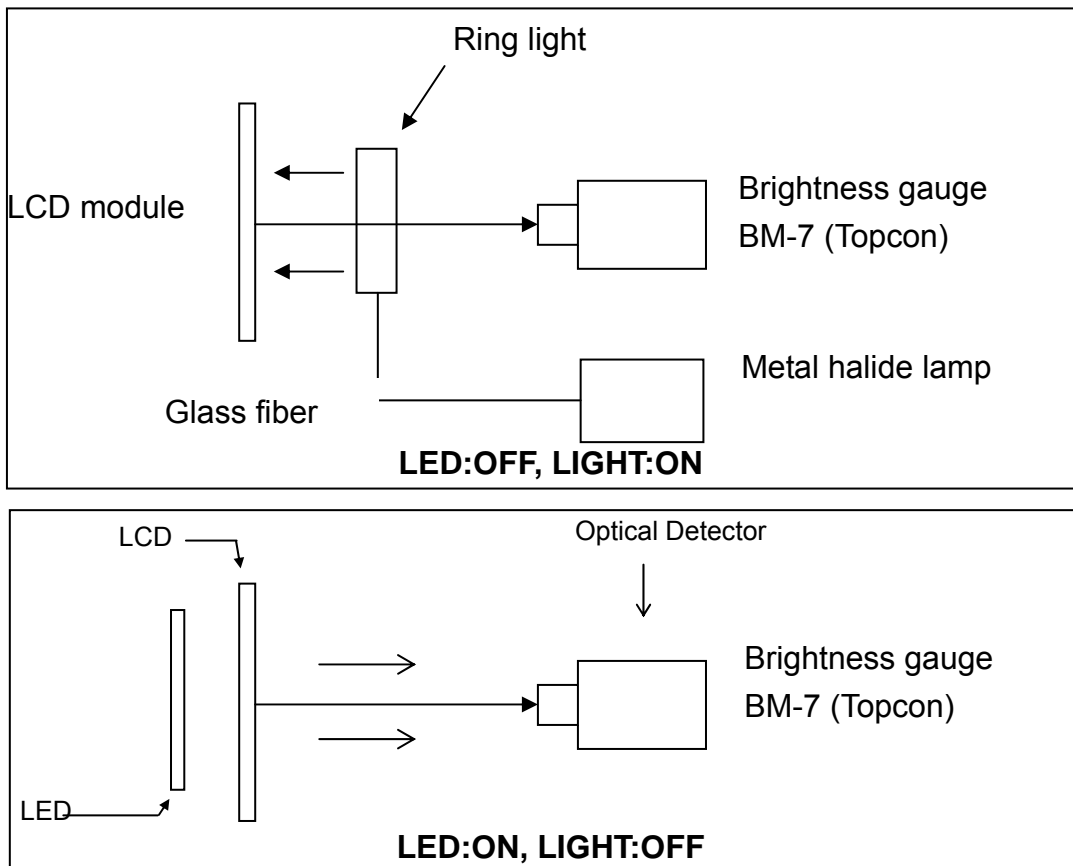

4.2 Optical characteristic of the LED Back-light

ITEM	MIN	TYP	MAX	UNIT	Condition
Bare Brightness	4000	--	--	Cd/m ²	I _{LED} = 126mA, Ta=25°C
AVG. X of 1931 C.I.E.	0.26	0.28	0.31	--	I _{LED} = 126mA, Ta=25°C
AVG. X of 1931 C.I.E.	0.27	0.29	0.32	--	I _{LED} = 126mA, Ta=25°C
Brightness Uniformity	80	--	--	%	I _{LED} = 126mA, Ta=25°C

() For reference only. These data should be update according the prototype.

Note1 : Measurement after 10 minutes from LED operating.

Note2 : Measurement of the following 9 places on the display.

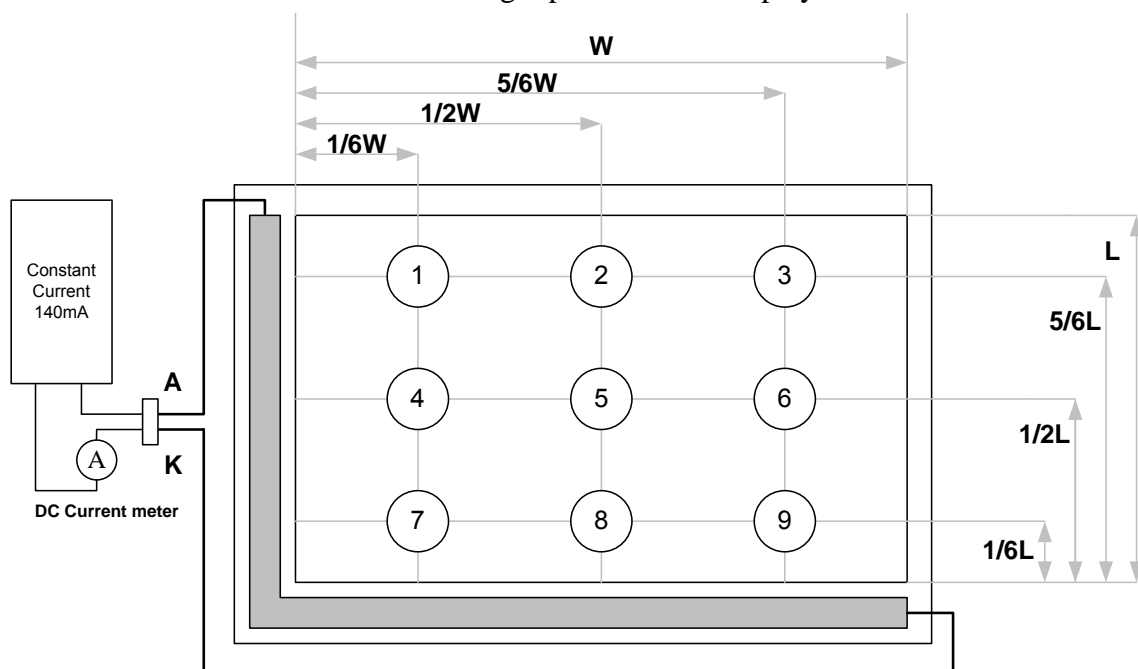

Note3: The Uniformity definition

(Min Brightness / Max Brightness) x 100%

4.3 Touch Panel Electrical Specification

Parameter	Condition	Standard Value
Terminal Resistance	X Axis	400 ~ 900 Ω
	Y Axis	200 ~ 500 Ω
Insulating Resistance	DC 25 V	More than 10MΩ
Linearity	--	±1.5 %
Notes life by Pen	Note a	100,000 times(min)

Input life by finger	Note b	1,000,000 times (min)
----------------------	--------	-----------------------

Note A .

Notes area for pen notes life test is 10 x 9 mm.

Size of word is 7.5 x 6.72

Shape of pen end : R0.8

Load : 250 g

Note B

By Silicon rubber tapping at same point

Shape of rubber end : R8

Load : 200g

Frequency : 5 Hz

Interface

No.	Symbol	Function
1	NC	No connection
2	YR	Touch Panel Right Signal
3	XB	Touch Panel Bottom Signal
4	YL	Touch Panel Left Signal
5	XT	Touch Panel Top Signal
6	NC	No connection

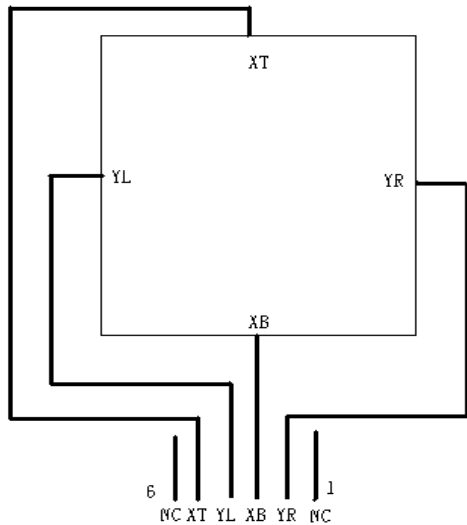

5 Interface specifications

5.1 Driving signals for the TFT panel

JAE:FA5B040HF1R3000 (Suitable FPC :t=0.3+/-0.03mm , 0.5+/-0.03mm pitch)

Pin no	Symbol	I/O	Description	Remark
1~4	VDD		Power supply for the logic (3.3V)	
5	Hsync	I	Horizontal sync input in digital RGB mode	
6	DEN	I	Input data enable control	
7	VSS		GND	
8	DCLK	I	Clock signal. Latching data at the rising edge.	
9	VSS		GND	
10	Vsync	I	Vertical sync input in digital RGB mode.	
11	VSS		GND	
12	B5	I	Blue data	
13	B4	I		
14	B3	I		
15	VSS		GND	
16	B2	I	Blue data	
17	B1	I		
18	B0	I		
19	VSS		GND	
20	G5	I	Green data	
21	G4	I		
22	G3	I		
23	VSS		GND	
24	G2	I	Green data	
25	G1	I		
26	G0	I		
27	VSS		GND	
28	R5	I	Red data	
29	R4	I		
30	R3	I		
31	VSS		GND	
32	R2	I	Red data	
33	R1	I		
34	R0	I		
35	NC		No connection	
36	VSS		GND	
37	NC		No connection	
38	NC		No connection	
39	NC		No connection	
40	NC		No connection	

5.2 Driving signals for the LED back-light

JST Housing: PHR-2

Pin no	Symbol	Level	Description	Remark
1	A	-	LED Anode	
2	K	-	LED Cathode	

Recommend LED Back-light connector:

PH CONNECTOR

Through-hole type shrouded header <Low insertion force type>

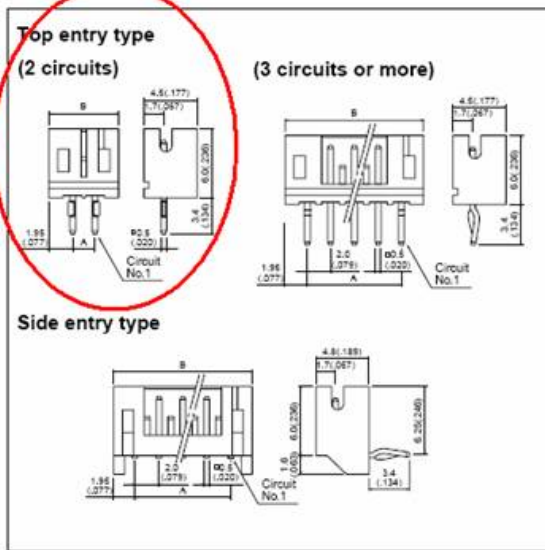

Cir- cuits	Model No.		Dimensions mm(in.)		Qty / box	
	Top entry type	Side entry type	A	B	Top entry type	Side entry type
2	B 2B-PH-KL	S 2B-PH-KL	2.0 (.079)	5.9 (.232)	1,000	1,000
3	B 3B-PH-KL	S 3B-PH-KL	4.0 (.157)	7.9 (.311)	1,000	1,000
4	B 4B-PH-KL	S 4B-PH-KL	6.0 (.235)	9.9 (.390)	1,000	500
5	B 5B-PH-KL	S 5B-PH-KL	8.0 (.315)	11.9 (.469)	1,000	500
6	B 6B-PH-KL	S 6B-PH-KL	10.0 (.394)	13.9 (.547)	1,000	500
7	B 7B-PH-KL	S 7B-PH-KL	12.0 (.472)	15.9 (.626)	500	500
8	B 8B-PH-KL	S 8B-PH-KL	14.0 (.551)	17.9 (.705)	500	250
9	B 9B-PH-KL	S 9B-PH-KL	16.0 (.630)	19.9 (.783)	500	250
10	B10B-PH-KL	S10B-PH-KL	18.0 (.709)	21.9 (.862)	500	250
11	B11B-PH-KL	S11B-PH-KL	20.0 (.787)	23.9 (.941)	500	250
12	B12B-PH-KL	S12B-PH-KL	22.0 (.866)	25.9 (1.020)	500	250
13	B13B-PH-KL	S13B-PH-KL	24.0 (.945)	27.9 (1.098)	250	250
14	B14B-PH-KL	S14B-PH-KL	26.0 (1.024)	29.9 (1.177)	250	200
15	B15B-PH-KL	S15B-PH-KL	28.0 (1.102)	31.9 (1.256)	250	200
16	B16B-PH-KL	S16B-PH-KL	30.0 (1.181)	33.9 (1.335)	250	200

Material and Finish

Post: Copper alloy, copper-undercoated, tin/lead-plated (reflow-treated)
 Wafer: Nylon 66, UL94V-0, gray

<For reference> As the color identification.

6 BLOCK DIAGRAM

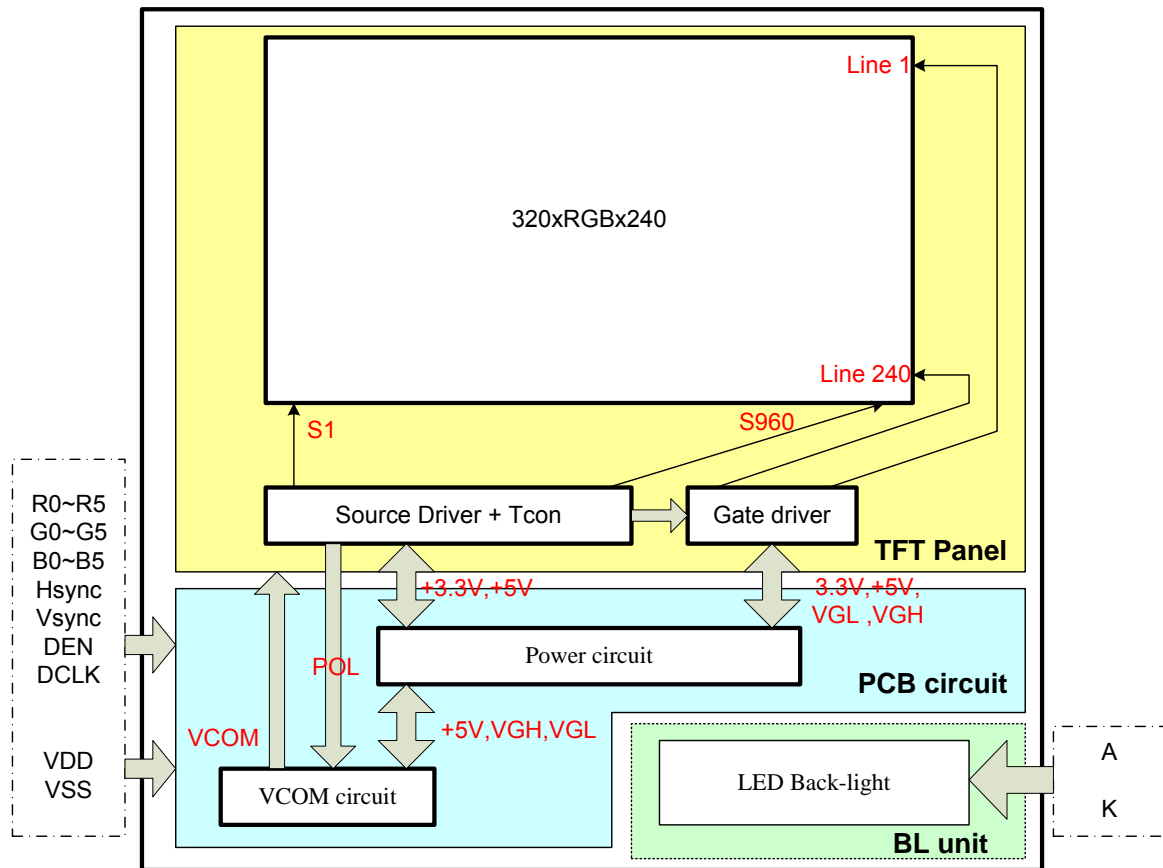

7 DISPLAYED COLOR AND INPUT DATA

	Color & Gray Scale	DATA SIGNAL																	
		R5	R4	R3	R2	R1	R0	G5	G4	G3	G2	G1	G0	B5	B4	B3	B2	B1	B0
Basic Color	Black	0	0	0	0	0	0	0	0	0	0	0	0	0	0	0	0	0	0
	Red(0)	1	1	1	1	1	1	0	0	0	0	0	0	0	0	0	0	0	0
	Green(0)	0	0	0	0	0	0	0	1	1	1	1	1	0	0	0	0	0	0
	Blue(0)	0	0	0	0	0	0	0	0	0	0	0	0	1	1	1	1	1	1
	Cyan	0	0	0	0	0	0	1	1	1	1	1	1	1	1	1	1	1	1
	Magenta	1	1	1	1	1	1	0	0	0	0	0	0	1	1	1	1	1	1
	Yellow	1	1	1	1	1	1	1	1	1	1	1	1	0	0	0	0	0	0
White	1	1	1	1	1	1	1	1	1	1	1	1	1	1	1	1	1	1	
Red	Black	0	0	0	0	0	0	0	0	0	0	0	0	0	0	0	0	0	0
	Red(62)	0	0	0	0	0	1	0	0	0	0	0	0	0	0	0	0	0	0
	Red(61)	0	0	0	0	0	1	0	0	0	0	0	0	0	0	0	0	0	0
	:	:	:	:	:	:	:	:	:	:	:	:	:	:	:	:	:	:	:
	Red(31)	0	1	1	1	1	1	0	0	0	0	0	0	0	0	0	0	0	0
:	:	:	:	:	:	:	:	:	:	:	:	:	:	:	:	:	:	:	
Red(1)	1	1	1	1	1	0	0	0	0	0	0	0	0	0	0	0	0	0	
Red(0)	1	1	1	1	1	1	0	0	0	0	0	0	0	0	0	0	0	0	
Green	Black	0	0	0	0	0	0	0	0	0	0	0	0	0	0	0	0	0	0
	Green(62)	0	0	0	0	0	0	0	0	0	0	0	1	0	0	0	0	0	0
	Green(61)	0	0	0	0	0	0	0	0	0	0	1	0	0	0	0	0	0	0
	:	:	:	:	:	:	:	:	:	:	:	:	:	:	:	:	:	:	:
	Green(31)	0	0	0	0	0	0	0	1	1	1	1	0	0	0	0	0	0	0
:	:	:	:	:	:	:	:	:	:	:	:	:	:	:	:	:	:	:	
Green(1)	0	0	0	0	0	0	1	1	1	1	1	0	0	0	0	0	0	0	
Green(0)	0	0	0	0	0	0	1	1	1	1	1	1	0	0	0	0	0	0	
Blue	Black	0	0	0	0	0	0	0	0	0	0	0	0	0	0	0	0	0	0
	Blue(62)	0	0	0	0	0	0	0	0	0	0	0	0	0	0	0	0	0	1
	Blue(61)	0	0	0	0	0	0	0	0	0	0	0	0	0	0	0	0	0	1
	:	:	:	:	:	:	:	:	:	:	:	:	:	:	:	:	:	:	:
	Blue(31)	0	0	0	0	0	0	0	0	0	0	0	0	0	1	1	1	1	1
:	:	:	:	:	:	:	:	:	:	:	:	:	:	:	:	:	:	:	
Blue(1)	0	0	0	0	0	0	0	0	0	0	0	0	1	1	1	1	1	0	
Blue(0)	0	0	0	0	0	0	0	0	0	0	0	0	1	1	1	1	1	1	

8 QUALITY AND RELIABILITY

8.1 TEST CONDITIONS

Tests should be conducted under the following conditions :

Ambient temperature : $25 \pm 5^{\circ}\text{C}$

Humidity : $60 \pm 25\% \text{ RH}$.

8.2 SAMPLING PLAN

Sampling method shall be in accordance with MIL-STD-105E , level II, normal single sampling plan .

8.3 ACCEPTABLE QUALITY LEVEL

A major defect is defined as one that could cause failure to or materially reduce the usability of the unit for its intended purpose. A minor defect is one that does not materially reduce the usability of the unit for its intended purpose or is an infringement from established standards and has no significant bearing on its effective use or operation.

8.4 APPEARANCE

An appearance test should be conducted by human sight at approximately 30 cm distance from the LCD module under fluorescent light. The inspection area of LCD panel shall be within the range of following limits.

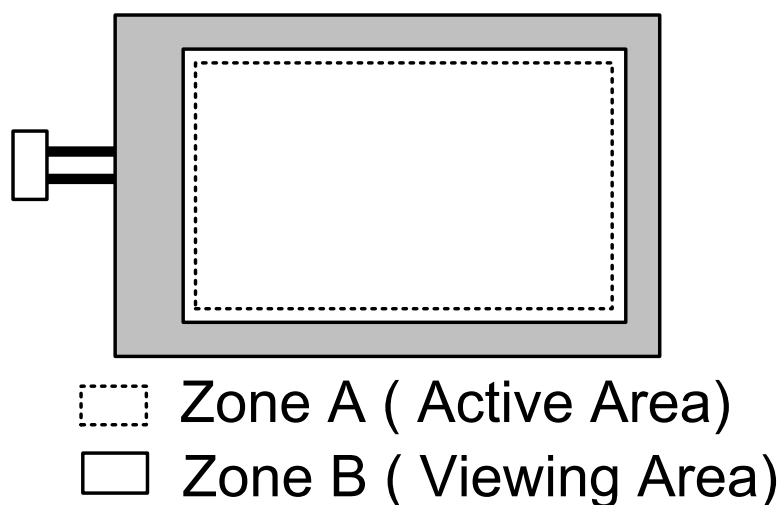

8.5 INSPECTION QUALITY CRITERIA

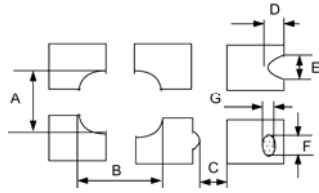
No.	Item	Criterion for defects	Defect type															
1	Non display	No non display is allowed	Major															
2	Irregular operation	No irregular operation is allowed	Major															
3	Short	No short are allowed	Major															
4	Open	Any segments or common patterns that don't activate are rejectable.	Major															
5	Black/White spot (I)	<table border="1"> <thead> <tr> <th>Size D (mm)</th> <th>Acceptable number</th> </tr> </thead> <tbody> <tr> <td>$D \leq 0.15$</td> <td>Ignore</td> </tr> <tr> <td>$0.15 < D \leq 0.20$</td> <td>3</td> </tr> <tr> <td>$0.20 < D \leq 0.30$</td> <td>2</td> </tr> <tr> <td>$0.30 < D$</td> <td>0</td> </tr> </tbody> </table>	Size D (mm)	Acceptable number	$D \leq 0.15$	Ignore	$0.15 < D \leq 0.20$	3	$0.20 < D \leq 0.30$	2	$0.30 < D$	0	Minor					
Size D (mm)	Acceptable number																	
$D \leq 0.15$	Ignore																	
$0.15 < D \leq 0.20$	3																	
$0.20 < D \leq 0.30$	2																	
$0.30 < D$	0																	
6	Black/White line (I)	<table border="1"> <thead> <tr> <th>Length(mm)</th> <th></th> <th>Acceptable number</th> </tr> </thead> <tbody> <tr> <td>$10 < L$</td> <td>$0.03 < W \leq 0.04$</td> <td>5</td> </tr> <tr> <td>$5.0 < L \leq 10$</td> <td>$0.04 < W \leq 0.06$</td> <td>3</td> </tr> <tr> <td>$1.0 < L \leq 5.0$</td> <td>$0.06 < W \leq 0.07$</td> <td>2</td> </tr> <tr> <td>$L \leq 1.0$</td> <td>$0.07 < W \leq 0.09$</td> <td>1</td> </tr> </tbody> </table>	Length(mm)		Acceptable number	$10 < L$	$0.03 < W \leq 0.04$	5	$5.0 < L \leq 10$	$0.04 < W \leq 0.06$	3	$1.0 < L \leq 5.0$	$0.06 < W \leq 0.07$	2	$L \leq 1.0$	$0.07 < W \leq 0.09$	1	Minor
Length(mm)		Acceptable number																
$10 < L$	$0.03 < W \leq 0.04$	5																
$5.0 < L \leq 10$	$0.04 < W \leq 0.06$	3																
$1.0 < L \leq 5.0$	$0.06 < W \leq 0.07$	2																
$L \leq 1.0$	$0.07 < W \leq 0.09$	1																
7	Black/White sport (II)	<table border="1"> <thead> <tr> <th>Size D (mm)</th> <th>Acceptable number</th> </tr> </thead> <tbody> <tr> <td>$D \leq 0.30$</td> <td>Ignore</td> </tr> <tr> <td>$0.30 < D \leq 0.50$</td> <td>5</td> </tr> <tr> <td>$0.50 < D \leq 1.20$</td> <td>3</td> </tr> <tr> <td>$1.20 < D$</td> <td>0</td> </tr> </tbody> </table>	Size D (mm)	Acceptable number	$D \leq 0.30$	Ignore	$0.30 < D \leq 0.50$	5	$0.50 < D \leq 1.20$	3	$1.20 < D$	0	Minor					
Size D (mm)	Acceptable number																	
$D \leq 0.30$	Ignore																	
$0.30 < D \leq 0.50$	5																	
$0.50 < D \leq 1.20$	3																	
$1.20 < D$	0																	
8	Black/White line (II)	<table border="1"> <thead> <tr> <th>Length (mm)</th> <th>Width (mm)</th> <th>Acceptable number</th> </tr> </thead> <tbody> <tr> <td>$20 < L$</td> <td>$0.05 < W \leq 0.07$</td> <td>5</td> </tr> <tr> <td>$10 < L \leq 20$</td> <td>$0.07 < W \leq 0.09$</td> <td>3</td> </tr> <tr> <td>$5.0 < L \leq 10$</td> <td>$0.09 < W \leq 0.10$</td> <td>2</td> </tr> <tr> <td>$L \leq 5.0$</td> <td>$0.10 < W \leq 0.15$</td> <td>1</td> </tr> </tbody> </table>	Length (mm)	Width (mm)	Acceptable number	$20 < L$	$0.05 < W \leq 0.07$	5	$10 < L \leq 20$	$0.07 < W \leq 0.09$	3	$5.0 < L \leq 10$	$0.09 < W \leq 0.10$	2	$L \leq 5.0$	$0.10 < W \leq 0.15$	1	Minor
Length (mm)	Width (mm)	Acceptable number																
$20 < L$	$0.05 < W \leq 0.07$	5																
$10 < L \leq 20$	$0.07 < W \leq 0.09$	3																
$5.0 < L \leq 10$	$0.09 < W \leq 0.10$	2																
$L \leq 5.0$	$0.10 < W \leq 0.15$	1																
9	Back Light	1. No Lighting is rejectable 2. Flickering and abnormal lighting are rejectable	Major															
10	Display pattern	 <table border="1"> <tbody> <tr> <td>$\frac{A+B}{2} \leq 0.30$</td> <td>$0 < C$</td> <td>$\frac{D+E}{2} \leq 0.25$</td> <td>$\frac{F+G}{2} \leq 0.25$</td> </tr> </tbody> </table> <p>Note: 1. Acceptable up to 3 damages 2. NG if there're to two or more pinholes per dot</p>	$\frac{A+B}{2} \leq 0.30$	$0 < C$	$\frac{D+E}{2} \leq 0.25$	$\frac{F+G}{2} \leq 0.25$	Minor											
$\frac{A+B}{2} \leq 0.30$	$0 < C$	$\frac{D+E}{2} \leq 0.25$	$\frac{F+G}{2} \leq 0.25$															

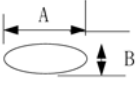
11	Blemish & Foreign matters Size: $D = \frac{A+B}{2}$	Size D (mm)		Acceptable number	Minor		
		$D \leq 0.15$	Ignore				
		$0.15 < D \leq 0.20$	3				
		$0.20 < D \leq 0.30$	2				
		$0.30 < D$	0				
12	Scratch on Polarizer 	Width (mm)			Length (mm)	Acceptable number	Minor
		$W \leq 0.03$	Ignore		Ignore		
		$0.03 < W \leq 0.05$	$L \leq 2.0$		Ignore		
		$0.05 < W \leq 0.08$	$L > 2.0$		1		
		$0.08 < W$	$L > 1.0$		1		
			$L \leq 1.0$		Ignore		
			Note (1)		Note(1)		
		Note(1) Regard as a blemish					
13	Bubble in polarizer	Size D (mm)		Acceptable number	Minor		
		$D \leq 0.20$	Ignore				
		$0.20 < D \leq 0.50$	3				
		$0.50 < D \leq 0.80$	2				
		$0.80 < D$	0				
14	Stains on LCD panel surface	Stains that cannot be removed even when wiped lightly with a soft cloth or similar cleaning tool are rejectable.			Minor		
15	Rust in Bezel	Rust which is visible in the bezel is rejectable.			Minor		
16	Defect of land surface contact (poor soldering)	Evident crevices which is visible are rejectable.			Minor		
17	Parts mounting	1. Failure to mount parts 2. Parts not in the specifications are mounted 3. Polarity, for example, is reversed			Major Major Major		
18	Parts alignment	1. LSI, IC lead width is more than 50% beyond pad outline.			Minor		
		2. Chip component is off center and more than 50% of the leads is off the pad outline.			Minor		
19	Conductive foreign matter (Solder ball, Solder chips)	1. $0.45 < \varphi$, $N \geq 1$			Major		
		2. $0.30 < \varphi \leq 0.45$, $N \geq 1$ φ : Average diameter of solder ball (unit: mm)			Minor		
		3. $0.50 < L$, $N \geq 1$ L: Average length of solder chip (unit: mm)			Minor		
20	Faulty PCB correction	1. Due to PCB copper foil pattern burnout, the pattern is connected, using a jumper wire for repair; 2 or more places are corrected per PCB.			Minor		
		2. Short circuited part is cut, and no resist coating has been performed.			Minor		

21	Defect Dot	The TFT panel may have bright dot or Dark dot. The acceptable number defection:				Minor
		Bright dot	Dark dot	Total dot	Distance between Dark-- dark	
		2	3	4	$L \geq 5$ mm	

9 Reliability test items (Note2):

No.	Test items	Conditions	Remark
1	High temperature storage	Ta=80°C 240Hrs	
2	Low temperature storage	Ta=-30°C 240Hrs	
3	High temperature operation	Ta=70°C 240Hrs	
4	Low temperature operation	Ta=-20°C 240Hrs	
5	High temperature and high humidity	Ta=40°C, 85% RH 240Hrs	Operation
6	Heat shock	-30°C~80°C/200 cycles 1Hrs/cycle	Non-operation
7	Electrostatic discharge	±200V, 200Pf(0Ω), once for each terminal	Non-operation
8	Vibration	Frequency range :8~33.3Hz Stoke :1.3mm Sweep :2.9G, 33.3~400Hz Cycle :15 minutes 2 hours for each direction of X,Z 4 hours for Y direction	JIS C7021, A-10 Condition A
9	Mechanical shock	100G, 6ms, ±X, ±Y, ±Z 3 times for each direction	JIS C7021, A-7 Condition C
10	Vibration (With carton)	Random vibration: 0.015G ² /Hz from 5~200Hz -6dB/octave from 200~500Hz	IEC 68~34
11	Drop (with carton)	Height:60cm 1 corner, 3 edges, 6 surfaces	JIS Z0202

10 USE PRECAUTIONS

10.1 Handling precautions

- 1) The polarizing plate may break easily so be careful when handling it. Do not touch, press or rub it with a hard-material tool like tweezers.
- 2) Do not touch the polarizing plate surface with bare hands so as not to make it dirty. If the surface or other related part of the polarizing plate is dirty, soak a soft cotton cloth or chamois leather in benzine and wipe off with it. Do not use chemical liquids such as acetone, toluene and isopropyl alcohol. Failure to do so may bring chemical reaction phenomena and deteriorations.
- 3) Remove any spit or water immediately. If it is left for hours, the suffered part may deform or decolorize.
- 4) If the LCD element breaks and any LC stuff leaks, do not suck or lick it. Also if LC stuff is stuck on your skin or clothing, wash thoroughly with soap and water immediately.

10.2 Installing precautions

- 1) The PCB has many ICs that may be damaged easily by static electricity. To prevent breaking by static electricity from the human body and clothing, earth the human body properly using the high resistance and discharge static electricity during the operation. In this case, however, the resistance value should be approx. $1M\Omega$ and the resistance should be placed near the human body rather than the ground surface. When the indoor space is dry, static electricity may occur easily so be careful. We recommend the indoor space should be kept with humidity of 60% or more. When a soldering iron or other similar tool is used for assembly, be sure to earth it.
- 2) When installing the module and ICs, do not bend or twist them. Failure to do so may crack LC element and cause circuit failure.
- 3) To protect LC element, especially polarizing plate, use a transparent protective plate (e.g., acrylic plate, glass etc) for the product case.
- 4) Do not use an adhesive like a both-side adhesive tape to make LCD surface (polarizing plate) and product case stick together. Failure to do so may cause the polarizing plate to peel off.

10.3 Storage precautions

- 1) Avoid a high temperature and humidity area. Keep the temperature between 0°C and 35°C and also the humidity under 60%.
- 2) Choose the dark spaces where the product is not exposed to direct sunlight or fluorescent light.

- 3) Store the products as they are put in the boxes provided from us or in the same conditions as we recommend.

10.4 Operating precautions

- 1) Do not boost the applied drive voltage abnormally. Failure to do so may break ICs. When applying power voltage, check the electrical features beforehand and be careful. Always turn off the power to the LC module controller before removing or inserting the LC module input connector. If the input connector is removed or inserted while the power is turned on, the LC module internal circuit may break.
- 2) The display response may be late if the operating temperature is under the normal standard, and the display may be out of order if it is above the normal standard. But this is not a failure; this will be restored if it is within the normal standard.
- 3) The LCD contrast varies depending on the visual angle, ambient temperature, power voltage etc. Obtain the optimum contrast by adjusting the LC drive voltage.
- 4) When carrying out the test, do not take the module out of the low-temperature space suddenly. Failure to do so will cause the module condensing, leading to malfunctions.
- 5) Make certain that each signal noise level is within the standard (L level: $0.2V_{dd}$ or less and H level: $0.8V_{dd}$ or more) even if the module has functioned properly. If it is beyond the standard, the module may often malfunction. In addition, always connect the module when making noise level measurements.
- 6) The CMOS ICs are incorporated in the module and the pull-up and pull-down function is not adopted for the input so avoid putting the input signal open while the power is ON.
- 7) The characteristic of the semiconductor element changes when it is exposed to light emissions, therefore ICs on the LCD may malfunction if they receive light emissions. To prevent these malfunctions, design and assemble ICs so that they are shielded from light emissions.
- 8) Crosstalk occurs because of characteristics of the LCD. In general, crosstalk occurs when the regularized display is maintained. Also, crosstalk is affected by the LC drive voltage. Design the contents of the display, considering crosstalk.

10.5 Other

- 1) Do not disassemble or take the LC module into pieces. The LC modules once disassembled or taken into pieces are not the guarantee articles.
- 2) The residual image may exist if the same display pattern is shown for hours. This residual image, however, disappears when another display pattern is shown or the drive is interrupted and left for a while. But this is not a problem on reliability.
- 3) AMIPRE will provide one year warranty for all products and three months warrantee for all repairing products.

11 OUTLINE DIMENSION

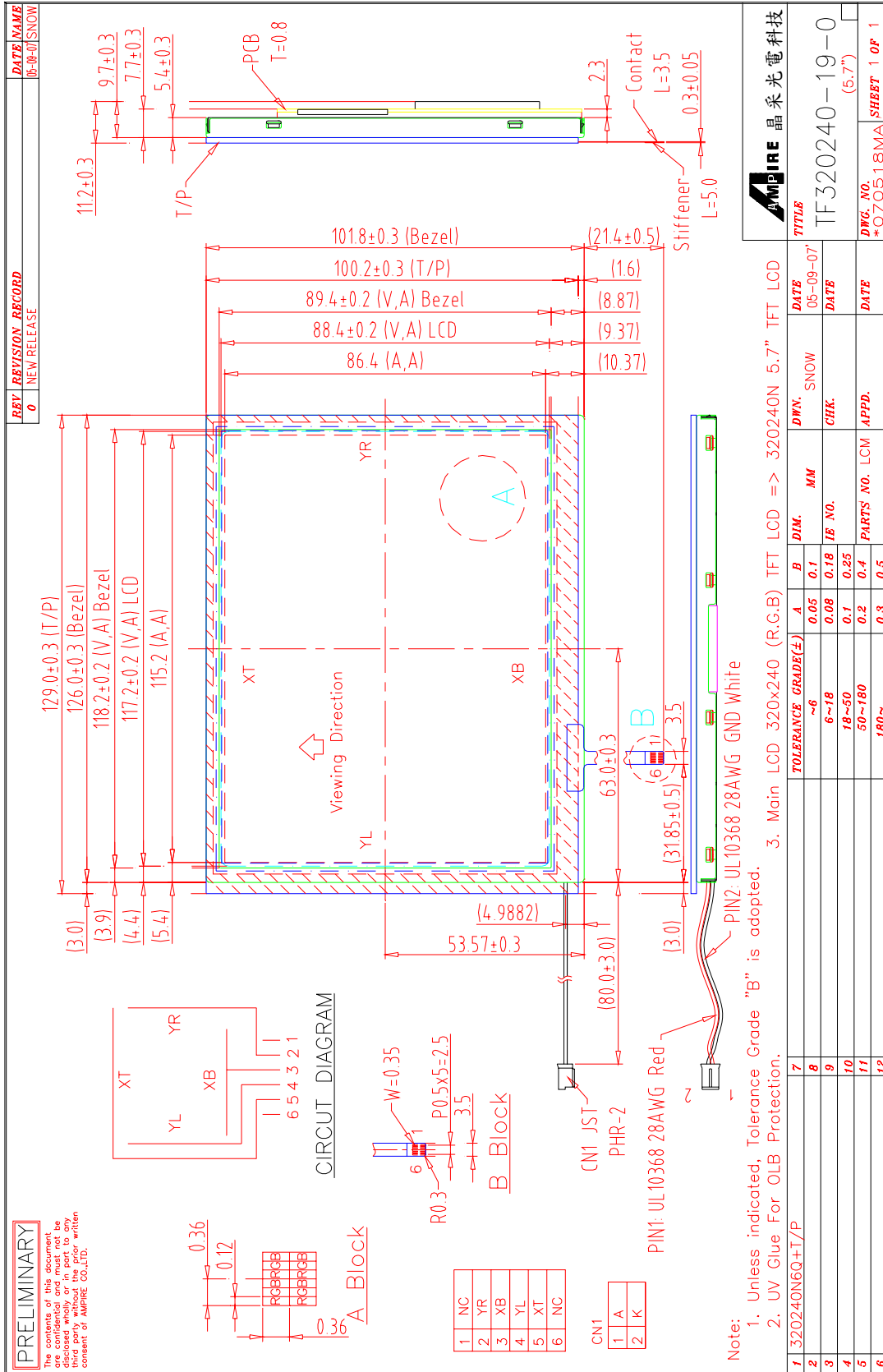

REV	REVISION RECORD	DATE	NAME
0	NEW RELEASE	05-09-07	SNOW

PRELIMINARY
 The contents of this document are confidential and must not be disclosed wholly or in part to any third party without the prior written consent of AMPIRE CO.,LTD.

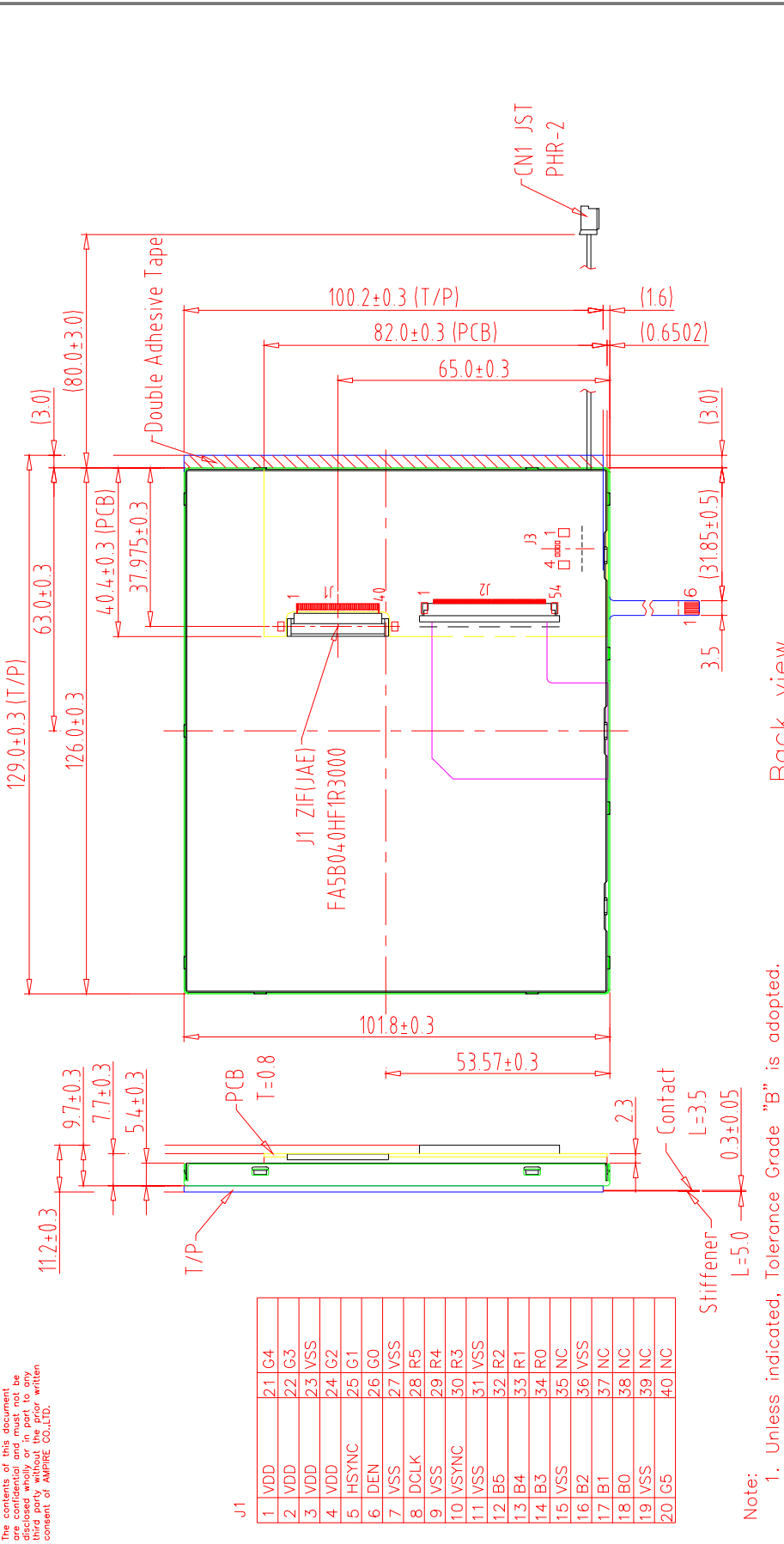

J1

1	VDD	21	G4
2	VDD	22	G3
3	VDD	23	VSS
4	VDD	24	G2
5	HSYNC	25	G1
6	DEN	26	G0
7	VSS	27	VSS
8	DCLK	28	R5
9	VSS	29	R4
10	VSYNC	30	R3
11	VSS	31	VSS
12	IB5	32	R2
13	IB4	33	R1
14	IB3	34	RO
15	VSS	35	NC
16	IB2	36	VSS
17	IB1	37	NC
18	IB0	38	NC
19	VSS	39	NC
20	IG5	40	NC

- Note:
1. Unless indicated, Tolerance Grade "B" is adopted.
 2. UV Glue For OLB Protection.
 3. Main LCD 320x240 (R.G.B) TFT LCD => 320240N 5.7" TFT LCD

Back view

AMPIRE 晶采光電科技
TITLE
TF320240-19-0
(5.7")
DWG. NO. *070519MA
SHEET 1 OF 1

1	320240N6Q+T/P	7	TOLERANCE GRADE(±)	A	B	DIM.	MM	DNW.	SNOW	DATE
2		8	~6	0.05	0.1	0.08	0.18	CHK.	CHK.	05-09-07
3		9	6~18	0.08	0.1	0.1	0.25			
4		10	18~50	0.1	0.2	0.2	0.4	PARTS NO. LCM-1	APPD.	
5		11	50~180	0.2	0.3	0.3	0.5			
6		12	180~							