



晶采光電科技股份有限公司
AMPIRE CO., LTD.

SPECIFICATIONS FOR LCD MODULE

CUSTOMER	
CUSTOMER PART NO.	
AMPIRE PART NO.	AM-19201080FTZQW-00
APPROVED BY	
DATE	

Approved For Specifications

Approved For Specifications & Sample

AMPIRE CO., LTD.

**4F., No.116, Sec. 1, Xintai 5th Rd., Xizhi Dist., New Taipei
City221, Taiwan (R.O.C.)**

新北市汐止區新台五路一段 116 號 4 樓(東方科學園區 A 棟)

TEL:886-2-26967269 , FAX:886-2-26967196 or 26967270

APPROVED BY	CHECKED BY	ORGANIZED BY

1.0 General Descriptions

1.1 Introduction

The LCM is a color active matrix TFT LCD module using amorphous silicon TFT's (Thin Film Transistors) as an active switching devices. This module has a 15.6 inch diagonally measured active area with FHD resolutions (1920 horizontal by 1080 vertical pixel array). Each pixel is divided into RED, GREEN, BLUE dots which are arranged in vertical Stripe and this module can display 16.7M colors. The TFT-LCD panel used for this module is a low reflection and higher color type.

1.2 Features

- 3.3 V Logic Power
- [2 lane eDP Interface with 2.7Gbps Link Rates](#)
- 16.7M Colors (6bit + HFRC)
- On board LED Driving circuit
- Green Product (RoHS)

1.3 Product Summary

Items	Specifications	Unit
Screen Diagonal	15.6	Inch
Active Area	344.16 (H) ×193.59 (V)	mm
Pixel Format	1920 (H) x RGB x 1080 (V)	-
Pixel Pitch	0.17925 (H) X 0.17925 (V)	mm
Pixel Arrangement	R.G.B. Vertical Stripe	-
Display Mode	Normally Black	-
White Luminance	500 (Typ)	cd /m2
Contrast Ratio	800 : 1 (Typ)	-
Input Voltage	3.3	V
Outline Dimensions	363.8(H)(Typ)*215.9V) (Typ)(W/PCB)*9.9(Max)	mm
Support Color	16.7M (6bit + HFRC)	-

1.4 Functional Block Diagram

Shows the functional block diagram of the LCD module.

Figure 1 Block Diagram

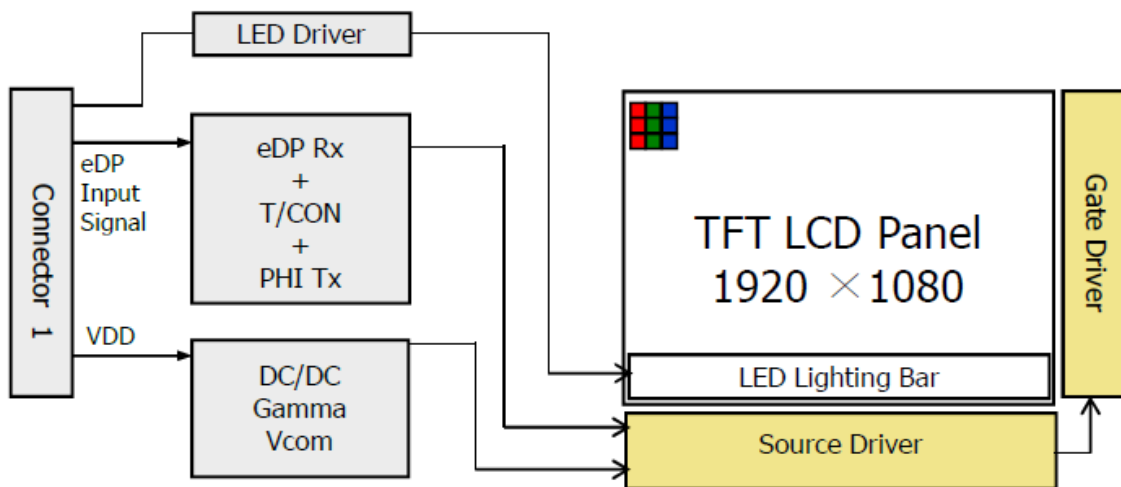

2.0 Absolute Maximum Ratings

ITEM	SYMBOL	VALUES		UNIT	REMARK
		MIN	MAX		
Power Supply Voltage	VDD	-0.3	+4.0	V	
Logic Supply Voltage	Vin	Vss-0.3	VDD+0.3	V	
Operation Temperature	T _{op}	-30	75	°C	
Storage Temperature	T _{st}	-30	80	°C	

Notes : 1. Permanent damage to the device may occur if maximum values are exceeded functional operation should be restricted to the condition described under normal operating conditions.

2. Temperature and relative humidity range are shown in the figure below.

95 % RH Max. (40 OC ≥ Ta)

Maximum wet - bulb temperature at 39 OC or less. (Ta > 40 OC) No condensation.

3.0 Electrical Specifications

3.0 ELECTRICAL SPECIFICATIONS

Table 3 Electrical Specifications

Parameter		Min.	Typ.	Max.	Unit	Remarks
Power Supply Voltage	V_{DD}	3.0	3.3	3.6	V	Note 1
Permissible Input Ripple Voltage	V_{RF}	-	-	100	mV	At $V_{DD} = 3.3V$
Power Supply Current	I_{DD}	-	300	-	mA	Note 1
Differential Input Voltage	V_{ID}	200	-	600	mV	
Power Consumption	P_D	-	1.0	2.3	W	Note 1
	P_{BL}	-	-	5.7	W	Note 2
	P_{total}	-	-	8.0	W	

Notes : 1. The supply voltage is measured and specified at the interface connector of LCM.

The current draw and power consumption specified is for 3.3V at 25°C.

a) Typ : Mosaic Pattern

b) Max : R/G/B Pattern



2. Calculated value for reference ($V_{LED} \times I_{LED}$)

4. Interface Timings

4.1 Timing Characteristics

Item		Symbols	Min	Typ	Max	Unit
Clock	Frequency	1/Tc	100	141.4	160	MHz
	High Time	Tch	-	4/7	-	Tc
	Low Time	Tcl	-	3/7	-	Tc
Frame Period		Tv	1090	1100	1238	lines
			-	60	-	Hz
			-	16.7	-	ms
Vertical Display Period		Tvd	-	1080	-	lines
One line Scanning Period		Th	2080	2142	2400	clocks
Horizontal Display Period		Thd	-	1920	-	clocks

Note*: This Module can support low frame refresh rate 50Hz & 40Hz.

4.2 Timing diagram

The specification of the eDP Rx interface timing parameter is shown in Table 8.

<Table 8. eDP Rx Interface Timing Specification>

Item	Symbol	Min	Typ	Max	Unit	Remark
Spread spectrum clock	ssc		0.5		%	
Differential peak-to-peak input voltage at package pins	VRX-DIFFp-p	100	0	1320	mV	
Rx input DC common mode voltage	VRX_DC_CM	-	GND	-	V	
Differential termination resistance	RRX-DIFF	80	-	100	Ω	
Single-ended termination resistance	RRX-SE	40	-	60	Ω	
Rx short circuit current limit	IRX_SHORT	-	-	20	mA	
Intra-pair skew at Rx package pins (HBR) RX intra-pair skew tolerance at HBR	LRX_SKEW_INTRA_PAIR	-	-	150	ps	

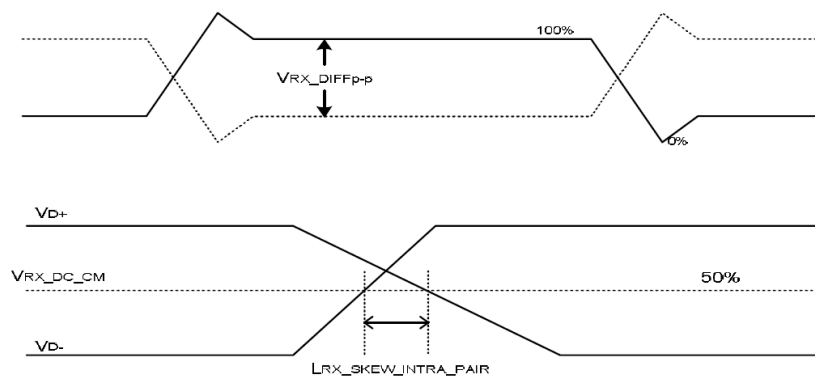

4.3 Power Sequence

To prevent a latch-up or DC operation of the LCD module, the power on/off sequence shall be as shown below.

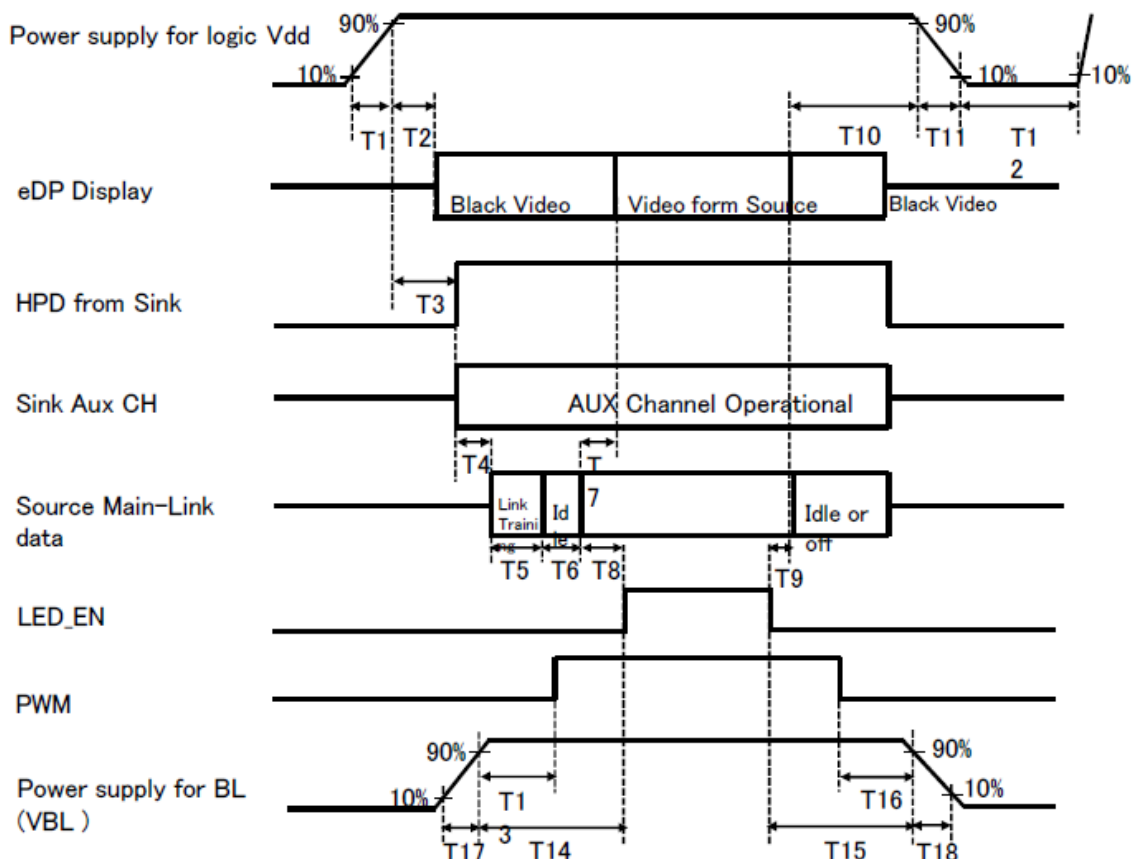

- 0.5ms ≤ T1 ≤ 10 ms
- 0ms ≤ T2 ≤ 200 ms
- 0ms ≤ T3 ≤ 200 ms
- 0ms ≤ T13
- 0ms ≤ T14
- 0ms ≤ T17
- 0ms ≤ T7 ≤ 50ms
- 0ms ≤ T10 ≤ 500 ms
- 0 ms ≤ T11 ≤ 10 ms
- 150ms ≤ T12
- 0ms ≤ T15
- 0ms ≤ T16
- 0ms ≤ T18

Notes:

1. When the power supply VDD is 0V, keep the level of input signals on the low or keep high impedance.
2. Do not keep the interface signal high impedance when power is on. Back Light must be turn on after power for logic and interface signal are valid.

5.0 Optical Specifications

The optical characteristics are measured under stable conditions as following notes

Item	Conditions		Min.	Typ.	Max.	Unit	Note
Viewing Angle (CR>10)	Horizontal	θ_L	80	85	-	degree	Note1
		θ_R	80	85	-		
	Vertical	θ_T	80	85	-		
		θ_B	80	85	-		
Contrast Ratio	Center		-	800	-	-	Note2
Response Time	Rising + Falling		-	30	35	ms	Note5
Color Chromaticity (CIE1931)	Red	x	Typ. -0.05	0.616	Typ. +0.05	-	Note3
	Red	y		0.339		-	
	Green	x		0.313		-	
	Green	y		0.582		-	
	Blue	x		0.156		-	
	Blue	y		0.134		-	
	White	x		0.313		-	
	White	y		0.329		-	
White Luminance	Center		420	500	-	cd/m ²	Note4
Luminance Uniformity	9Points		75	-	-	%	Note4
Cross Talk	CT	$\Theta=0$	-	-	2.0	%	Note6

Notes 1 : Viewing angle is the angle at which the contrast ratio is greater than 10.

The viewing angles are determined for the horizontal or 3, 9 o'clock direction and the vertical or 6, 12 o'clock direction with respect to the optical axis which is normal to the LCD surface(see Figure1).

Notes 2 : Contrast measurements shall be made at viewing angle of $\Theta=0$ and at the center of the LCD surface. Luminance shall be measured with all pixels in the view field set first to white, then to the dark (black) state (see Figure1).

Luminance Contrast Ratio (CR) is defined mathematically as $CR = \text{Luminance when displaying a white raster} / \text{Luminance when displaying a black raster}$.

Notes 3 : Reference only / Standard Front Surface Treatment Measured with green cover glass. The color chromaticity coordinates specified in Table 4 shall be calculated from the spectral data measured with all pixels first in red, green, blue and white. Measurements shall be made at the center of the panel.

Figure 1. Measurement Set Up

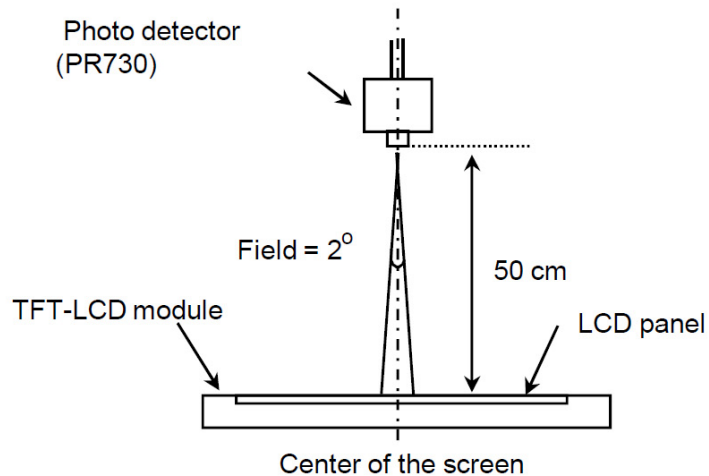

Optical characteristics measurement setup

Figure 2. White Luminance and Uniformity Measurement Locations (9 points)

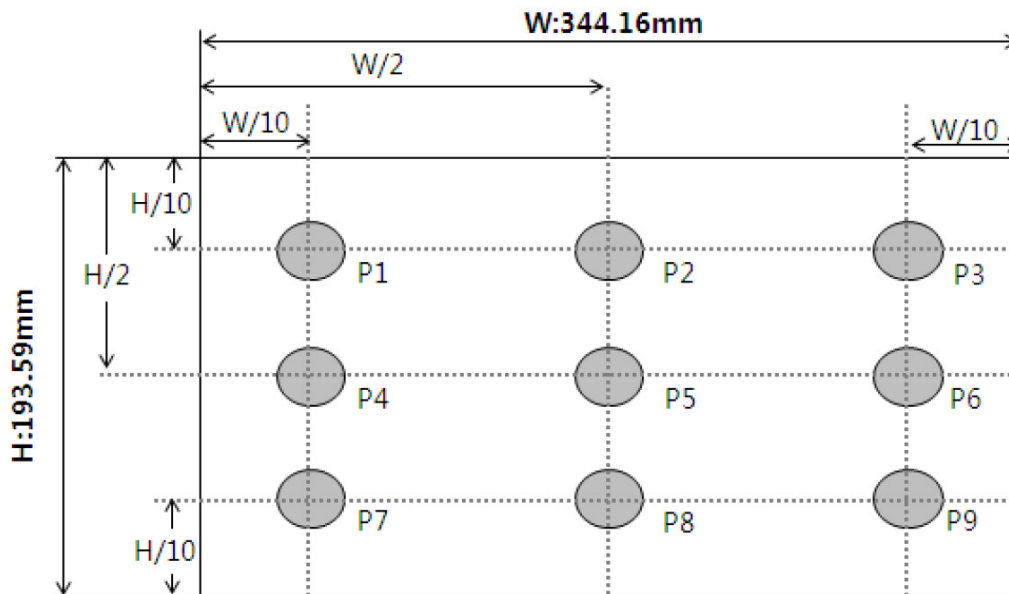

Center Luminance of white is defined as luminance values of center 9 points across the LCD surface. Luminance shall be measured with all pixels in the view field set first to white. This measurement shall be taken at the locations shown in FIGURE 2 for a total of the measurements per display.

Figure 3. Response Time Testing

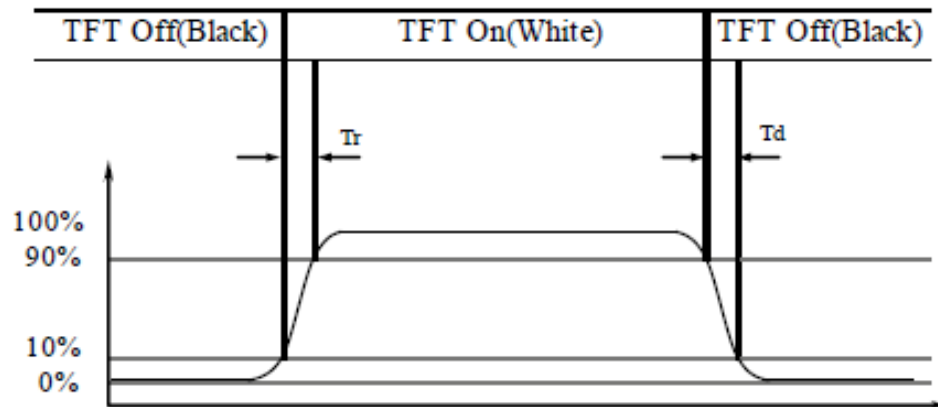

Note 5.

The electro-optical response time measurements shall be made as Figure 4 by switching the "data" input signal ON and OFF. The times needed for the luminance to change from 10% to 90% is T_r , and 90% to 10% is T_d .

Note 6.

Cross-Talk of one area of the LCD surface by another shall be measured by comparing the luminance (YA) of a 25mm diameter area, with all display pixels set to a gray level, to the luminance (YB) of that same area when any adjacent area is driven dark (Refer to Figure 4).

Figure 4. Cross Modulation Test Description

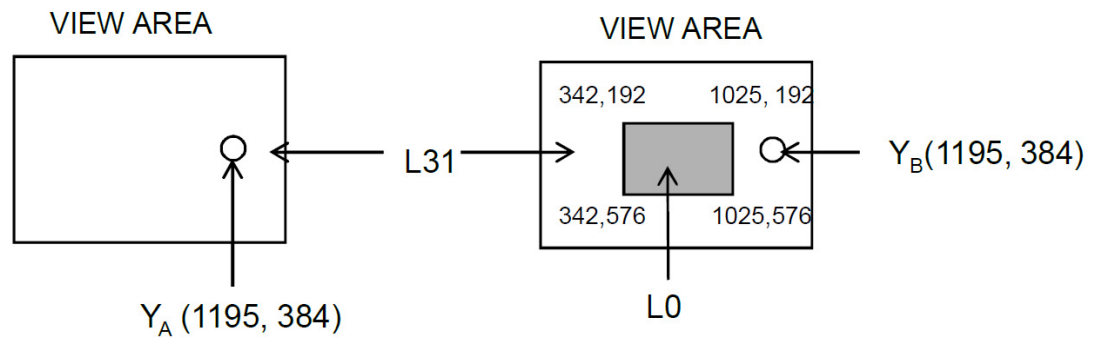

$$\text{Cross-Talk (\%)} = \left| \frac{Y_B - Y_A}{Y_A} \right| \times 100$$

Where:

Y_A = Initial luminance of measured area (cd/m²)

Y_B = Subsequent luminance of measured area (cd/m²)

The location measured will be exactly the same in both patterns

Cross-Talk of one area of the LCD surface by another shall be measured by comparing the luminance (YA) of a 25mm diameter area, with all display pixels set to a gray level, to the luminance (YB) of that same area when any adjacent area is driven dark (Refer to FIGURE 4).

6. Interface Connections

6.1 Electrical Interface Connector:STMMSAK24025P30

Terminal	Symbol	Functions
Pin No.	Symbol	Description
1	NC	No Connection
2	H_GND	Ground
3	LANE1_N	eDP RX channel 1 negative
4	LANE1_P	eDP RX channel 1 positive
5	H_GND	Ground
6	LANE0_N	eDP RX channel 0 negative
7	LANE0_P	eDP RX channel 0 positive
8	H_GND	Ground
9	AUX_CH_P	eDP AUX CH positive
10	AUX_CH_N	eDP AUX CH negative
11	H_GND	Ground
12	LCD_VCC	Power Supply, 3.3V (typ.)
13	LCD_VCC	Power Supply, 3.3V (typ.)
14	LCD_Self_Test	Panel self test enable
15	H_GND	Ground
16	H_GND	Ground
17	HPD	Hot plug detect output
18	BL_GND	LED Ground
19	BL_GND	LED Ground
20	BL_GND	LED Ground
21	BL_GND	LED Ground
22	BL_ENABLE	LED enable pin(+3.3V Input)
23	BL_PWM	System PWM Signal Input
24	NC	No Connection
25	NC	No Connection
26	BL_POWER	LED Power Supply 12V
27	BL_POWER	LED Power Supply 12V
28	BL_POWER	LED Power Supply 12V
29	BL_POWER	LED Power Supply 12V
30	NC	No Connection

6.2 eDP Interface

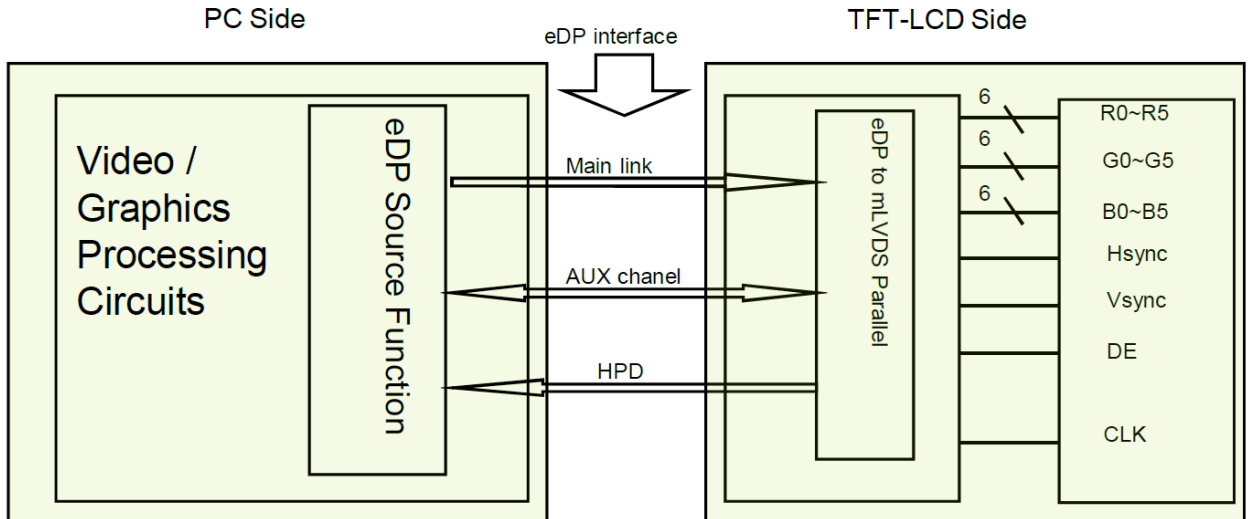

Note. Transmitter : HX8876-G04 or equivalent.

Transmitter is not contained in Module.

eDP Input signal

Lane 0	Lane 1
R0-5:0 G0-5:4	R1-5:0 G1-5:4
G0-3:0 B0-5:2	G1-3:0 B1-5:2
B0-1:0 R2-5:0	B1-1:0 R3-5:0
G2-5:0 B2-5:4	G3-5:0 B3-5:4
B2-3:0 R4-5:2	B3-3:0 R5-5:2
R4-1:0 G4-5:0	R5-1:0 G5-5:0
B4-5:0 R6-5:4	B5-5:0 R7-5:4
R6-3:0 G6-5:2	R7-3:0 G7-5:2
R6-1:0 G6-5:0	R7-1:0 G7-5:0

7. LED Driving Conditions

< Table 4. LED Driving guideline specifications >

Ta=25+/-2°C

Parameter		Min.	Typ.	Max.	Unit	Remarks
LED Forward Voltage	V _F	-	3.0	3.2	V	-
LED Forward Current	I _F	-	50	-	mA	-
LED Power Consumption	P _{LED}		-	5.7	W	Note 1
LED Life-Time	N/A	50,000	-	-	Hour	Note2
Power supply voltage for LED Driver		V _{LED}	10.8	12	13.2	V
EN Control Level	Backlight on		2.5		5.0	V
	Backlight off		0		0.8	V
PWM Control Level	PWM High Level		2.5		5.0	V
	PWM Low Level		0		0.8	V
PWM Control Frequency		F _{PWM}	120	-	1,000	Hz
Duty Ratio		-	10	-	100	%

Notes : 1. Power supply voltage 12V for LED Driver

Calculator Value for reference $I_F \times V_F \times 32 / \text{efficiency} = P_{LED}$

2. The LED Life-time define as the estimated time to 50% degradation of initial luminous@25°C.

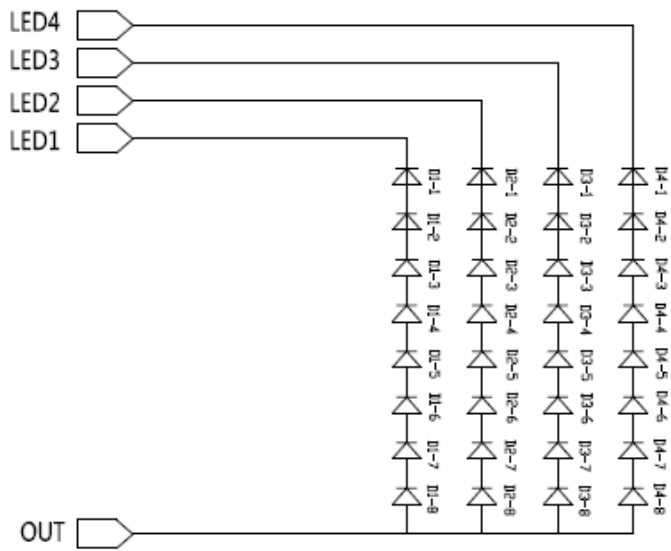

8. Reliability Test

The reliability test items and its conditions are shown below.

Test Item	Test Conditions	Note
High Temperature Operation	75±3°C , t=240 hrs	
Low Temperature Operation	-30±3°C , t=240 hrs	
High Temperature Storage	80±3°C , t=240 hrs	1,2
Low Temperature Storage	-30±3°C , t=240 hrs	1,2
Storage at High Temperature and Humidity	40°C, 90% RH , 240 hrs	1,2
Thermal Shock Test	-30°C (30min) ~ 60°C (30min) , 27 cycles	1,2
Vibration Test (Packing)	Sweep frequency : 10~55~10 Hz/1min Amplitude : 0.75mm Test direction : X.Y.Z/3 axes Duration : 30 min/each axis	2

Note (1) Condensation of water is not permitted on the module.

Note (2) The module should be inspected after 1 hour storage in normal conditions (15-35°C, 45-65%RH).

9 . GENERAL PRECAUTION

9.1 Use Restriction

This product is not authorized for use in life supporting systems, aircraft navigation control systems, military systems and any other application where performance failure could be life-threatening or otherwise catastrophic.

9.2 Disassembling or Modification

Do not disassemble or modify the module. It may damage sensitive parts inside LCD module, and may cause scratches or dust on the display. AMPIRE does not warrant the module, if customers disassemble or modify the module.

9.3 Breakage of LCD Panel

- (1) If LCD panel is broken and liquid crystal spills out, do not ingest or inhale liquid crystal, and do not contact liquid crystal with skin.
- (2) If liquid crystal contacts mouth or eyes, rinse out with water immediately.
- (3) If liquid crystal contacts skin or cloths, wash it off immediately with alcohol and rinse thoroughly with water.
- (4) Handle carefully with chips of glass that may cause injury, when the glass is broken.

9.4 Electric Shock

- (1) Disconnect power supply before handling LCD module.
- (2) Do not pull or fold the LED cable.
- (3) Do not touch the parts inside LCD modules and the fluorescent LED's connector or cables in order to prevent electric shock.

9.5 Absolute Maximum Ratings and Power Protection Circuit

- (1) Do not exceed the absolute maximum rating values, such as the supply voltage variation, input voltage variation, variation in parts' parameters, environmental temperature, etc., otherwise LCD module may be damaged.
- (2) Please do not leave LCD module in the environment of high humidity and high temperature for a long time.
- (3) It's recommended to employ protection circuit for power supply.

9.6 Operation

- (1) Do not touch, push or rub the polarizer with anything harder than HB pencil lead.
- (2) Use fingerstalls of soft gloves in order to keep clean display quality, when persons handle the LCD module for incoming inspection or assembly.
- (3) When the surface is dusty, please wipe gently with absorbent cotton or other soft material.
- (4) Wipe off saliva or water drops as soon as possible. If saliva or water drops contact with polarizer for a long time, they may cause deformation or color fading.
- (5) When cleaning the adhesives, please use absorbent cotton wetted with a little petroleum benzene or other adequate solvent.

9.7 Mechanism

Please mount LCD module by using mounting holes arranged in four corners tightly.

9.8 Static Electricity

- (1) Protection film must remove very slowly from the surface of LCD module to prevent from electrostatic occurrence.
- (2) Because LCD modules use CMOS-IC on circuit board and TFT-LCD panel, it is very weak to electrostatic discharge. Please be careful with electrostatic discharge. Persons who handle the module should be grounded through adequate methods.

9.9 Strong Light Exposure

The module shall not be exposed under strong light such as direct sunlight. Otherwise, display characteristics may be changed.

9.10 Disposal

When disposing LCD module, obey the local environmental regulations.

9.11 Others

Do not keep the LCD at the same display pattern continually. The residual image will happen and it will damage the LCD. Please use screen saver.

REV	REVISION RECORD	DATE NAME
0	NEW RELEASE	11-24-17 SNOW

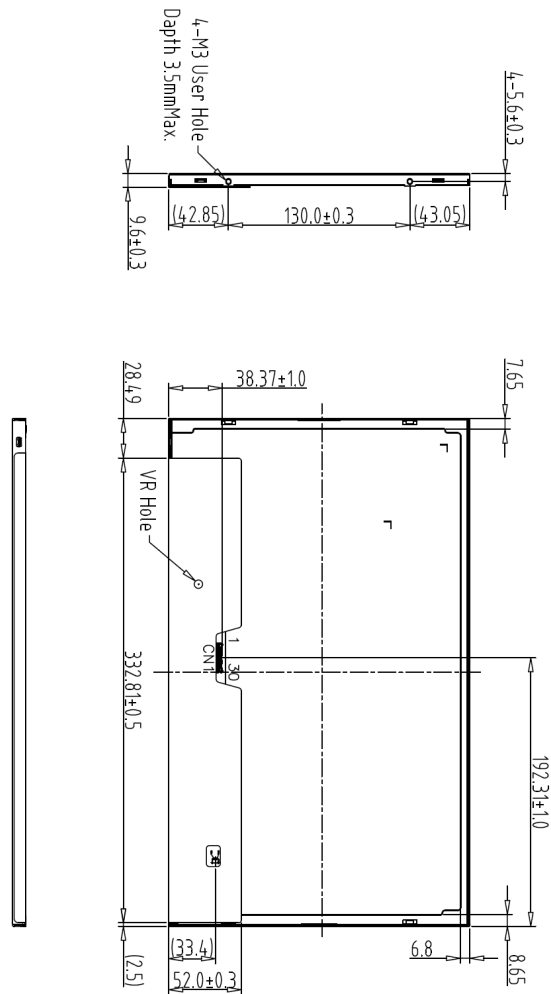

CNT1

1	NC	16	H_GND
2	H_GND	17	HPD
3	LANE1_N	18	BL_GND
4	LANE1_P	19	BL_GND
5	H_GND	20	BL_GND
6	LANE0_N	21	BL_GND
7	LANE0_P	22	BL_ENABLE
8	H_GND	23	BL_PWM
9	AUX_CH_P	24	NC
10	AUX_CH_N	25	NC
11	H_GND	26	BL_POWER
12	LCD_VCC	27	BL_POWER
13	LCD_VCC	28	BL_POWER
14	LCD_Sdft_Test	29	BL_POWER
15	H_GND	30	NC

Note:

1. Unless Indicated, Tolerance "±0.5"
2. UV Glue For OLB Protection
3. LCD 1920x1080 (R:G:B) TFT LCD => 15.6" TFT LCD
4. CNT1:Connector STM MSAK2402SP30 (P0.5x30pin) or Equivalent.

Back view

1	2	7	TOLERANCE GRADE(±)	A	B	DIM.	MM	DWN.	SNOW	DATE	DATE	TITLE
						IR NO.		CHEK.		DATE		 晶采光电科技 AMPIRE 19201080F (15.6") IPS Dwg. No. *170173MA SHEET 1 OF 1
3	8	9				PARTS NO.	LCM-1	APPD.		DATE		
4	10	11				19201080F						
5	11	12										
6												