



晶采光電科技股份有限公司  
AMPIRE CO., LTD.

## SPECIFICATIONS FOR LCD MODULE

<b>CUSTOMER</b>	
<b>CUSTOMER PART NO.</b>	
<b>AMPIRE PART NO.</b>	AM-12801024A1TMQW-30H
<b>APPROVED BY</b>	
<b>DATE</b>	

Approved For Specifications

Approved For Specifications & Sample

**AMPIRE CO., LTD.**

**Building A., 4F., No.116, Sec. 1, Sintai 5th Rd., Xizhi Dist,  
New Taipei City 221, Taiwan (R.O.C.)**

**新北市汐止區新台五路一段 116 號 4 樓(東方科學園區 A 棟)**

**TEL:886-2-26967269 , FAX:886-2-26967196 or 26967270**

APPROVED BY	CHECKED BY	ORGANIZED BY

## RECORD OF REVISION

Revision Date	Page	Contents	Editor
2015/11/06	-	New Release	Simon
2016/07/05	22	Modify Drawing	Simon

## 1. Features

The TFT is 17.0" color TFT-LCD (Thin Film Transistor Liquid Crystal Display) module composed of LCD panel, driver ICs, control circuit and backlight. By applying 8 bit digital data(6Bit+HFRC),1280×RGBX3 X1024, 16.7M-color images are displayed on the 17.0" diagonal screen..

## 2. PHYSICAL SPECIFICATIONS

Item	Specifications	Remark
LCD size	17.0 inch(Diagonal)	
Number of Pixels	1280(H) × 1024(V)	
Display mode	Normally white, TN	
Number of Colors	16.7M (6Bit+HFRC)	
Dot pitch	0.264(W) × 0.264(H)	
Active area	337.92(W) × 270.336(H)	
Module size	358.5 × 296.5 × 9.1 (typ)	
Surface treatment	Anti-Glare, 3H	
Viewing Angle	160 /140(Typ.)	
Backlight	White LED	
Color arrangement	RGB vertical strip	

### 3. ABSOLUTE MAXIMUM RATINGS

ITEM	SYMBOL	VALUES		UNIT	REMARK
		MIN	MAX		
Power Voltage	$V_{DD}$	-0.3	7.0	V	VSS=0V, TA=25°C
	$V_{LED}$	-0.3	15	V	
Operation Temperature	$T_{op}$	-20	70	°C	
Storage Temperature	$T_{st}$	-30	80	°C	

Note 1: The absolute maximum rating values of this product are not allowed to be exceeded at any times.

Should a module be used with any of the absolute maximum ratings exceeded, the characteristics of the module may not be recovered, or in an extreme case, the module may be permanently destroyed.

## 4. ELECTRICAL CHARACTERISTICS

### 4-1 Typical Operation Conditions

ITEM		SYMBOL	MIN	TYP	MAX	UNIT	NOTE
LCD Power Voltage		VCC	4.5	5.0	5.5	V	
LCD Power Current		ICC	-	290	500	mA	*1)
LCD Rush Current		VCC_Irush			3	A	*3)
Logic Input Voltage (LVDS: IN+,IN-)	Common Voltage	VCM	$\frac{ VID }{2}$	-	$2.4 \cdot \frac{ VID }{2}$	V	Logic Input Voltage (LVDS: +,IN-)
	Differential Input Voltage	$ VID $	200	-	600	mV	
	Threshold Voltage (HIGH)	VTH	-	-	100	mV	
	Threshold Voltage (LOW)	VTL	-100	-	-	mV	
Logic Input Voltage	VIH	0.7*DVDD	-	DVDD	V		Logic Input Voltage
	VIL	GND	-	0.3*DVDD	V		
LED Driver Power Voltage		VLED	--	12	--	V	
LED Driver Power Current		$I_{LED}$ (VLED=12V)	--	2.1	--	A	Ta=25°C
ADJ frequency		$f_{PWM}$	100	--	1k	Hz	
ADJ logic level High		VIH	2.0	--	--	V	
ADJ logic level High		VIL	--	--	0.8	V	

**【Note】**

\*1)TYP. specification : Gray-level test Pattern (TYP Freq. @5.0V)

MAX. specification : Black test Pattern (TYP Freq. @5.0V)



Gray-level Pattern

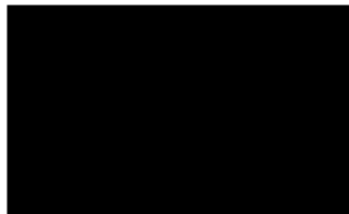

Black Pattern

\*2) LVDS Signal Definite :

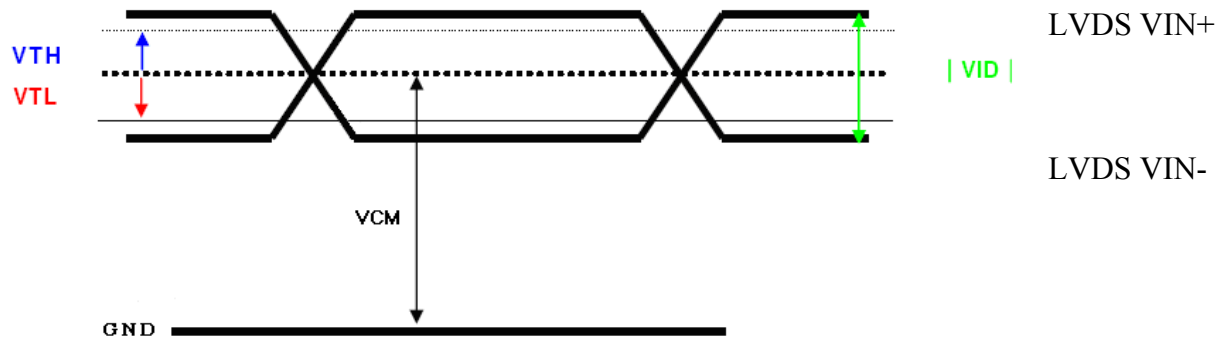

VIN+ : Positive differential DATA & CLK Input

VIN- : Negative differential DATA & CLK Input

\*3) Irush measure condition

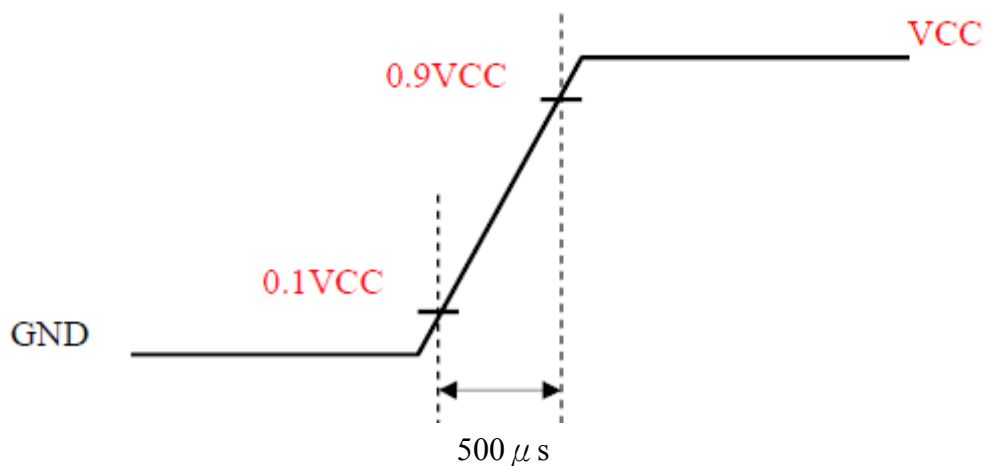
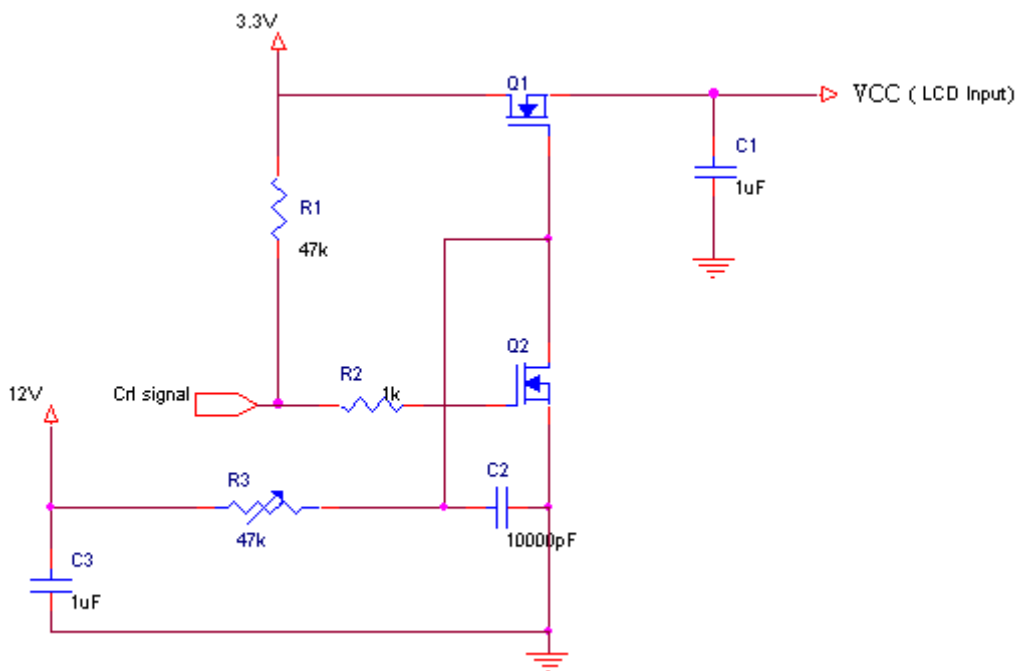

## 4-2 LED Driving Conditions

ITEM	SYMBOL	MIN	TYP	MAX	UNIT	CONDITION
LED Backlight Voltage	$V_{BL}$	--	52	55	V	$I_{BL}=400\text{mA}$
LED Backlight Current	$I_{BL}$	-	400	--	mA	<b><math>T_a=25^\circ\text{C}</math></b>
LED DICE Life Time		--	40K	-	kHr	Note*

Note\* : Brightness to be decreased to 50% of the initial value.

$T_a=25^\circ\text{C}$

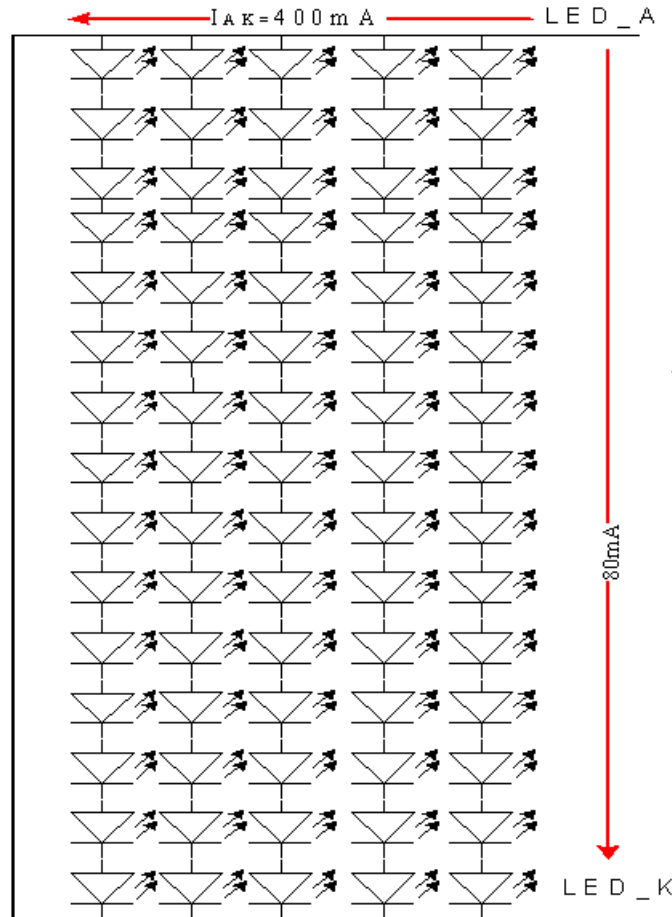

When LCM is operated over  $40^\circ\text{C}$  ambient temperature, the LED should be follow :

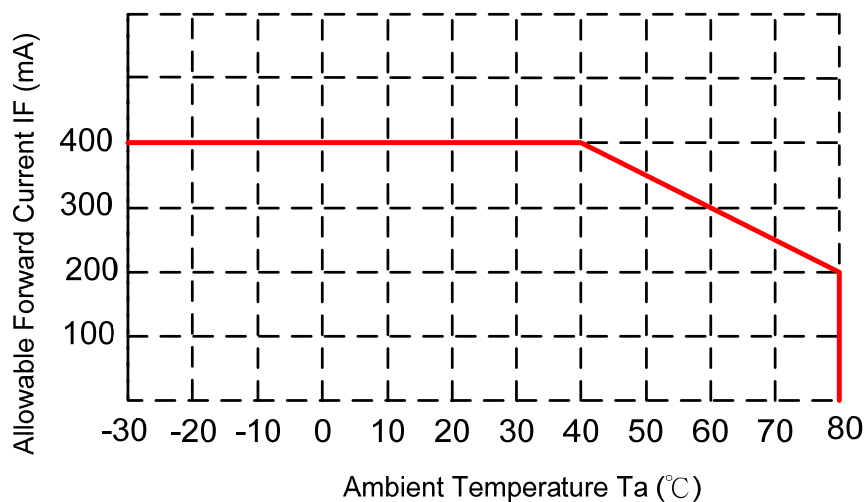

### 4-3 Power Sequence

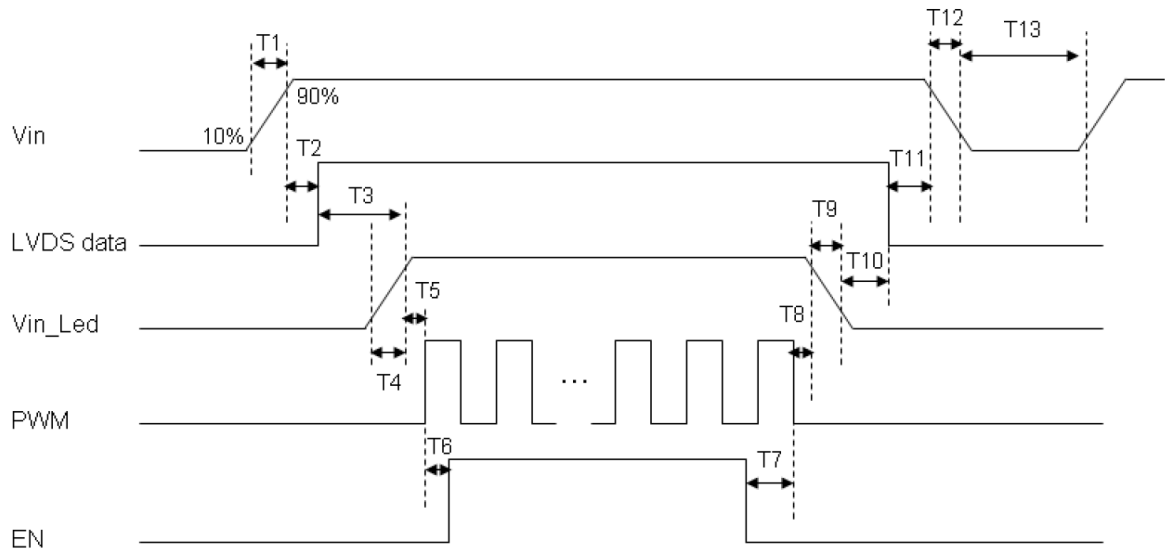

**Table 10 Power Sequencing Requirements**

Parameter	Symbol	Unit	Min	Typ.	Max
VIN Rise Time	T1	ms	0.5	--	10
VIN Good to Signal Valid	T2	ms	30	--	90
Signal Valid to Backlight On	T3	ms	200	--	--
Backlight Power On Time	T4	ms	0.5	--	--
Backlight VDD Good to System PWM On	T5	ms	10	--	--
System PWM ON to Backlight Enable ON	T6	ms	10	--	--
Backlight Enable Off to System PWM Off	T7	ms	0	--	--
System PWM Off to B/L Power Disable	T8	ms	10	--	--
Backlight Power Off Time	T9	ms	--	10	30
Backlight Off to Signal Disable	T10	ms	200	--	--
Signal Disable to Power Down	T11	ms	0	--	50
VIN Fall Time	T12	ms	--	10	30
Power Off	T13	ms	500	--	--



## 5. INTERFACE PIN CONNECTION

### 5.1 LCD INTERFACE

Used connector: 093G30-B2001A-M4(STARCONN) or equivalent

PIN NO.	SYMOBL	FUNCTION
1	RXO0-	minus signal of odd channel 0(LVDS)
2	RXO0+	plus signal of odd channel 0(LVDS)
3	RXO1-	minus signal of odd channel 1(LVDS)
4	RXO1+	plus signal of odd channel 1(LVDS)
5	RXO2-	minus signal of odd channel 2(LVDS)
6	RXO2+	plus signal of odd channel 2(LVDS)
7	GND	ground
8	RXOC-	minus signal of odd clock channel (LVDS)
9	RXOC+	plus signal of odd clock channel (LVDS)
10	RXO3-	minus signal of odd channel 3(LVDS)
11	RXO3+	plus signal of odd channel 3(LVDS)
12	RXE0-	minus signal of even channel 0(LVDS)
13	RXE0+	plus signal of even channel 0(LVDS)
14	GND	ground
15	RXE1-	minus signal of even channel 1(LVDS)
16	RXE1+	plus signal of even channel 1(LVDS)
17	GND	ground
18	RXE2-	minus signal of even channel 2(LVDS)
19	RXE2+	plus signal of even channel 2(LVDS)
20	RXEC-	minus signal of even clock channel (LVDS)
21	RXEC+	plus signal of even clock channel (LVDS)
22	RXE3-	minus signal of even channel 3(LVDS)
23	RXE3+	plus signal of even channel 3(LVDS)
24	GND	ground
25	GND	ground
26	GND	ground
27	GND	ground
28	VCC	Power supply input voltage(5.0 V)
29	VCC	Power supply input voltage(5.0 V)
30	VCC	Power supply input voltage(5.0 V)

1) Please keep the NC Pin and don't connect it to GND or other signals.

2) GND Pin must connect to the ground, don't let it be a vacant pin.

### 5.2 LED DRIVER BOARD INTERFACE

CN2: JST SM04B-SRSS-TB (LF) (SN)

Pin No.	Symbol	I/O	Description	Note
1	VLED	P	Voltage for LED circuit	
2	LED_EN	I	LED BLU ON/OFF. High level: ON; Low level: OFF.	
3	GND	I	Power ground	
4	ADJ	P	Adjust the LED brightness by PWM	

## 6. INTERFACE TIMING

### (1) Timing Specifications

		ITEM	SYMBOL	MIN	TYP	MAX	UNIT
LCD Timing	DCLK	Frequency	$f_{CLK}$	44	54	67.5	MHz
		Period	$t_{CLK}$	14.81	18.52	22.2	ns
	DATA Enable	Horizontal Active	$t_{HA}$		640		$t_{CLK}$
		Horizontal Blank	$t_{HB}$	140	204	-	$t_{CLK}$
		Horizontal Total Time	$t_H$	780	844	2047	$t_{CLK}$
		Vertical Active Time	$t_{VA}$		1024		tH
		Vertical Blank Time	$t_{VB}$	8	42	126	tH
		Vertical Total Time	$t_V$	1032	1066	1150	tH
DENA	Vertical Frame Rate	Fr	50	60	75	Hz	

### (2) Timing Chart

#### a. Horizontal Timing

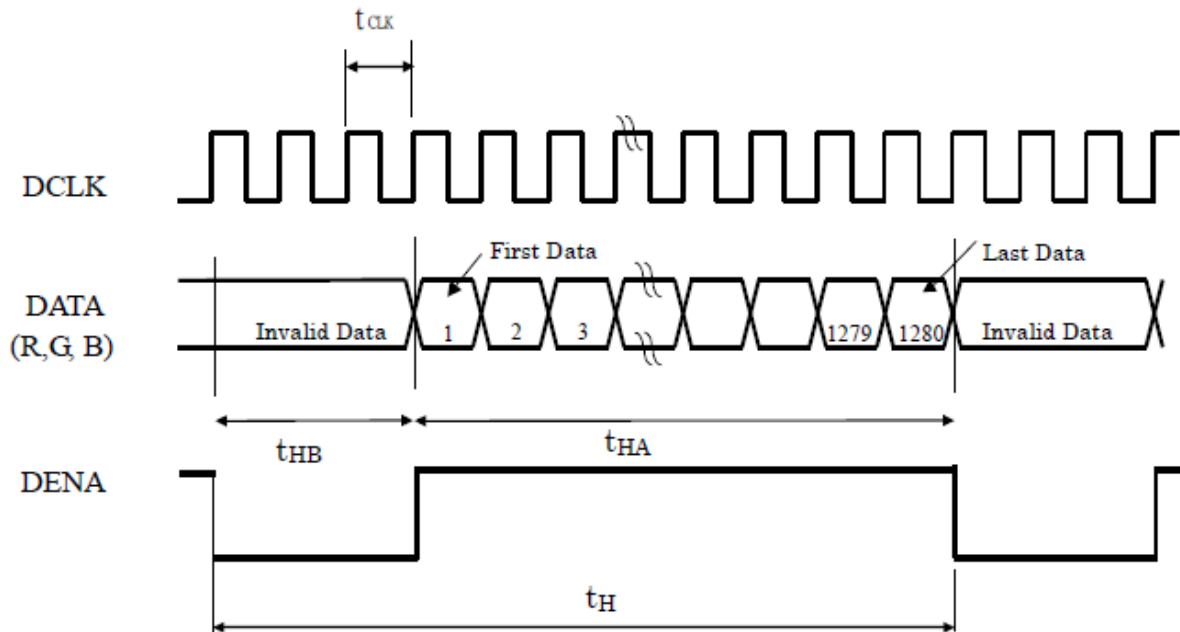

b. Vertical Timing

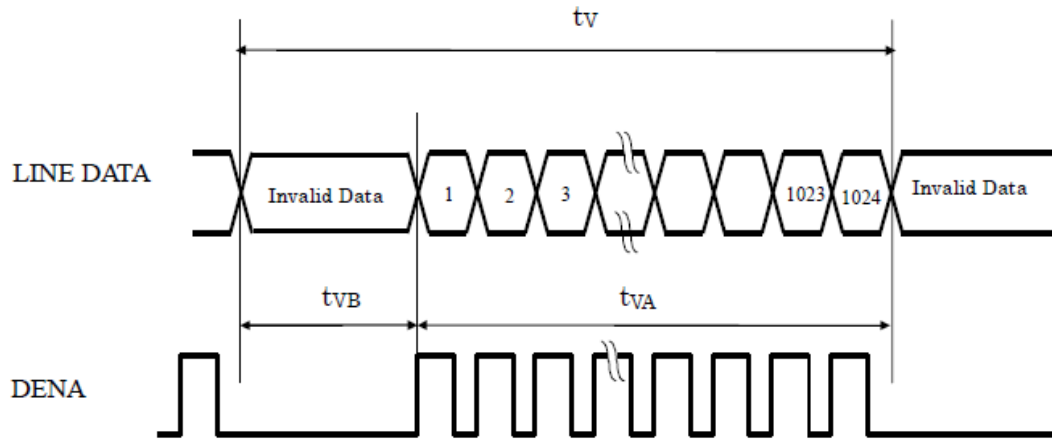

(3) LVDS DATA (VESA) : Timing Chart

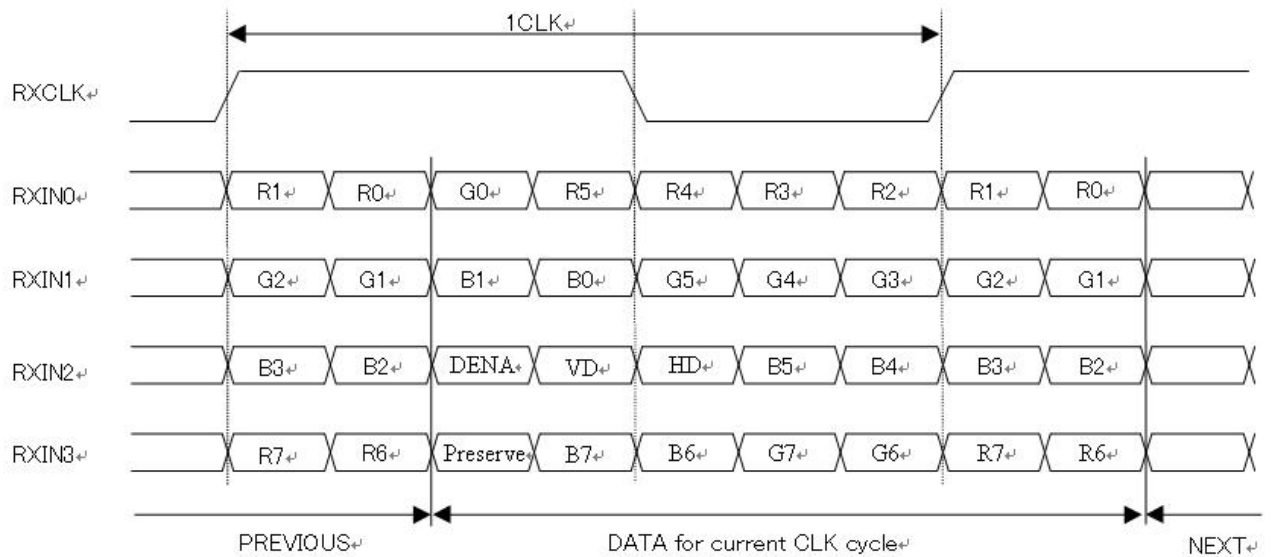

(4) Color Data Assignment

COLOR	INPUT DATA	R DATA								G DATA								B DATA							
		R7 MSB	R6	R5	R4	R3	R2	R1	R0 LSB	G7 MSB	G6	G5	G4	G3	G2	G1	G0 LSB	B7 MSB	B6	B5	B4	B3	B2	B1	B0 LSB
BASIC COLOR	BLACK	0	0	0	0	0	0	0	0	0	0	0	0	0	0	0	0	0	0	0	0	0	0	0	0
	RED(255)	1	1	1	1	1	1	1	1	0	0	0	0	0	0	0	0	0	0	0	0	0	0	0	
	GREEN(255)	0	0	0	0	0	0	0	0	1	1	1	1	1	1	1	0	0	0	0	0	0	0	0	
	BLUE(255)	0	0	0	0	0	0	0	0	0	0	0	0	0	0	0	1	1	1	1	1	1	1	1	
	CYAN	0	0	0	0	0	0	0	0	1	1	1	1	1	1	1	1	1	1	1	1	1	1	1	
	MAGENTA	1	1	1	1	1	1	1	1	0	0	0	0	0	0	0	1	1	1	1	1	1	1	1	
	YELLOW	1	1	1	1	1	1	1	1	1	1	1	1	1	1	1	0	0	0	0	0	0	0	0	
	WHITE	1	1	1	1	1	1	1	1	1	1	1	1	1	1	1	1	1	1	1	1	1	1	1	
RED	RED(0)	0	0	0	0	0	0	0	0	0	0	0	0	0	0	0	0	0	0	0	0	0	0		
	RED(1)	0	0	0	0	0	0	0	1	0	0	0	0	0	0	0	0	0	0	0	0	0	0		
	RED(2)	0	0	0	0	0	0	1	0	0	0	0	0	0	0	0	0	0	0	0	0	0	0		
	RED(254)	1	1	1	1	1	1	1	0	0	0	0	0	0	0	0	0	0	0	0	0	0	0		
	RED(255)	1	1	1	1	1	1	1	1	0	0	0	0	0	0	0	0	0	0	0	0	0	0		
GREEN	GREEN(0)	0	0	0	0	0	0	0	0	0	0	0	0	0	0	0	0	0	0	0	0	0	0		
	GREEN(1)	0	0	0	0	0	0	0	0	0	0	0	0	0	1	0	0	0	0	0	0	0	0		
	GREEN(2)	0	0	0	0	0	0	0	0	0	0	0	0	0	1	0	0	0	0	0	0	0	0		
	GREEN(254)	0	0	0	0	0	0	0	1	1	1	1	1	1	1	0	0	0	0	0	0	0	0		
	GREEN(255)	0	0	0	0	0	0	0	1	1	1	1	1	1	1	1	0	0	0	0	0	0	0		
BLUE	BLUE(0)	0	0	0	0	0	0	0	0	0	0	0	0	0	0	0	0	0	0	0	0	0	0		
	BLUE(1)	0	0	0	0	0	0	0	0	0	0	0	0	0	0	0	0	0	0	0	0	0	1		
	BLUE(2)	0	0	0	0	0	0	0	0	0	0	0	0	0	0	0	0	0	0	0	0	0	1		
	BLUE(254)	0	0	0	0	0	0	0	0	0	0	0	0	0	0	1	1	1	1	1	1	1	0		
	BLUE(255)	0	0	0	0	0	0	0	0	0	0	0	0	0	0	1	1	1	1	1	1	1	1		

[Note]

1) Definition of gray scale:

Color (n): n indicates gray scale level; higher n means brighter level.

2) Data: 1-High, 0-Low.

3) This assignment is applied to both odd and even data.

## 7. BLOCK DIAGRAM

### TFT- LCD Module

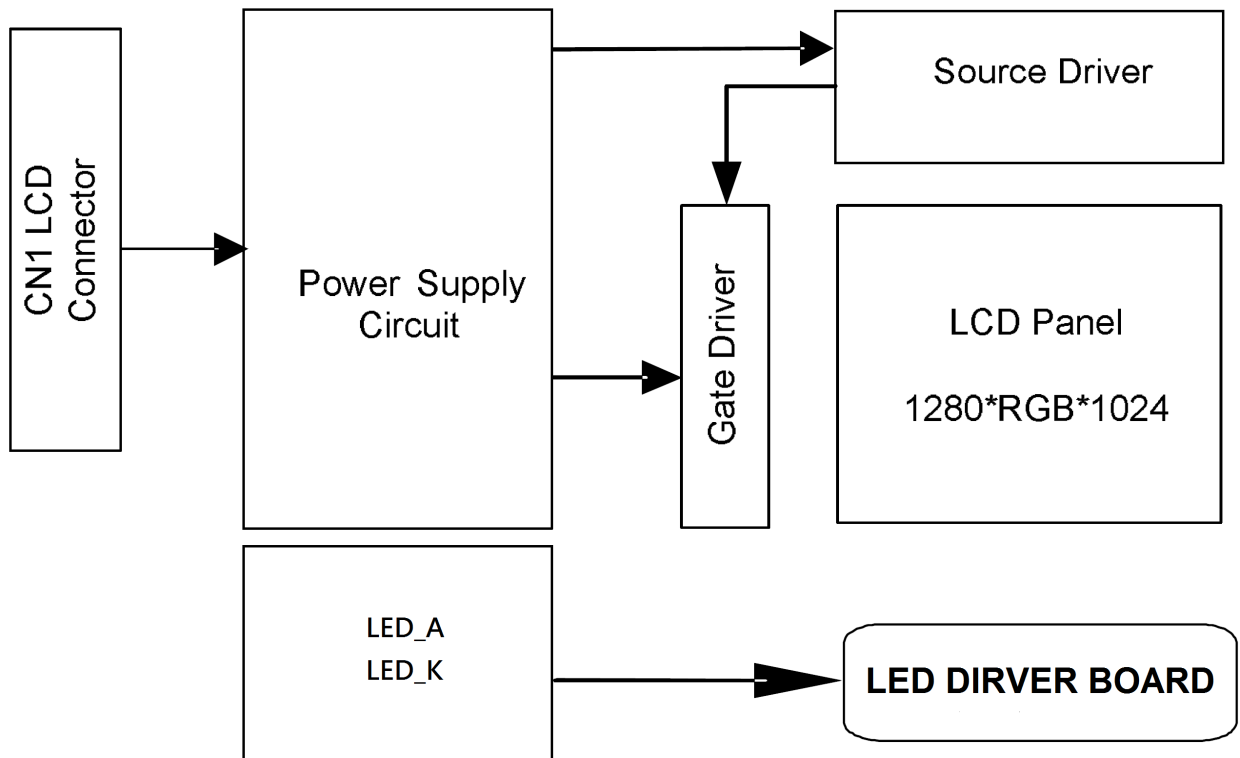

## 8. OPTICAL CHARACTERISTICS

Ta=25°C , VCC=3.3

ITEM		SYMBOL	CONDITION	min	typ	max	UNIT	REMARK
Contrast Ratio		CR	$\theta = \psi = 0^\circ$	--	700	--	--	*1) 2)
Luminance(CEN)		L	$\theta = \psi = 0^\circ$	800	1000	--	cd/m <sup>2</sup>	*1) 3)
9P Uniformity		$\Delta L$	$\theta = \psi = 0^\circ$	75	80	--	%	*1) 3)
Response Time		Tr	$\theta = \psi = 0^\circ$	--	10	15	ms	*5)
		Tf	$\theta = \psi = 0^\circ$	--	15	25		
Crosstalk		CT	$\theta = \psi = 0^\circ$	--	--	--	%	*6)
Viewing Angle	Horizontal	$\psi$	$CR \geq 10$	-70~70	-80~80	--	Deg.	*4)
	Vertical	$\theta$		-60~60	-70~70	--		
Color Coordinates		White	$\theta = \psi = 0^\circ$	(0.263) (0.279)	(0.313) (0.329)	(0.363) (0.379)		*3)
		Red		TBD	TBD	TBD		
		Green		TBD	TBD	TBD		
		Blue		TBD	TBD	TBD		
Gamut		CG	$\theta = \psi = 0^\circ$	67	72	--	--	--
Gamma		$\gamma$	VESA	2	2.2	2.4	--	*7)

[Note]

Definition of these measurement items is as follows:

### 1) Setup of Measurement Equipment

The LCD module should be turn-on to a stable luminance level to be reached. The measurement should be executed after lighting Backlight for 20 minutes and in a dark room.

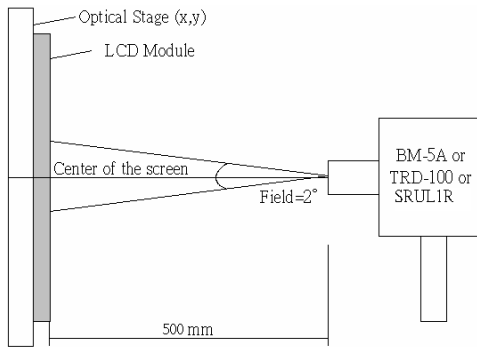

2).Definition of Contrast Ratio:

CR=ON (White) Luminance/OFF (Black) Luminance

3).Definition of Luminance and Luminance uniformity:

Center Luminance, &Color coordinate: measuring the luminance of the point no. 5

Average Luminance: measuring average luminance of points no.1-no.9

Uniformity:  $\Delta L = [L (\text{Min})/L (\text{Max})] \times 100 \%$

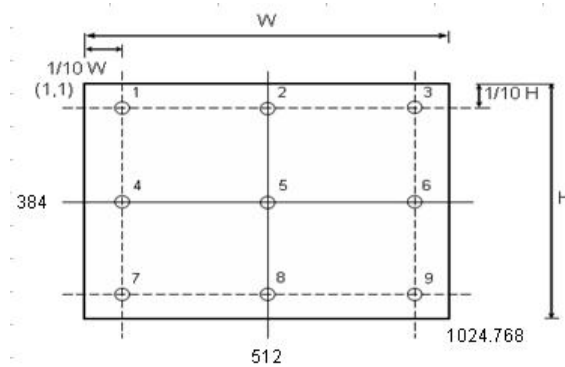

4).Definition of Viewing Angle ( $\theta$  ,  $\psi$  ):

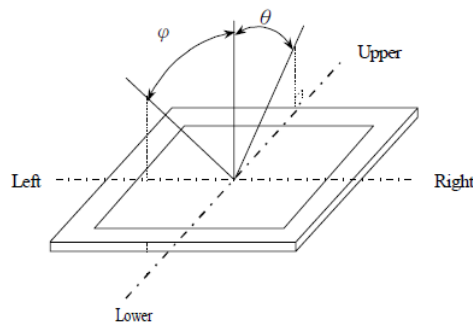

5) Definition of Response Time:

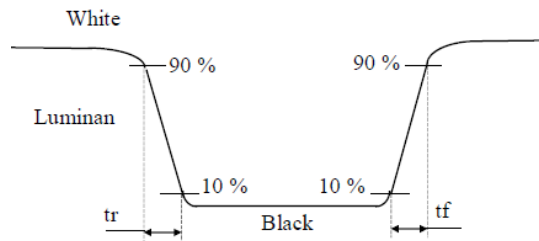

6) Definition of crosstalk:

$$CT = |Y_B - Y_A| / Y_A \times 100 (\%)$$

$Y_A$ : The luminance of measured position at pattern A

$Y_B$ : The luminance of measured position at pattern B with Gray level 0

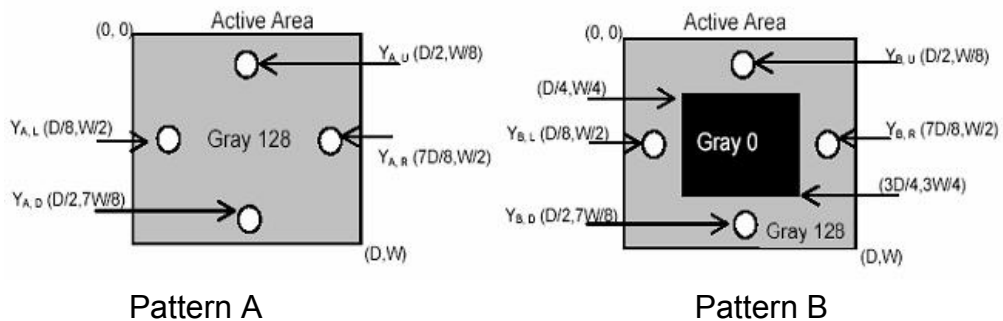

7) Definition of Gamma ( $\gamma$  ), follow VESA standard sampling every 16 gray level

(0,16,32,.....224,240,255)

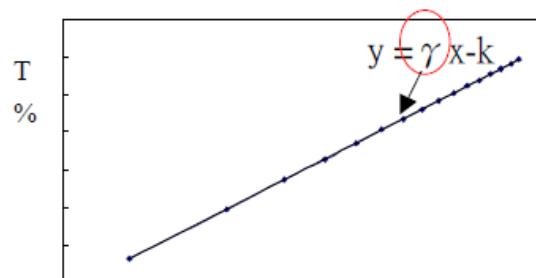

Gray level (LOG)



## 9. RELIABILITY TEST CONDITIONS

### (1) Temperature and Humidity

TEST ITEMS	CONDITIONS	REMARK
High Temperature High Humidity Storage	60°C; 90%RH; 240hrs (No condensation)	
High Temperature Operation	70°C; 240hrs	
High Temperature Storage	80°C; 240hrs	
Low Temperature Operation	-20°C; 240hrs	
Low Temperature Storage	-30°C; 240hrs	
Thermal Shock	Between -30°C(1hr) ~ 80°C(1hr); 100 Cycles	
Image Sticking	25 °C ± 2 °C ; 4hrs	Note 1
MTBF	Life assurance 20,000hrs	

[Note]

Definition of these measurement items is as follows:

#### 1) Image Sticking :

Condition of image sticking test: 25°C

Operation with test pattern sustained for 4hrs, then change to gray pattern immediately.

After 5 min, the Mura must be disappeared completely.

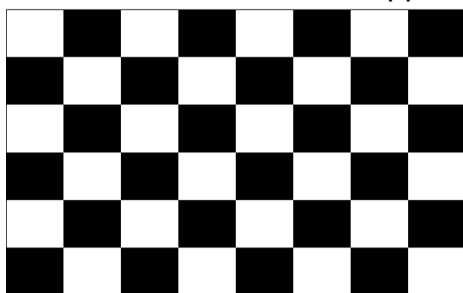

(a) Test Pattern(Chess Board Pattern)



(b) judgment Pattern(Mid-Gray Pattern)

## **10. GENERAL PRECAUTION**

### **10.1 Use Restriction**

This product is not authorized for use in life supporting systems, aircraft navigation control systems, military systems and any other application where performance failure could be life-threatening or otherwise catastrophic.

### **10.2 Disassembling or Modification**

Do not disassemble or modify the module. It may damage sensitive parts inside LCD module, and may cause scratches or dust on the display. AMPIRE does not warrant the module, if customers disassemble or modify the module.

### **10.3 Breakage of LCD Panel**

- (1) If LCD panel is broken and liquid crystal spills out, do not ingest or inhale liquid crystal, and do not contact liquid crystal with skin.
- (2) If liquid crystal contacts mouth or eyes, rinse out with water immediately.
- (3) If liquid crystal contacts skin or cloths, wash it off immediately with alcohol and rinse thoroughly with water.
- (4) Handle carefully with chips of glass that may cause injury, when the glass is broken.

### **10.4 Electric Shock**

- (1) Disconnect power supply before handling LCD module.
- (2) Do not pull or fold the LED cable.
- (3) Do not touch the parts inside LCD modules and the fluorescent LED's connector or cables in order to prevent electric shock.

### **10.5 Absolute Maximum Ratings and Power Protection Circuit**

- (1) Do not exceed the absolute maximum rating values, such as the supply voltage variation, input voltage variation, variation in parts' parameters, environmental temperature, etc., otherwise LCD module may be damaged.
- (2) Please do not leave LCD module in the environment of high humidity and high temperature for a long time.
- (3) It's recommended to employ protection circuit for power supply.

## **10.6 Operation**

- (1) Do not touch, push or rub the polarizer with anything harder than HB pencil lead.
- (2) Use fingerstalls of soft gloves in order to keep clean display quality, when persons handle the LCD module for incoming inspection or assembly.
- (3) When the surface is dusty, please wipe gently with absorbent cotton or other soft material.
- (4) Wipe off saliva or water drops as soon as possible. If saliva or water drops contact with polarizer for a long time, they may cause deformation or color fading.
- (5) When cleaning the adhesives, please use absorbent cotton wetted with a little petroleum benzene or other adequate solvent.

## **10.7 Mechanism**

Please mount LCD module by using mounting holes arranged in four corners tightly.

## **10.8 Static Electricity**

- (1) Protection film must remove very slowly from the surface of LCD module to prevent from electrostatic occurrence.
- (2) Because LCD modules use CMOS-IC on circuit board and TFT-LCD panel, it is very weak to electrostatic discharge. Please be careful with electrostatic discharge. Persons who handle the module should be grounded through adequate methods.

## **10.9 Strong Light Exposure**

The module shall not be exposed under strong light such as direct sunlight. Otherwise, display characteristics may be changed.

## **10.10 Disposal**

When disposing LCD module, obey the local environmental regulations.

## **10.11 Others**

Do not keep the LCD at the same display pattern continually. The residual image will happen and it will damage the LCD. Please use screen saver.



REV	REVISION RECORD	DATE NAME
0	NEW RELEASE	D-07-19SNOW
1	Rename TF12801024-01-0 to 12801024A1-30	D-30-19SNOW

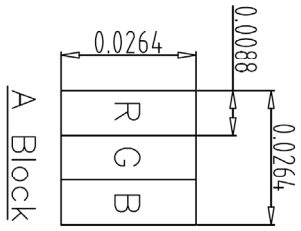

CN1	
1	RX00- 16 RXE1+
2	RX00+ 17 GND
3	RX01- 18 RXE2-
4	RX01+ 19 RXE2+
5	RX02- 20 RXEC-
6	RX02+ 21 RXEC+
7	GND 22 RXE3-
8	RX0C- 23 RXE3+
9	RX0C+ 24 GND
10	RX03- 25 GND
11	RX03+ 26 GND
12	RXE0- 27 GND
13	RXE0+ 28 VCC
14	GND 29 VCC
15	RXE1- 30 VCC

CN3	
1	A1
2	A2
3	A3
4	K1
5	K2
6	K3

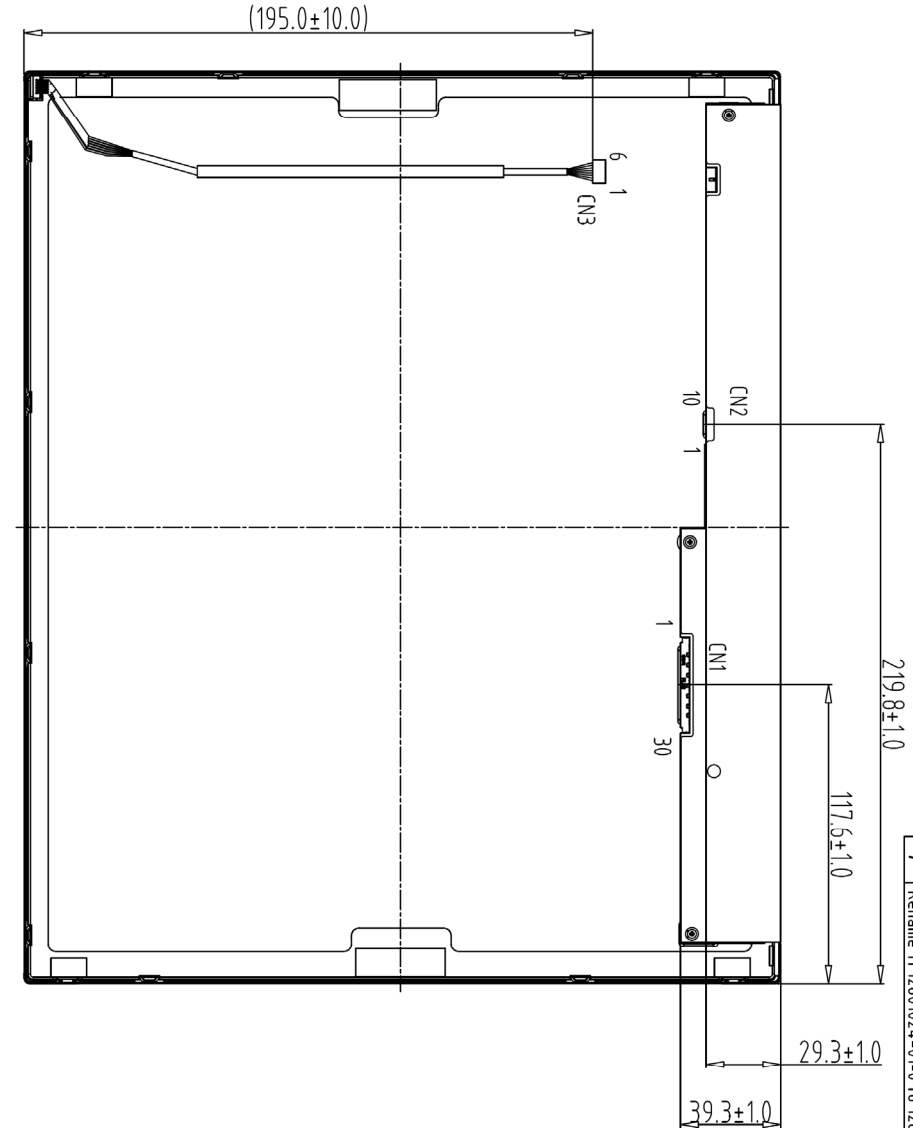

Note:

1. Unless indicated, Tolerance "±0.5"
2. CN1:Connector 093G30-B2001A-M4 or Equivalent.
3. CN2:Connector 7905Y10-000000-M1-R or Equivalent.
4. CN3:P1.0 6pin, Mating Connector: Cvilux C11406M1HRL-NH or Equivalent

Back view

1	12801024A	7	TOLERANCE GRADE(F)	A	B	DIM.	DWN.	DATE	TITLE
2	TF12801024-01-0	8				MM	SNOW	07-02-15	12801024A1-30
3		9				IE NO.	CHK.	DATE	(17.0")
4		10				PARTS NO.	APPD.	DATE	DWG. NO.
5		11				12801024A1-30			*150717MA
6		12							SHEET 1 OF 1

**AMPIRE** 晶采光電科技

REV	REVISION RECORD	DATE	NAME
0	NEW RELEASE	09-25-16	SNOW
1	Rename TF12801024-02-0 to 12801024A	10-08-16	SNOW
2	Modify pin 4 to pin 1	01-11-18	SNOW

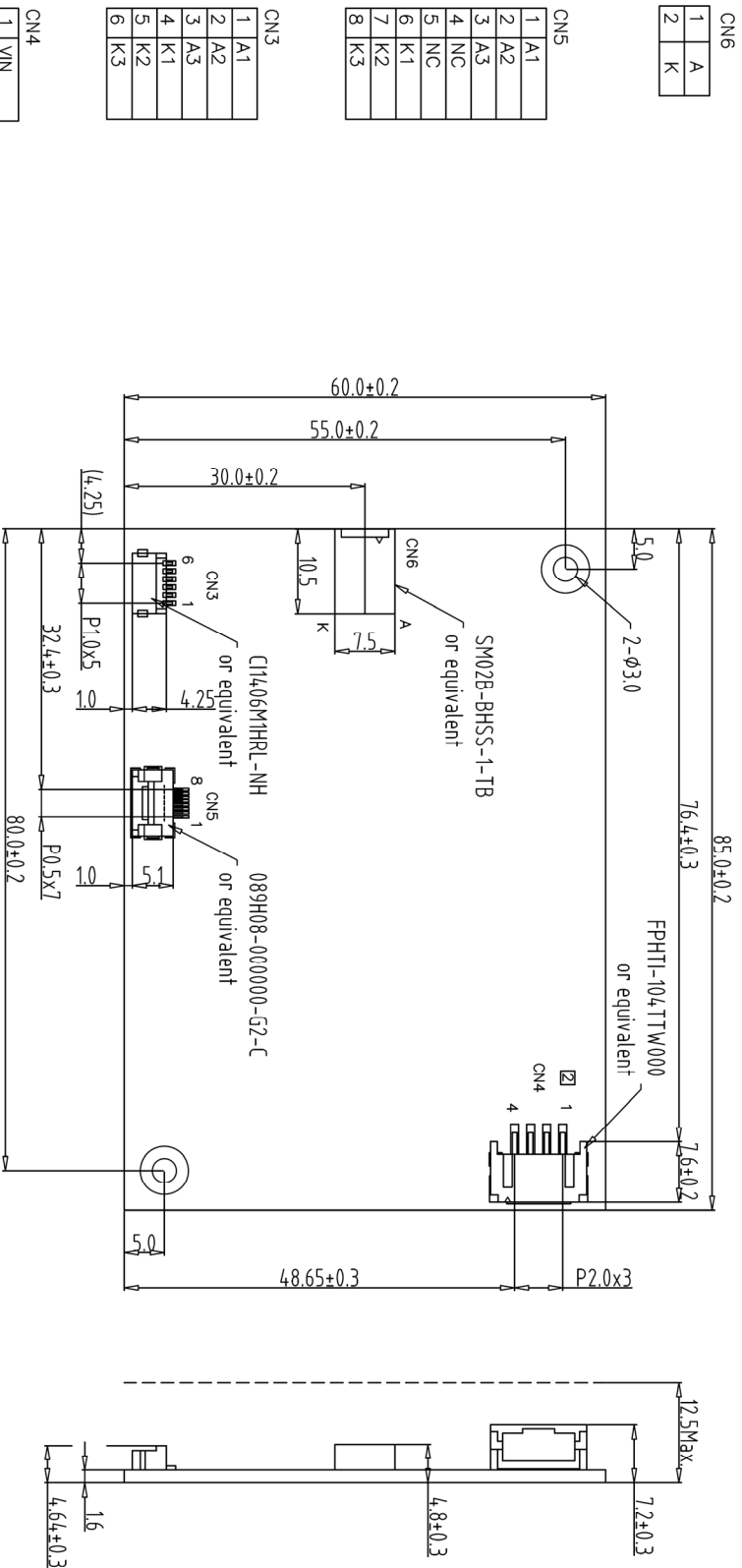

Note:  
 1. Unless indicated, Tolerance Grade "±0.3" is adopted.  
 2. UV Glue For OLB Protection.

1	TF12801024-02-0	7		TOLERANCE GRADE(F)	A	B	DIM.	MM	DWN.	SNOW	DATE	09-25-15	TITLE	AMPiRE 晶采光電科技
2		8					IE NO.	2812801001	CHK.		DATE		12801024A	(17.0" & 19.0")
3		9					PARTS NO. LCM	12801024A	APPD.		DATE		DWG. NO.	*150992MB
4		10											SHEET	1 OF 1
5		11												
6		12												