



晶采光電科技股份有限公司
AMPIRE CO., LTD.

SPECIFICATIONS FOR LCD MODULE

CUSTOMER	
CUSTOMER PART NO.	
AMPIRE PART NO.	AM-1024768TTMQW-00H
APPROVED BY	
DATE	

Approved For Specifications

Approved For Specifications & Sample

AMPIRE CO., LTD.

**4F., No.116, Sec. 1, Xintai 5th Rd., Xizhi Dist., New Taipei
City221, Taiwan (R.O.C.)**

新北市汐止區新台五路一段 116 號 4 樓(東方科學園區 A 棟)

TEL:886-2-26967269 , FAX:886-2-26967196 or 26967270

APPROVED BY	CHECKED BY	ORGANIZED BY
		

RECORD OF REVISION

Revision Date	Page	Contents	Editor
2014/05/05	--	New Release	Rober

1.0 General Descriptions

1.1 Introduction

The LCM is a color active matrix thin film transistor (TFT) liquid crystal display (LCD) that uses amorphous silicon TFT as a switching device. It is composed of a TFT LCD panel, a backlight system, column driver and row driver circuit. This TFT LCD has a 10.4-inch diagonally measured active display area with resolution (1024 horizontal by 768 vertical pixels array).

1.2 Features

- 10.4" TFT LCD Panel
- LED Backlight System
- Supported 1024x768 pixels resolution
- Compatible with RoHS Standard

1.3 Product Summary

Items	Specifications	Unit
Screen Diagonal	10.4	Inch
Active Area	211.2(H) x 158.4(V)	mm
Pixel Format	1024(RGB) x768	-
Pixel Pitch	0.24(H) x 0.24(V)	mm
Pixel Arrangement	R.G.B. Vertical Stripe	-
Display Mode	Normally White	-
White Luminance	350(Typ)	cd /m2
Contrast Ratio	900 : 1 (Typ)	-
Response Time	16(TYP)	msec
Input Voltage	3.3	V
Weight	290(Max)	g
Outline Dimensions	236.0(H) x 176.9(V) x5.7(D) Typ.	mm
Electrical Interface (Logic)	LVDS	-
Support Color	262 K/16.7M	-
Surface Treatment	Anti-glare	-

1.4 Functional Block Diagram

Shows the functional block diagram of the LCD module.

Figure 1 Block Diagram

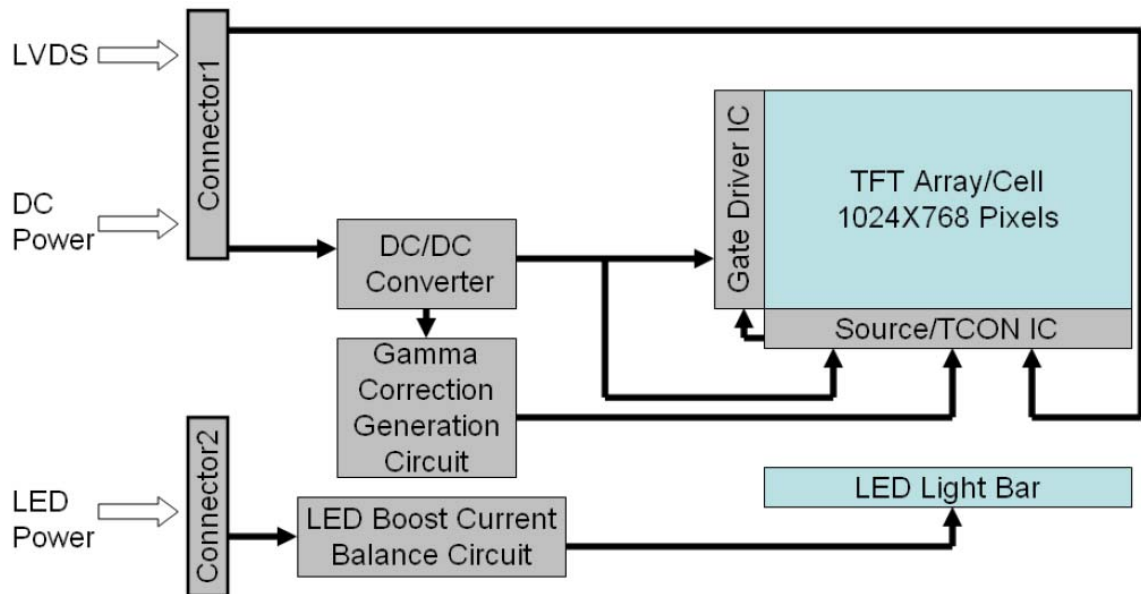

2.0 Absolute Maximum Ratings

Table 1 Absolute Ratings of Environment

Item	Symbol	Min	Max	Unit	Conditions
Supply Voltage	VDD	-0.5	5	V	-
Operating Temperature	TOP	-20	70	°C	Note
Operating Humidity	HOP	10	85	%RH	Note
Storage Temperature	TST	-30	80	°C	Note
Storage Humidity	HST	10	95	%RH	Note

Note (1): Humidity: 85%RH Max. ($T \leq 40^\circ\text{C}$) Note static electricity.

Maximum wet bulb temperature at 39°C or less. ($T > 40^\circ\text{C}$) No condensation.

Note (2): There is a possibility of causing deterioration in the irregularity and others of the screen and the display fineness though the liquid crystal module doesn't arrive at destruction when using it at $80 \sim 85^\circ\text{C}$ or -20°C .

Note (3): There is a possibility of causing the fineness deterioration by the prolonged use in the (high temperature) humidity environment (60% or more).

Note (4): In the operating temperature item, the low temperature side is the ambient temperature regulations. The high temperature side is the panel surface temperature regulations.

Note (5): Storage Range&Operating Range Picture:

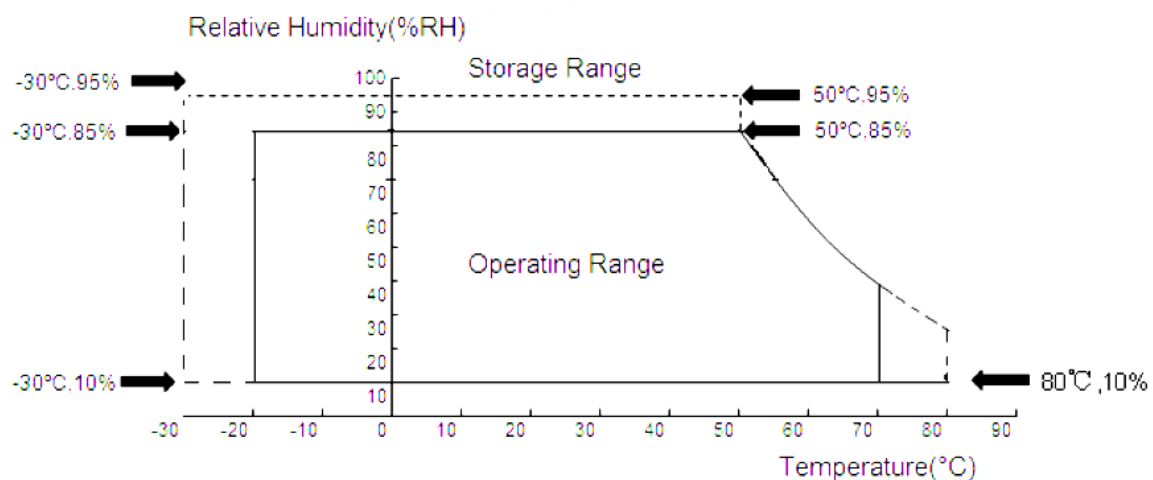

3.0 Pixel Format Image

Figure 2 shows the relationship of the input signals and LCD pixel format image.

Figure 2 Pixel Format

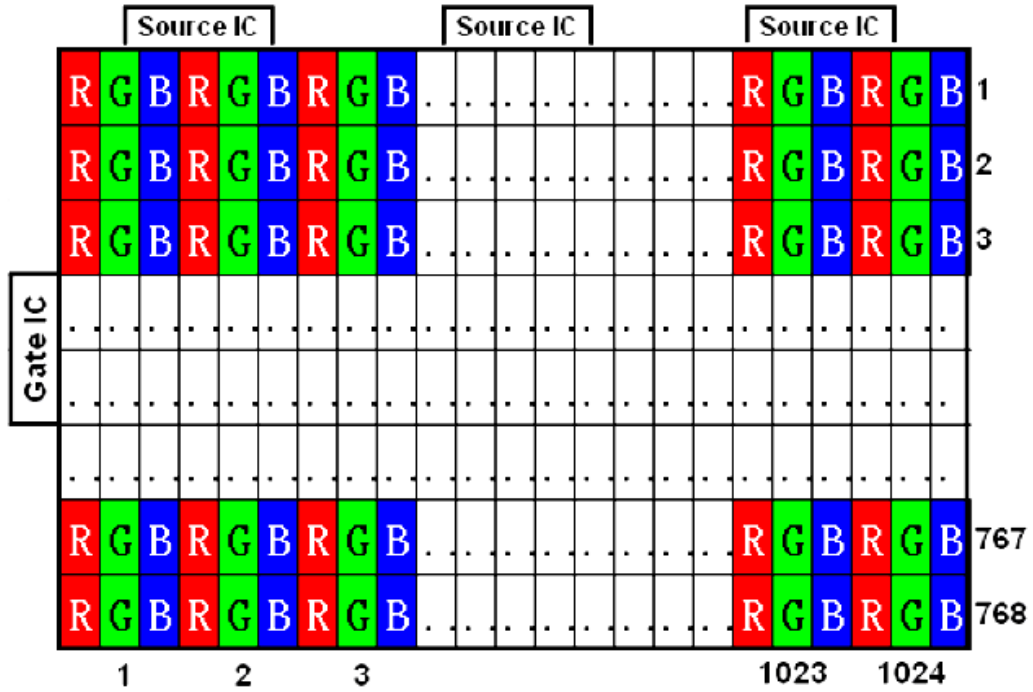

4.0 Optical Characteristics

The optical characteristics are measured under stable conditions as following notes

Table 2 Optical Characteristics

Item	Conditions		Min.	Typ.	Max.	Unit	Note
Viewing Angle (CR>10)	Horizontal	θ_L	70	75	-	degree	(1),(2),(3)
		θ_R	70	75	-		
	Vertical	θ_T	70	75	-		
		θ_B	70	75	-		
Contrast Ratio	Center		720	900	-	-	(1),(2),(4)
Response Time	Rising + Falling		-	16	TBD	ms	(1),(2),(5)
Color Chromaticity	Red	x	Typ. -0.03	TBD	Typ. +0.03	-	(1),(2)
	Red	y		TBD		-	
	Green	x		TBD		-	
	Green	y		TBD		-	
	Blue	x		TBD		-	
	Blue	y		TBD		-	
	White	x	0.26	0.31	0.36	-	
	White	y	0.28	0.33	0.38	-	
White Luminance	Center		300	350	-	cd/m ²	(1),(2),(6)
Luminance Uniformity	9Points		75	80	-	%	(1),(2),(6)

Note (1) Measurement Setup:

The LCD module should be stabilized at given temperature(25 °C) for 15 minutes to Avoid abrupt temperature change during measuring. In order to stabilize the luminance, the measurement should be executed after lighting backlight for 15 minutes in a windless room.

Figure 3 Measurement Setup

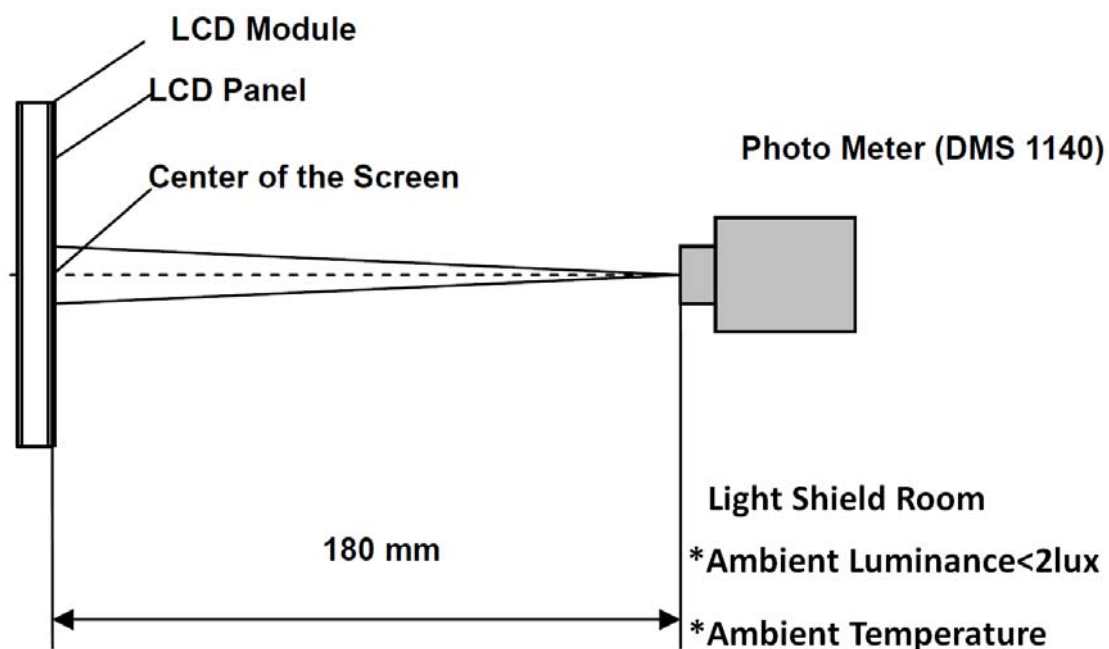

Note (2) The LED input parameter setting as:

VLED: 12V;

PWM_LED: Duty 100 %

Note (3) Definition of Viewing Angle

Figure 4 Definition of Viewing Angle

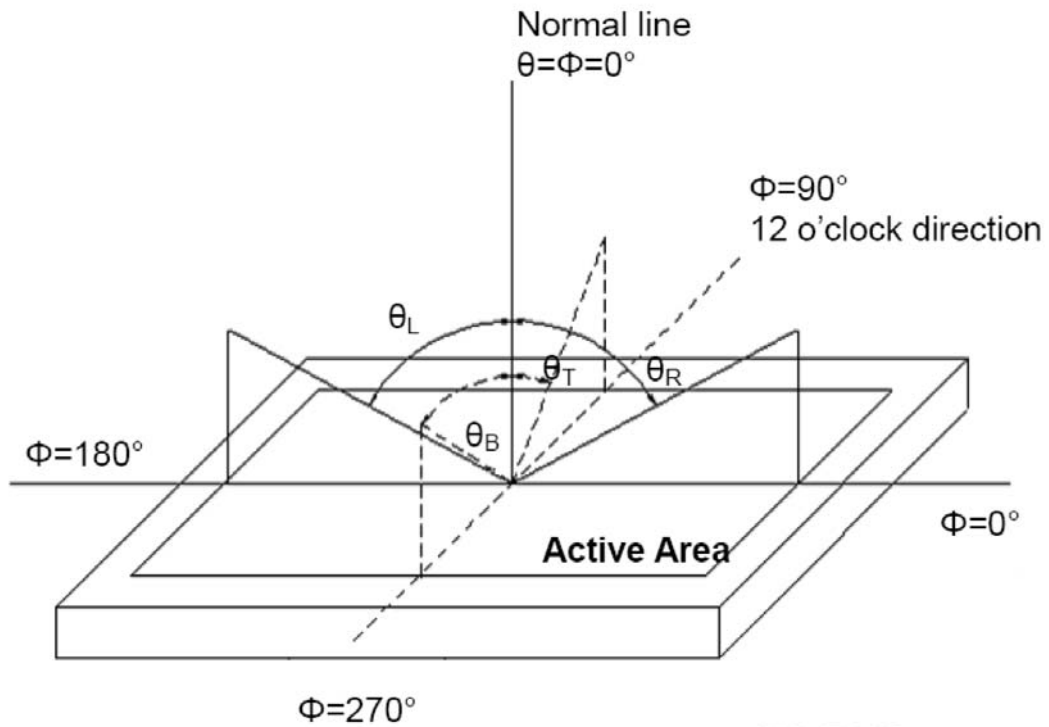

Note (4) Definition Of Contrast Ratio (CR)

The contrast ratio can be calculated by the following expression

$$\text{Contrast Ratio (CR)} = L_{255} / L_0$$

L255: Luminance of gray level 255, L0: Luminance of gray level 0

Note (5) Definition Of Response Time (TR, TF)

Figure 5 Definition of Response Time

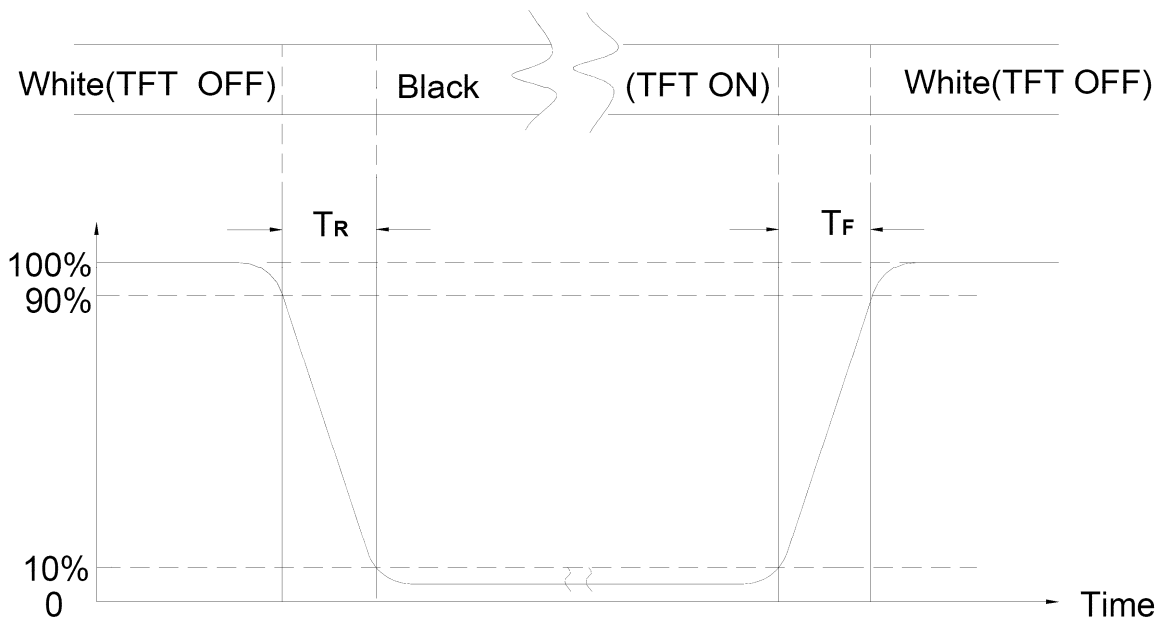

Note (6) Definition Of Brightness Luminance

$$\text{Luminance uniformity} = \frac{(\text{Min Luminance of 5 points})}{(\text{Max Luminance of 5 points})} \times 100\%$$

Figure 6 Measurement Locations

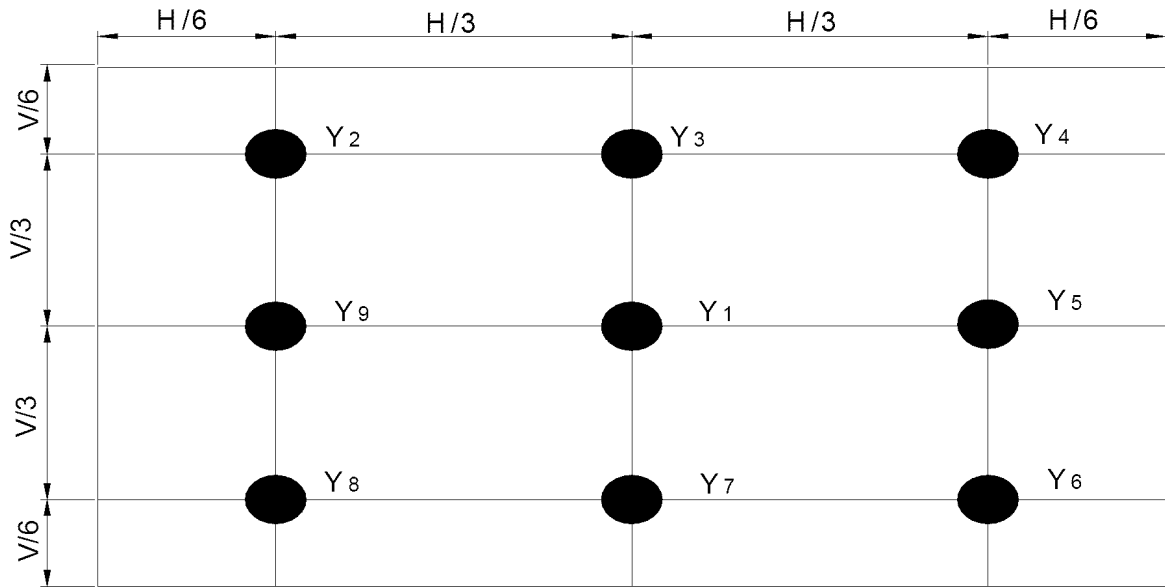

5.0 Backlight Characteristics

5.1 Parameter Guideline Of LED Backlight

Table 3 Parameter Guideline for LED Backlight

Item	Symbol	Min.	Typ.	Max.	Units	Note
LED Input Voltage	V_{LED}	10.8	12	12.6	V	(2),(3)
LED Power Consumption	P_{LED}	-	-	(2.88)	W	(2),(3)
LED Forward Voltage	V_F	2.8	3.2	3.6	V	(2)
LED Forward Current	I_F	-	20	30	mA	
PWM Signal Voltage	V_{PWM_EN}	High	4.5	5	V	
		Low	0	-		
LED Enable Voltage	V_{LED_EN}	High	2.0	5	V	
		Low	0	-		
Input PWM Frequency	FPWM	100	-	1K	Hz	
LED Life Time	LT	30,000	-	-	Hours	(1)(2)
Duty Ratio	PWM	5	-	100	%	(2)

Note A: The LED life time define as the estimated time to 50% degradation of initial luminous.

Note B: A higher LED power supply voltage will result in better power efficiency.
Keep the VLED between 12V and 12.6V is strongly recommended.

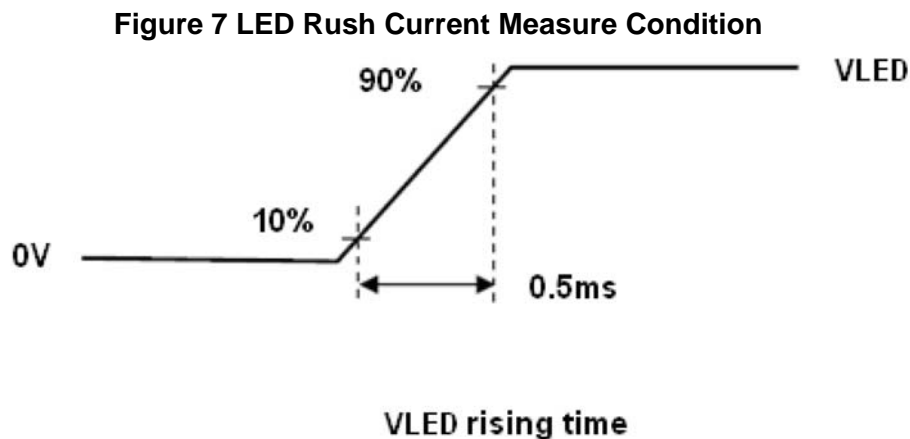

6.0 Electrical Characteristics

6.1 TFT LCD Module Interface Connector

Table 4 Connector Name / Designation

Item	Description
Type / Part Number	MSB24013P20HA

Table 5 Signal Pin Assignment

Pin #	Signal Name	Description	Remarks
1	VDD	Power Supply, 3.3V (typical)	-
2	VDD	Power Supply, 3.3V (typical)	-
3	VSS	GND	-
4	REV	Reverse Scan selection	1*
5	Rin1-	-LVDS differential data input	
6	Rin1+	+LVDS differential data input	
7	VSS	GND	
8	Rin2-	-LVDS differential data input	
9	Rin2+	+LVDS differential data input	
10	VSS	GND	
11	Rin3-	-LVDS differential data input	
12	Rin3+	+LVDS differential data input	
13	VSS	GND	
14	CIKIN-	-LVDS differential data input	
15	CIKIN+	+LVDS differential data input	
16	GND	GND	
17	Rin4-	-LVDS differential data input	
18	Rin4+	+LVDS differential data input	
19	SEL68	6/8 bits LVDS data input selection(H:8bit L/NC:6bit)	
20	Bist	Internal use	

Note1: About REV Please refer ;

Note2: All input signals shall be low or Hi-resistance state when VDD is off.

6.2 TFT Backlight Interface Connector

Table 6 Connector Name / Designation

Item	Description
Type / Part Number	MSB24038P5A

Pin #	Function
1	VCC(12V input)
2	GND
3	On/Off(5V-ON,0V-OFF)
4	Dimming(PWM)
5	NC

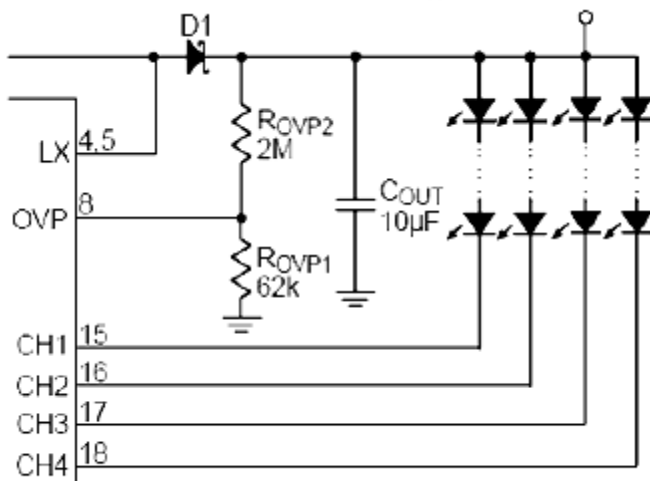

7.0 Interface Timings

7.1 Timing Characteristics

Table 6 Interface Timings

Parameter	Symbol	Unit	Min.	Typ.	Max.
LVDS Clock Frequency	Fclk	MHz	(52)	(65)	(71)
H Total Time	HT	Clocks	(1,114)	(1,344)	(1,400)
H Active Time	HA	Clocks	1,024	1,024	1,024
H Blanking Time	HBL	Clocks	(90)	(320)	(376)
V Total Time	VT	Lines	(778)	(806)	(845)
V Active Time	VA	Lines	768	768	768
V Blanking Time	VBL	Lines	(10)	(38)	(77)
Frame Rate	Vsync	Hz	55	60	65

Synchronization Method: DE only

Note: H Blank area and V Blank area can not be changed at every frame

7.2 Timing Diagram of Interface Signal

Figure 8 Timing Characteristics

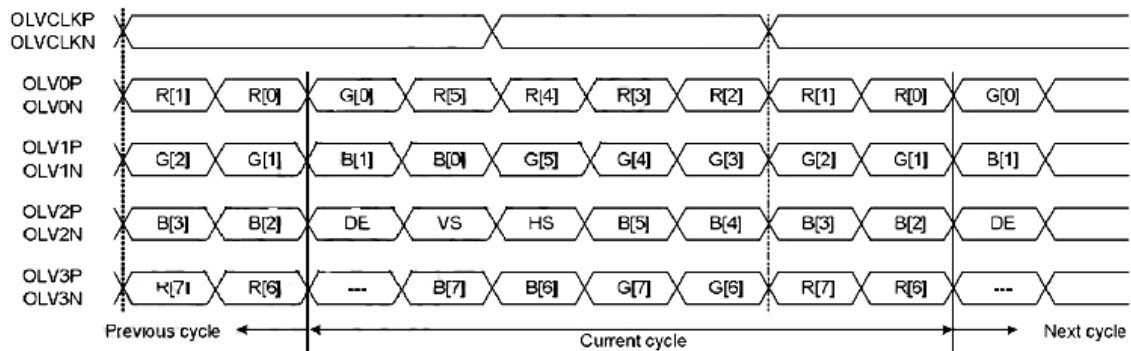

8.0 Power ON/OFF Sequence

VDD power on/off sequence is as follows. Interface signals are also shown in the chart. Signals from any system shall be Hi-Z state or low level when VDD is off.

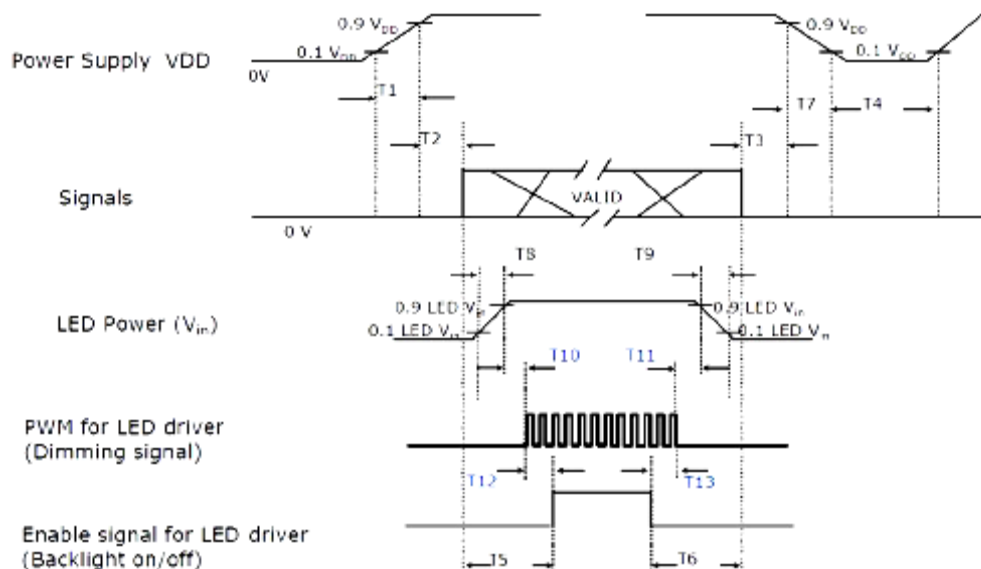

Power ON/OFF Sequence					
Items	Symbol	MIN	TYP	MAX	Unit
VDD rising time from 10% to 90%	T1	0.5	-	10	ms
Delay from VDD to valid data at power ON	T2	30	-	50	ms
Delay from valid data OFF to VDD OFF at power OFF	T3	0	-	50	ms
VDD OFF time for windows restart	T4	500	-	-	ms
Delay from valid data to B/L enable at power ON	T5	200	-	-	ms
Delay from valid data off to B/L disable at power Off	T6	200	-	-	ms
VDD falling time from 90% to 10%	T7	0.5	-	10	ms
LED V _{in} rising time from 10% to 90%	T8	0.5	-	10	ms
LED V _{in} falling time from 90% to 10%	T9	0.5	-	10	ms
Delay from LED driver V _{in} rising time 90% to PWM ON	T10	0	-	-	ms
Delay from PWM Off to LED driver V _{in} falling time 10%, Must keep rule	T11	0	-	-	ms
Delay from PWM ON to B/L Enable ON, Must keep rule	T12	0	-	-	ms
Delay from B/L Enable Off to PWM Off	T13	0	-	-	ms

9 USE PRECAUTIONS

9.1 Handling precautions

- 1) The polarizing plate may break easily so be careful when handling it. Do not touch, press or rub it with a hard-material tool like tweezers.
- 2) Do not touch the polarizing plate surface with bare hands so as not to make it dirty. If the surface or other related part of the polarizing plate is dirty, soak a soft cotton cloth or chamois leather in benzine and wipe off with it. Do not use chemical liquids such as acetone, toluene and isopropyl alcohol. Failure to do so may bring chemical reaction phenomena and deteriorations.
- 3) Remove any spit or water immediately. If it is left for hours, the suffered part may deform or decolorize.
- 4) If the LCD element breaks and any LC stuff leaks, do not suck or lick it. Also if LC stuff is stuck on your skin or clothing, wash thoroughly with soap and water immediately.

9.2 Installing precautions

- 1) The PCB has many ICs that may be damaged easily by static electricity. To prevent breaking by static electricity from the human body and clothing, earth the human body properly using the high resistance and discharge static electricity during the operation. In this case, however, the resistance value should be approx. $1M\Omega$ and the resistance should be placed near the human body rather than the ground surface. When the indoor space is dry, static electricity may occur easily so be careful. We recommend the indoor space should be kept with humidity of 60% or more. When a soldering iron or other similar tool is used for assembly, be sure to earth it.
- 2) When installing the module and ICs, do not bend or twist them. Failure to do so may crack LC element and cause circuit failure.
- 3) To protect LC element, especially polarizing plate, use a transparent protective plate (e.g., acrylic plate, glass etc) for the product case.
- 4) Do not use an adhesive like a both-side adhesive tape to make LCD surface (polarizing plate) and product case stick together. Failure to do so may cause the polarizing plate to peel off.

9.3 Storage precautions

- 1) Avoid a high temperature and humidity area. Keep the temperature between 0°C and 35°C and also the humidity under 60%.
- 2) Choose the dark spaces where the product is not exposed to direct sunlight or fluorescent light.
- 3) Store the products as they are put in the boxes provided from us or in the same conditions as we recommend.

9.4 Operating precautions

- 1) Do not boost the applied drive voltage abnormally. Failure to do so may break ICs. When applying power voltage, check the electrical features beforehand and be careful. Always turn off the power to the LC module controller before removing or inserting the LC module input connector. If the input connector is removed or inserted while the power is turned on, the LC module internal circuit may break.
- 2) The display response may be late if the operating temperature is under the normal standard, and the display may be out of order if it is above the normal standard. But this is not a failure; this will be restored if it is within the normal standard.
- 3) The LCD contrast varies depending on the visual angle, ambient temperature, power voltage etc. Obtain the optimum contrast by adjusting the LC drive voltage.
- 4) When carrying out the test, do not take the module out of the low-temperature space suddenly. Failure to do so will cause the module condensing, leading to malfunctions.
- 5) Make certain that each signal noise level is within the standard (L level: 0.2V_{dd} or less and H level: 0.8V_{dd} or more) even if the module has functioned properly. If it is beyond the standard, the module may often malfunction. In addition, always connect the module when making noise level measurements.
- 6) The CMOS ICs are incorporated in the module and the pull-up and pull-down function is not adopted for the input so avoid putting the input signal open while the power is ON.

- 7) The characteristic of the semiconductor element changes when it is exposed to light emissions, therefore ICs on the LCD may malfunction if they receive light emissions. To prevent these malfunctions, design and assemble ICs so that they are shielded from light emissions.
- 8) Crosstalk occurs because of characteristics of the LCD. In general, crosstalk occurs when the regularized display is maintained. Also, crosstalk is affected by the LC drive voltage. Design the contents of the display, considering crosstalk.

9.5Other

- 1) Do not disassemble or take the LC module into pieces. The LC modules once disassembled or taken into pieces are not the guarantee articles.
- 2) The residual image may exist if the same display pattern is shown for hours. This residual image, however, disappears when another display pattern is shown or the drive is interrupted and left for a while. But this is not a problem on reliability.
- 3) AMIPRE will provide one year warrantee for all products and three months warrantee for all repairing products.

10. MECHANIC DRAWING

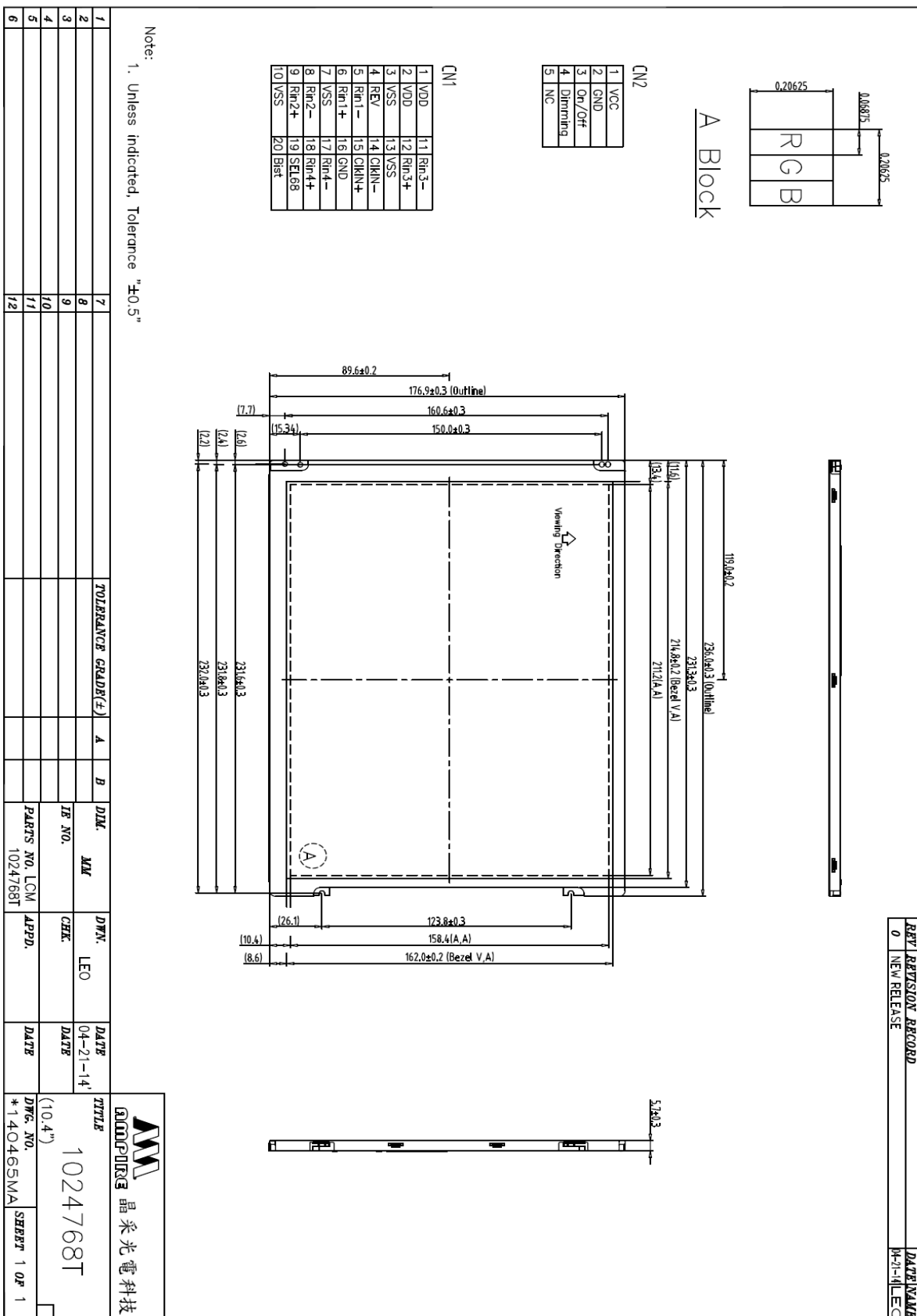

Note:
1. Unless indicated, Tolerance "±0.5"

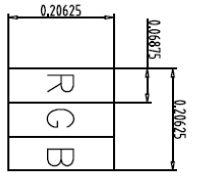

A Block

1	VCC
2	GND
3	On/Off
4	Dimming
5	NC

1	VDD	11	Rin3-
2	VDD	12	Rin3+
3	VSS	13	VSS
4	REV	14	ClKN-
5	Rin1-	15	ClKN+
6	Rin1+	16	GND
7	VSS	17	Rin4-
8	Rin2-	18	Rin4+
9	Rin2+	19	SEL68
10	VSS	20	Brst

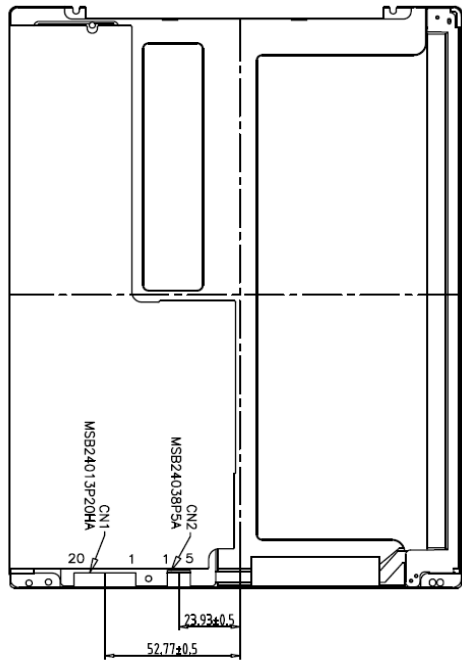

Note:
1. Unless indicated, Tolerance "±0.5"

1		7																	
2		8																	
3		9																	
4		10																	
5		11																	
6		12																	

	晶采光電科技
	AMPIRE
TITLE	1024768T
(10.4")	
DWG. NO.	*140466MA
SHEET	1 OF 1