

**WINSTAR Display**

**OLED SPECIFICATION**

Model No:

**WEO012864J-CTP**

## General Specification

Item	Dimension	Unit
Dot Matrix	128 x 64	—
Module dimension	75.0 x 52.7 x 10.2 MAX	mm
Active Area	55.01 x 27.49	mm
Pixel Size	0.40 x 0.40	mm
Pixel Pitch	0.43 x 0.43	mm
Display Mode	Passive Matrix	
Display Color	Monochrome	
Drive Duty	1/64 Duty	
IC	SSD1309	
Interface	8Bits 6800 , Optional 8080 / 4-SPI / I2C	
Size	2.42 inch	
PCAP IC	GT911	
Detect Point	1	
PCAP Interface	I2C	
Surface	Normal Glare	

# Contour Drawing & Block Diagram

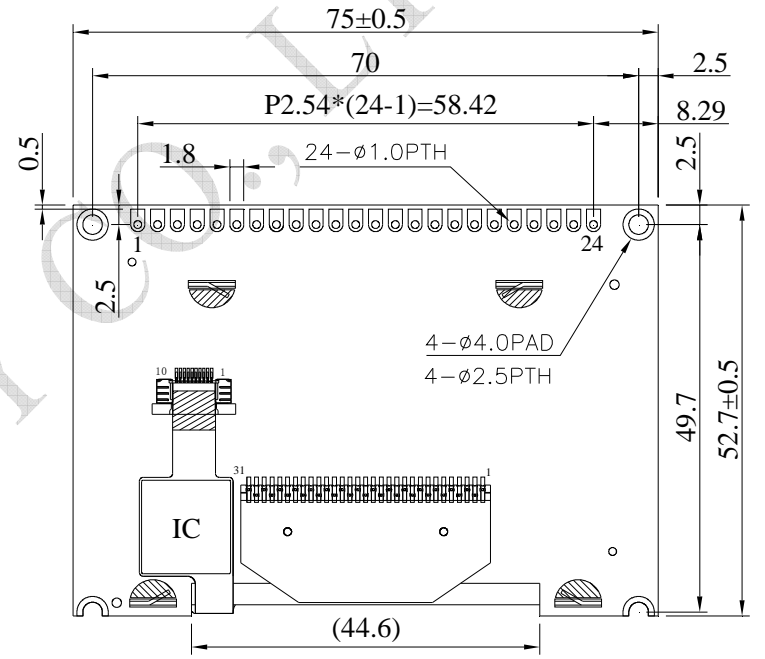
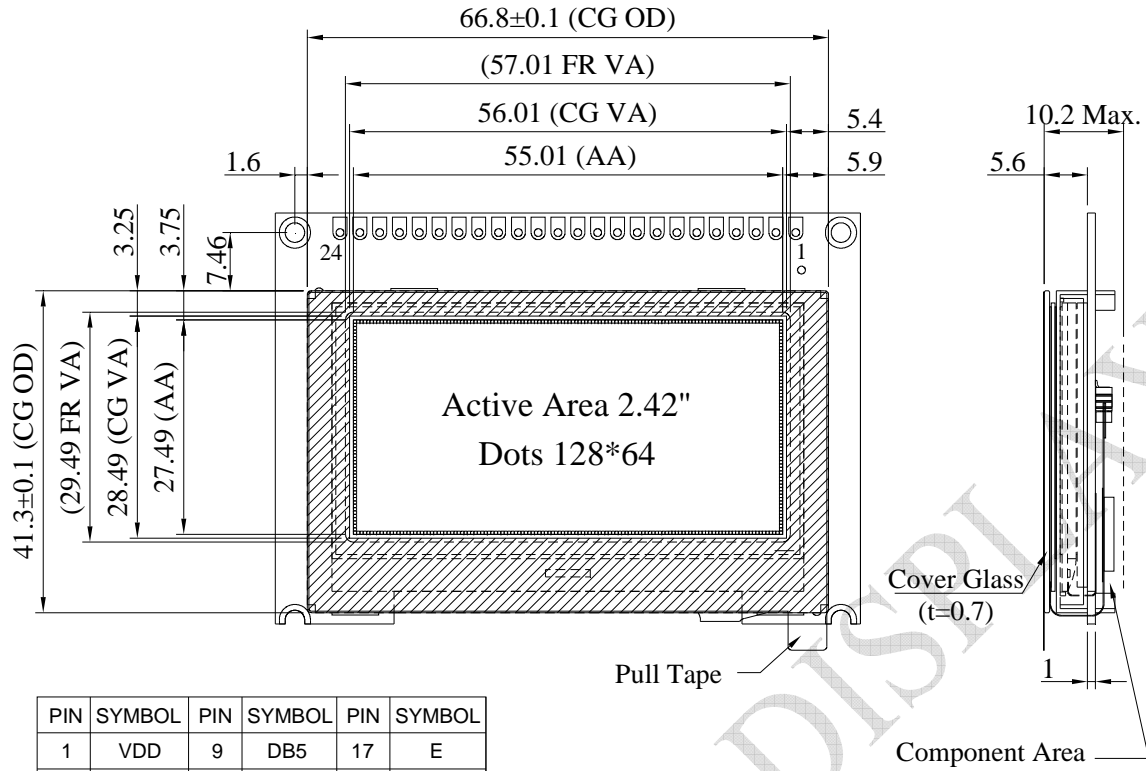

PIN	SYMBOL	PIN	SYMBOL	PIN	SYMBOL
1	VDD	9	DB5	17	E
2	VSS	10	DB6	18	NC
3	NC	11	DB7	19	DISP
4	DB0	12	CS#	20	NC
5	DB1	13	NC	21	TP_INT
6	DB2	14	RES#	22	TP_SDA
7	DB3	15	R/W#	23	TP_SCL
8	DB4	16	D/C#	24	TP_RST

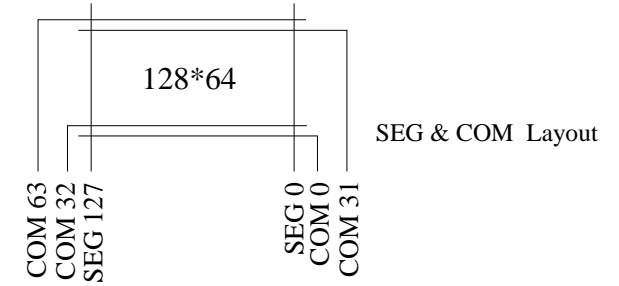
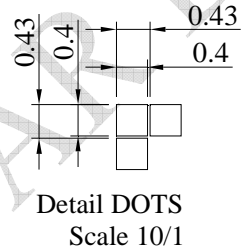

The non-specified tolerance of dimension is ± 0.3mm.

## Interface Pin Function

No.	Symbol	Function
1	VDD	Power supply pin for core logic operation
2	VSS	Ground.
3	NC(GND)	No connection
4~11	D0~D7	These pins are bi-directional data bus connecting to the MCU data bus. Unused pins are recommended to tie LOW.
12	CS#	This pin is the chip select input connecting to the MCU. The chip is enabled for MCU communication only when CS# is pulled LOW (active LOW).
13	NC(GND)	No connection
14	RES#	This pin is reset signal input. When the pin is pulled LOW, initialization of the chip is executed. Keep this pin pull HIGH during normal operation.
15	R/W#	This pin is read / write control input pin connecting to the MCU interface. When 6800 interface mode is selected, this pin will be used as Read/Write (R/W#) selection input. Read mode will be carried out when this pin is pulled HIGH and write mode when LOW.
16	D/C#	This pin is Data/Command control pin connecting to the MCU. When the pin is pulled HIGH, the data at D[7:0] will be interpreted as data. When the pin is pulled LOW, the data at D[7:0] will be transferred to a command register.
17	E	This pin is MCU interface input. When 6800 interface mode is selected, this pin will be used as the Enable (E) signal.
18	NC(GND)	No connection
19	DISP	No Connection
20	NC(GND)	No connection
21	TP_INT	Interrupt signal, active low, asserted to request Host start a new transaction
22	TP_SDA	I2C data signal
23	TP_SCL	I2C clock signal
24	TP_RST	External reset signal, active low

## Absolute Maximum Ratings

Parameter	Symbol	Min	Max	Unit
Supply Voltage for Logic	VDD	-0.3	4	V
Operating Temperature	TOP	-20	+70	°C
Storage Temperature	TSTG	-30	+80	°C

## Electrical Characteristics

### DC Electrical Characteristics

Item	Symbol	Condition	Min	Typ	Max	Unit
Supply Voltage for Logic	VDD	—	2.8	3.0	3.3	V
High Level Input	VIH	—	0.8×VDD	—	—	V
Low Level Input	VIL	—	—	—	0.2×VDD	V
High Level Output	VOH	—	0.9×VDD	—	—	V
Low Level Output	VOL	—	—	—	0.1×VDD	V
50% Check Board operating Current	IDD	VDD =3V	-	150	300	mA